

Model Shown:
X1E1-PT



Features

THE POWER TEAM X1E1-PT: SOLD FOR YEARS TO END CUSTOMERS.

- Base pump unit: Power Team PE55 series – the standard in the industry
- Two-speed high-performance pump
- Retract side internal relief-valve protects tools
- 4-way / 2-position solenoid valve standard
- Utilizes rugged electrical controls
- External adjustable pressure regulator
- Hand remote standard
- For single or double-acting tools



CAUTION

THIS PUMP SHOULD NOT BE USED FOR LIFTING APPLICATIONS, IT'S DESIGN FOR TORQUE WRENCH APPLICATIONS ONLY.

Tools

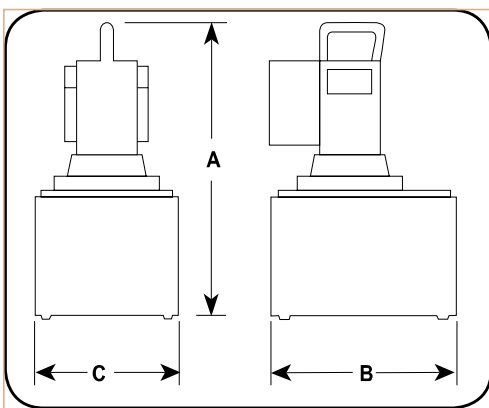

Ordering Information

Order No.	A	B	C	Description	Electric Motor Volt	Oil Delivery per min. (cm ³)	Oil Reservoir Cap. (l)	Prod. Wt. (kg)
	(mm)	(mm)	(mm)					
X1E2-PT	457	330	353	Electric-Powered Torque Wrench Pump	220V	901	9,5	33

Model Shown:
X1A1-PT



Features

X1A1-PT FEATURES THE SAME RUGGED TIME-PROVEN DESIGN AS THE POWER TEAM X1E1-PT.

- Base pump unit, Power Team PA55 series – the standard in the industry
- Two-speed high-performance pump
- Retract side internal relief-valve protects tools
- 4-way / 2-position air valve standard
- External adjustable pressure regulator
- Hand remote standard



CAUTION

THIS PUMP SHOULD NOT BE USED FOR LIFTING APPLICATIONS, IT'S DESIGN FOR TORQUE WRENCH APPLICATIONS ONLY.

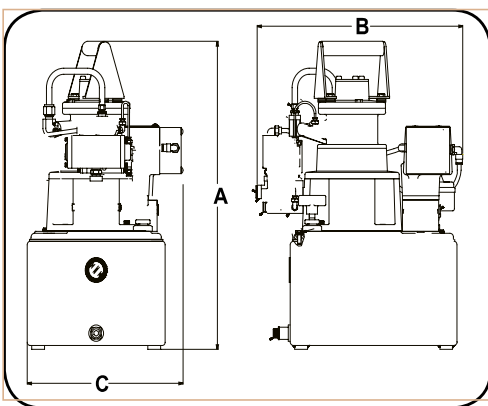

Ordering Information

Order No.	A	B	C	Description	Oil Delivery per min. (cm ³)	Oil Reservoir Cap. (l)	Prod. Wt. (kg)
	(mm)	(mm)	(mm)				
X1A1-PT	477	457	273	Air-Powered Torque Wrench Pump	901	9,5	40