

Model Shown:
J24T, J55T, J106T

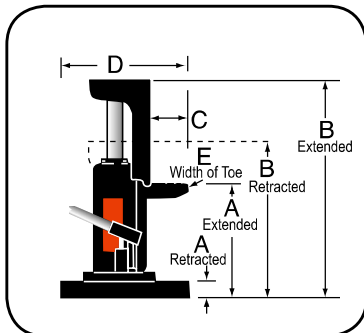

Features

LOW HEIGHT INDUSTRIAL LIFTING AND PUSHING APPLICATIONS.

- These bottle jack-style toe jacks are loaded with many of the same features as our standard bottle jacks, but the toe-lift feature and swiveling pump handle socket make them ideal for machinery lifting and positioning.
- An internal pressure relief provides added safety by limiting the jack's lifting capability to the capacity of the toe.
- Spring return is an added feature on the J55T and J106T jacks.
- Swiveling pump handle assembly available on the 5 and 10 ton models. The swiveling jack assembly allows you to access and pump the unit from numerous positions.
- High strength piston and pump linkage for long life.
- All models include over-travel protection.
- Lever Bar included on all models.
- All jacks meet ASME B30.1 standards and carry the Power Team PowerThon™ Lifetime Warranty.

Jacks

Technical Dimensions

Order Number	Ret.	Ext.	Ret.	Ext.	C (mm)	D L x W (mm)	E (mm)
	A		B				
	(mm)	(mm)	(mm)	(mm)			
J24T	16,0	139,7	235,0	355,6	47,8	283 x 240	50,8
J55T	25,4	149,4	292,1	416,1	47,8	283 x 240	76,2
J106T	31,8	181,1	327,2	476,3	63,5	283 x 240	100,1

Ordering Information

Order Number	Cap. (tons)	Max. Lift Stroke (mm)	Strokes to Ext. Piston (25 mm)	Handle Effort at Max. Load (kg)	Carry Handle	Metric Tons at 700 bar	Prod. Wt. (kg)
J24T	2	121	14	19	Yes	1,8	8,3
J55T	5	121	22	27	Yes	4,5	24,0
J106T	10	146	31	33	Yes	8,1	38,0

Model Shown:
J259T, J1095, J58T



Features

HEAVY-DUTY, LOW HEIGHT INDUSTRIAL LIFTING AND PUSHING APPLICATIONS.

- With lifting points on the toe and on the top, these extremely rugged jacks are ideal for machine lifting, rigging, lift truck service and much more.
- Choose from 5.5 ton, 11 ton, or the 27.5 ton lifting capacity.
- All jacks operate both vertically and horizontally.
- Base, toe and pumping assembly swivel independently, allowing the jack to work in confined areas.
- High strength piston and pump linkage for long life.
- Lever Bar included on all models.
- All jacks meet ASME B30.1 standards and carry the Power Team PowerThon™ Lifetime Warranty.

▶ J58T hydraulic toe jack is the perfect choice for the pallet jack application.

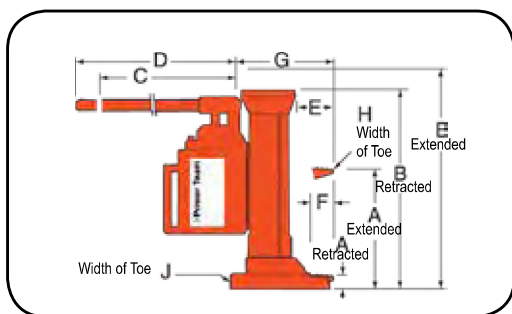

Technical Dimensions

Order Number	Ret.	Ext.	Ret.	Ext.	C	D	E	F	G	H	J
	A		B								
	(mm)	(mm)	(mm)	(mm)							
J58T	30	238	375	584	368	451	71	56	176	41	130
J109T	30	264	419	654	368	451	76	56	183	64	171
J259T	54	289	505	738	210	756	146	102	267	89	270

Ordering Information

Order Number	Cap. (tons)	Max. Lift Stroke (mm)	Strokes to Ext. Piston (25 mm)	Handle Effort at Max. Load (kg)	Carry Handle	Metric Tons at 700 bar	Prod. Wt. (kg)
J58T	5,5	210	8	38	Yes	5,0	19,5
J109T	11,0	235	13	40	Yes	10,0	29,0
J259T	27,5	235	21	40	Yes	24,9	92,1