



# Medium Pressure Products

MPI™ Fittings and Valves  
6,000 – 15,000 PSI Range

Catalog 4234

April 2015

aerospace  
climate control  
electromechanical  
filtration  
fluid & gas handling  
hydraulics  
pneumatics  
process control  
sealing & shielding



ENGINEERING YOUR SUCCESS.

## Table of Contents

Introduction.....	3
Visual Index.....	4
<b>MPI™ Fittings</b>	
Typical Raw Materials.....	8
Tube End Dimension Data.....	8
How To Order .....	8
Tubing Selection Guide .....	9
Temperature Derating Factors.....	9
Maximum Allowable Working Pressure Tables .....	10
MPI™ Tubing.....	10
Cone & Thread Tubing.....	10
Instrumentation Grade Heavy Wall Tubing .....	10
Temperature Derating Factors .....	11
<b>Medium Pressure Fittings</b>	
Medium Pressure Fittings.....	13
<b>Medium Pressure Valves</b>	
MAN Series Valves.....	33
Two Way Inline Valves .....	34
Two Way Angle Valves.....	35
Three Way/Two Pressure Connections .....	36
Three Way/One Pressure Connections.....	36
Three Way/Two Stem Connections .....	37
Two Way Angle Valves (Replacement Seat) .....	37
How to Order MAN Series Valves .....	38
Bleed Valve.....	39
Gauge Valve.....	39
MAB Series Valves.....	40
MAF Series Line Filters.....	52
MACBL Series Check Valves .....	54
MARA Series Relief Valves .....	55
<b>Technical Information</b>	
Assembly Instructions .....	57
Gaugeability Instructions.....	57
Remake Instructions.....	57
Gap Gauge .....	57
Hydraulic Preset Tools.....	58
Offer of Sale .....	63

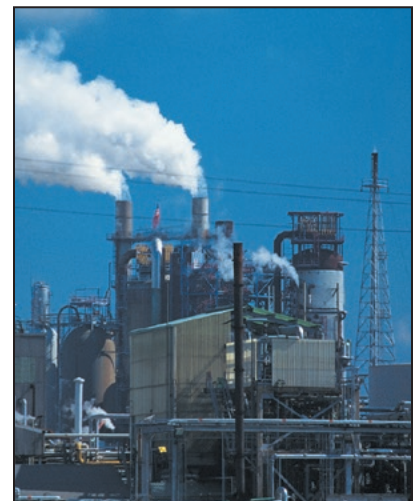
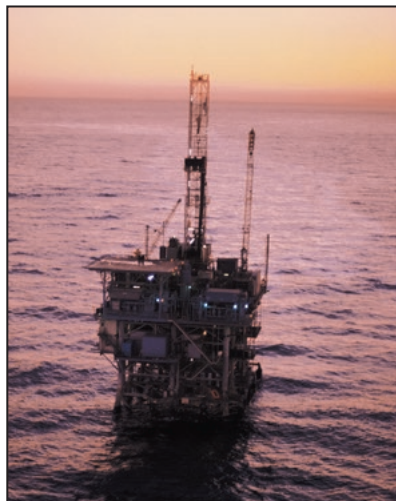

## Introduction

Parker Hannifin MPI™ Fittings are engineered and manufactured to provide secure, tight, and leak-resistant connections throughout industry, including off-shore oil and gas exploration platforms, research labs, and other facilities that require operating pressures in the range of 6,000 to 15,000 psi.

MPI™ Fittings are ideally suited to handle liquids, gases, or chemicals and can be used on a wide variety of tubing materials including cold drawn – 1/8 hard (unannealed) stainless steel tubing, annealed 2507 seamless tubing or instrument grade thick-walled annealed stainless steel. Every Parker MPI™ Fitting is supplied complete and ready to install.

## Advanced Features

Every MPI™ Fitting has the features shown below:

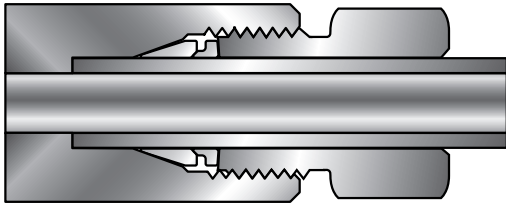

1. Front ferrule with corrosion-resistant Parker Supercase® forms a seal between the tube, body and ferrule. It also provides a mechanical hold on the tube.
2. Back ferrule with corrosion-resistant Parker Supercase® provides a strong mechanical hold on the tube.
3. Longer thread area for improved resistance to pressure and load on the ferrules.
4. Molybdenum disulfide-coated inverted nut helps prevent galling, provides easier assembly, and permits multiple remakes.
5. Long tube-support area improves resistance to vibration and line loads.

## Materials and Identification

Standard MPI™ Fittings are made of Heat Code Traceable 316 stainless steel. Tubing and fitting materials should be selected based on compatibility with the fluid or gas media.

Part numbers for MPI™ Fittings use symbols that identify their style, size, and composition.

## MPI™ Fittings Pressure Ratings

The maximum pressure rating is marked on each fitting. MPI™ working pressures to be determined by selected tubing. Please see tables on page 3 for specific working pressures.

- Size 4 MPI™ – to 15,000 psi
- Size 6 MPI™ – to 15,000 psi
- Size 8 MPI™ – to 15,000 psi
- Size 9 MPI™ – to 15,000 psi
- Size 12 MPI™ – to 15,000 psi
- Size 16 MPI™ – to 12,500 psi

## Assembly

MPI™ Fittings are installed with standard hand tools. Each size can be preset with a Parker hydraulic preset tool. Tube preparation does not require cutting of threads or tube end “coning.”

## Dedication to Quality

Our resources and vast product line are available through our worldwide distribution network. For more information regarding our products and services, please contact your authorized Parker Instrumentation Distributor.



# Visual Index

Visual Index

## MPI™ Fittings



**FBMP7**  
MPI™ Male Connector  
Page 13



**XHBMP7**  
37° Flare to MPI™ Connector  
Page 13



**MP7H2BX**  
37° Flare Bulkhead to MPI™  
Connector  
Page 14



**X41HBMP7**  
High Pressure to MPI™ Connector  
Page 14



**X42HBMP7**  
Medium Pressure to MPI™  
Connector  
Page 15



**GBMP7**  
MPI™ to Female NPT Connector  
Page 15



**MP7HBA**  
MPI™ to SAE Male  
O-ring Connector  
Page 16



**M40HBMP7**  
Type "M" High Pressure  
Hose to MPI™ Connector  
Page 16

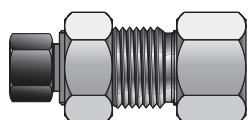

**GH2BMP7**  
MPI™ Bulkhead to Female NPT  
Page 17



**HBMP7**  
MPI™ Union Connector  
Page 17

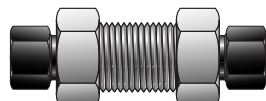

**WBMP7**  
MPI™ Bulkhead Union Connector  
Page 18

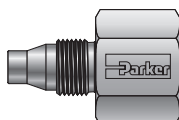

**GM7**  
MPI™ Male End to Female NPT  
Page 18

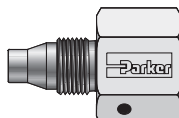

**GM7**  
MPI™ Male End to  
High Pressure C&T Port  
Page 19

## MPI™ Fittings



**T7HBT7**  
MPI™ Tube Port Connector  
Page 19

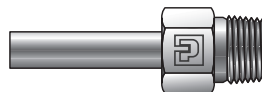

**T7HF**  
MPI™ Tube Stub to Male NPT Pipe  
Page 20



**XHT7**  
37° Flare to MPI™ Tube Stub  
Page 20



**X41HT7**  
High Pressure to MPI™ Tube Stub  
Page 21

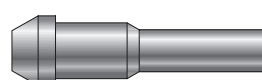

**X47HT7**  
Medium Pressure Port Connector  
to MPI™ Tube Stub  
Page 21



**X42HT7**  
Medium Pressure to MPI™ Tube Stub  
Page 22

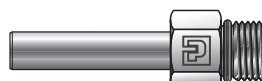

**T7HOA**  
MPI™ Tube Stub to Male SAE O-ring  
Page 22

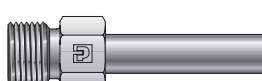

**M40HT7**  
Type "M" High Pressure Hos Adapter  
to MPI™ Tube Stub  
Page 23



**TRBMP7**  
MPI™ Tube Stub Reducer  
Page 23

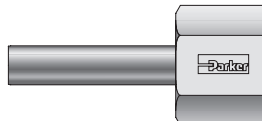

**T7HG**  
MPI™ Tube Stub to  
Female NPT Pipe  
Page 24



**MP7PC**  
MPI™ Port Connector  
Page 24



**NBMP7**  
45° MPI™ Union Elbow  
Page 25

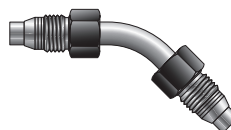

**T7NBT7**  
45° MPI™ Tube Stub Elbow  
Page 25



**EBMP7**  
MPI™ Union Elbow  
Page 26



## Visual Index

### MPI™ Fittings

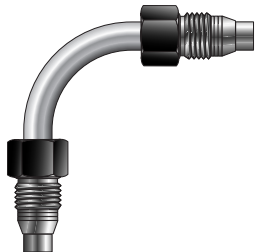

**T7EBT7**  
MPI™ Tube Elbow  
Page 26

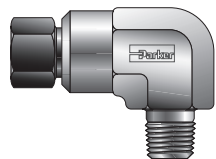

**CBMP7**  
MPI™ to Male NPT Elbow  
Page 27



**JBMP7**  
MPI™ Union Tee  
Page 27



**X44HBMP7**  
X44 Male by MPI™ Connector  
Page 28

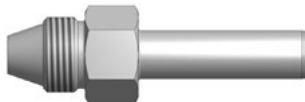

**X44HT7**  
X44 Male by MPI™ Tube Stub  
Page 28



**M40HX44**  
Type "M" Male by X44 Male  
Page 28

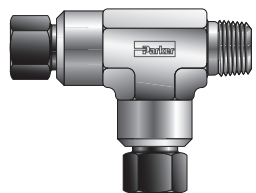

**RBMP7**  
MPI™ to NPT Male Run Tee  
Page 29

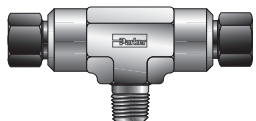

**SBMP7**  
MPI™ to NPT Male Branch Tee  
Page 29



**OBMP7**  
MPI™ to NPT Female Branch Tee  
Page 30

### MPI™ Fittings

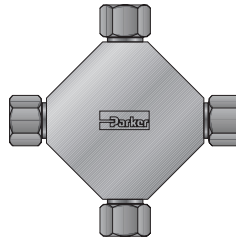

**KBMP7**  
MPI™ Union Cross  
Page 30

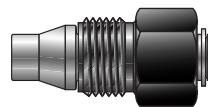

**FNMP7**  
MPI™ Plug  
Page 31



**PNBMP7**  
MPI™ Cap  
Page 31

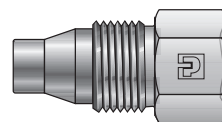

**FNM7**  
MPI™ Plug  
Page 31

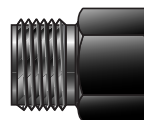

**BMP7**  
MPI™ Nut  
Page 32



**MPFF**  
MPI™ Front Ferrule  
Page 32



**MPBF**  
MPI™ Back Ferrule  
Page 32

# Visual Index

Visual Index

## Medium Pressure Valves

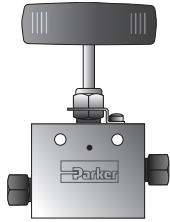

**Two Way Inline Valves**  
Page 34

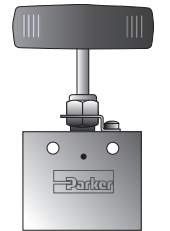

**Two Way Inline Valves**  
Female NPT  
Page 34

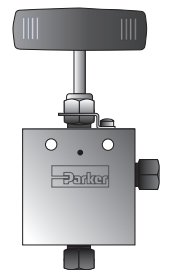

**Two Way Angle Valves**  
Page 35

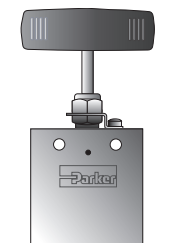

**Two Way Angle Valves**  
Female NPT  
Page 35

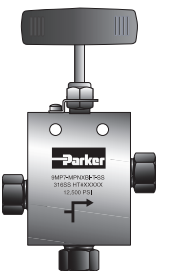

**Three Way/Two Pressure Connection**  
Page 36

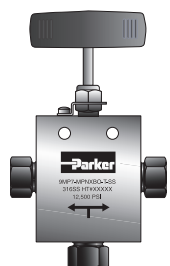

**Three Way/One Pressure Connection**  
Page 36

## Medium Pressure Valves

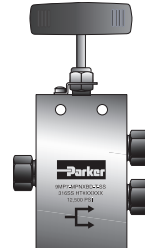

**Three Way/Two Stem Connection**  
Page 37

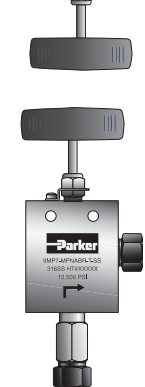

**Two Way Angle Valves**  
(Replacement Seat) Page 37

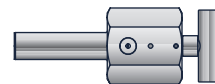

**Medium Pressure Bleed Valve**  
Page 39

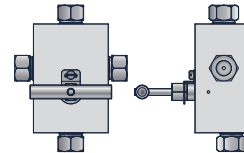

**Medium Pressure Gauge Valve**  
Page 39

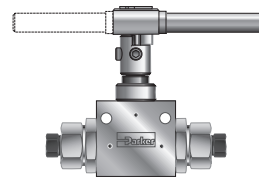

**Two Way Ball Valves**  
Page 40

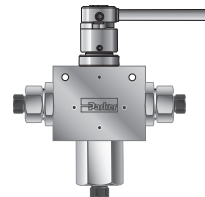

**Three Way Ball Valves**  
Page 42



**Ball Valve MAB Series Actuators**  
Page 45

## Visual Index

### Medium Pressure Valves

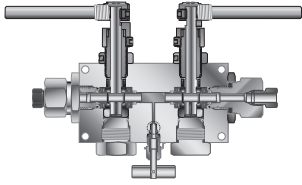

**Double Block & Bleed Ball Valve**  
Page 49

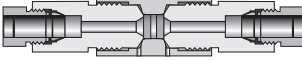

**Dual Disc Line Filter**  
Page 52

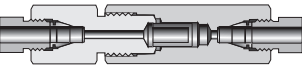

**Cup Line Filter**  
Page 53

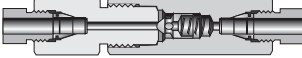

**Check Valves**  
Page 54

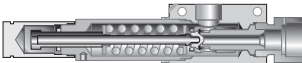

**Hard Seat Relief Valve**  
Page 55

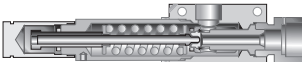

**Soft Seat Relief Valve**  
Page 56

### Technical Information



**Gap Gauge**  
Page 57

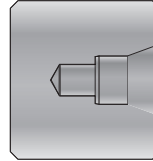

**Hydraulic Preset Tools**  
316SS Tubing  
Page 58

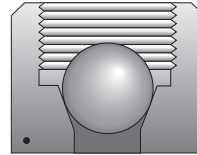

**Port Dimensions**  
Parker X44 Adapter  
Page 60

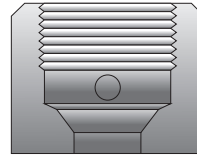

**Port Dimensions**  
Parker X42 Adapter  
Page 61

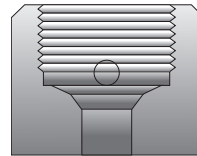

**Port Dimensions**  
Parker X41 Adapter  
Page 62

Visual Index

## Typical Raw Materials

Basic Fitting Material	Bar Stock	Forging
Stainless Steel (Type 316)	ASME/ASTM SA/A-479 Type 316-SS ASTM A-276 Type 316 BS970 316-S31 DIN 4401	ASME SA-182 316 BS970 316-S31 DIN 4401
Super Duplex (2507)	UNS S32750 ASTM A-479	

If additional information, including heat code traceability, is required, contact Parker Hannifin or your nearest MPI™ Fitting distributor.

## Tube End Dimensional Data

Size No.	Inches						
	Tube O.D.	Straight Thread	C	D	E	*L	W Hex
4	1/4	1/2 - 20	.50	1.34	.13	1.62	9/16
6	3/8	5/8 - 20	.63	1.58	.25	1.88	11/16
8	1/2	13/16 - 20	.69	1.85	.31	2.25	15/16
9	9/16	7/8 - 20	.75	1.91	.38	2.25	1
10	5/8	15/16-20	.75	2.02	.44	2.43	1 1/16
12	3/4	1 1/8 - 18	.88	2.26	.52	2.75	1 1/4
16	1	1 7/16 - 18	1.13	2.88	.69	3.38	1 1/2

\*L - Recommended Straight Length of Circular Un-bent Tubing

Dimensions in inches are for reference only, subject to change.

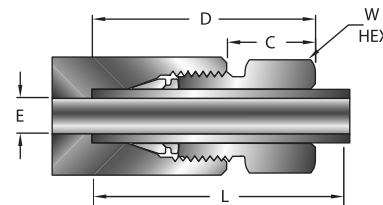

## How To Order MPI™ Fittings

Dimensions in inches are for reference only, subject to change.

Parker MPI™ Fittings should be ordered using the part number as listed in this catalog.

Part numbers are developed as follows:

1. A combination of letters and numbers identifies the size and style of the fitting and the material used.
2. Tube and pipe thread sizes are designated by the number of sixteenths of an inch (1/4" tube = 4/16" or 4).

All standard MPI™ Fittings are manufactured from 316 stainless steel. Other materials are available upon special order.

**Straights and Elbows:** Specify the largest end of the MPI first, followed by the smaller tube end OR pipe thread size.

### Example:

Part number **4-4 HBMP7** union would have the specifications listed below.



4	4	H	B	MP7	SS
1/4" Tube	1/4" Tube	Shape Designator, Union	Assembled with Nut and Ferrules	Medium Pressure Inverted	Stainless Steel

### Tees:

#### Example:

Part number **9-6-6 JBMP7** union would have the specifications listed below.

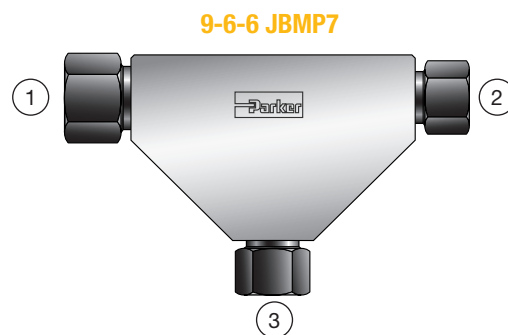

9	6	6	J	B	MP7	SS
9/16" Tube (1)	3/8" Tube (2)	3/8" Tube (3)	Shape Designate, Union Tee	Assembled with Nut and Ferrules	Medium Pressure Inverted	Stainless Steel

**Customer Requests:** When special configurations are required, please provide a blueprint of the installation to Parker with your request for a price quote.

**Cryogenic Service:** MPI™ fittings for cryogenic applications include a vent hole to prevent pressure build-up in front of the threads. To order "vented" MPI™ parts, add "-VT" to the end of the standard part number (e.g., 6-6 HBMP7-SS becomes 6-6 HBMP7-SS-VT).



## Tubing Selection Guide

Although Parker’s MPI™ Fittings are engineered and manufactured to consistently provide high levels of reliability, no system’s integrity is complete without considering the critical link: tubing.

This section is intended to help you properly select and order quality tubing, both annealed and medium-pressure cold drawn – 1/8 hard (unannealed).

Parker believes that proper tubing selection and installation are key to building leak-free, reliable tubing systems.

Parker’s MPI™ Fittings have been designed to operate on a wide variety of “medium pressure” applications (6,000 to 15,000 psi).

## General Selection Criteria

The data tables in this section will help you select the tubing that best satisfies the needs of the application.

The most important consideration in the selection of suitable tubing for any application is the compatibility of the tubing materials with the media to be contained.

## System Pressure

The system operating pressure is another important factor in determining the type, and more importantly, the size of tubing to be used. In general, high pressure installations require strong materials such as stainless steel. Tube fitting assemblies should never be pressurized beyond the recommended working pressure.

## Temperature Derating Factors

Table 1 indicates derating factors for 316 stainless steel tubing and MPI™ fittings at elevated temperatures.

Table 1		Temperature Derating Factors (316 or 317 Stainless Steel Tubing)									
	°F	-425 to 100	200	300	400	500	600	700	800	900	1000
	°C	-254 to 38	93	149	204	260	316	371	427	482	538
<b>1/8 Hard*</b>		1.000	1.000	1.000	0.960	0.885	0.835	0.795	0.770	0.750	0.740
<b>Annealed**</b>		1.000	1.000	1.000	0.965	0.895	0.850	0.815	0.795	0.775	0.765

\* Use with 1/8 Hard 316 tubing shown in Tables 2 (MPI) and 3 (C&T) on page 10.

\*\* Use with Annealed 316 tubing shown in Table 4 on page 10.

The rating at temperature is the room temperature (RT) pressure rating listed in the catalog multiplied by the Derating Factor at temperature.

**Example:** 1/4" MPI™ fittings and tubing @ 800°F

Room Temperature Working Pressure  
= **15,000** psi (as shown in Table 2)

800°F Temperature Derating Factor  
= **.770** (1/8 Hard tube) (as shown above)

<b>800°F Working Pressure</b> <b>= 15,000 x .770 = 11,550 psi</b>	
--	--

## Maximum Allowable Working Pressure Tables

Tables 2, 3, 4 and 7 list the maximum suggested working pressure of various tubing sizes, according to material. Acceptable tubing diameters and wall thicknesses are those for which a rating is listed. Combinations which do not have a pressure rating are not recommended for use with MPI™ Fittings.

### MPI™ Tubing

MPI™ tubing is marked "MPI" and is designed to provide optimum performance for MPI™ fittings. MPI™ tubing is nominal OD ± .003" 316 seamless stainless steel, cold drawn – 1/8 hard (unannealed) tubing. Tensile strength is approximately 40% higher than annealed tubing.

**Table 2 – 316 or 317 Stainless Steel (Seamless / Unannealed – 1/8 Hard)**

Tube Size (in.)	Nominal OD (in.)	Nominal ID (in.)	Working Pressure (psi)	MPI™ Tube Part No.*
1/4	.250	.125	15,000	4-240 MPITube-SS-15K
3/8	.375	.219	15,000	6-240 MPITube-SS-15K
9/16	.562	.344	15,000	9-240 MPITube-SS-15K
3/4	.750	.469	15,000	12-240 MPITube-SS-15K
1	1.000	.656	12,500	16-240 MPITube-SS-12K

**NOTE:** Working pressures calculated using an allowable stress of 35,000 psi for 1/8 hard 316 stainless steel tubing with a minimum tensile strength of 105,000 psi.

**NOTE:** Sizes 3/4" & 1" require hydraulic presetting when used with MPI™ fittings.

**\*Consult factory for pressure tables regarding other materials.**

Dimensions in inches are for reference only, subject to change.

\* To order 317 tube replace SS with 317

### Cone & Thread Tubing

Cone & Thread (C&T) tubing is available as 1/8 hard 316 seamless stainless steel tubing and is designed to work with existing C&T fittings. C&T tubing has an undersized OD by as much as .010" to better facilitate the coning and threading operations required for use with C&T fittings. MPI™ fittings work effectively with C&T tubing as listed below but **require hydraulic presetting** for optimum performance.

**Table 3 – 316 Stainless Steel (Undersized OD, Seamless / Unannealed – 1/8 Hard)**

Tube Size (in.)	Maximum OD (in.)	Nominal ID (in.)	Working Pressure (psi)	Parker Autoclave Part Number
1/4	.250	.109	12,500	15-092
3/8	.375	.203	12,500	15-093
9/16	.562	.312	12,500	15-085
9/16	.562	.359	10,000	15-097
3/4	.750	.516	10,000	15-098
1	1.000	.688	10,000	15-099

### Instrumentation Grade Heavy Wall Tubing

**Table 4 – 316 or 317 Stainless Steel (Seamless / Annealed)**

Tube Size (in.)	Tube Wall Thickness (in.)								
	.065	.083	.095	.109	.120	.134	.156	.188	.220
Working Pressure (psi)									
1/4	10,300	13,300							
3/8	6,600	8,600	10,000	11,700					
1/2		6,700	7,800	9,100	10,000	11,400			
3/4				5,800	6,400	7,300	8,600	10,600	
1					4,700	5,300	6,200	7,700	9,200

**NOTE:** Working pressures calculated using an allowable stress of 20,000 psi for annealed 316 stainless steel tubing with a nominal O.D. tolerance of ± .005".

Dimensions in inches are for reference only, subject to change.

## Tubing Selection Guide

Although Parker's MPI™ Fittings are engineered and manufactured to consistently provide high levels of reliability, no system's integrity is complete without considering the critical link: tubing.

This section is intended to help you properly select and order quality tubing, both annealed and medium-pressure cold drawn – 1/8 hard (unannealed).

Parker believes that proper tubing selection and installation are key to building leak-free, reliable tubing systems.

Parker's MPI™ Fittings have been designed to operate on a wide variety of "medium pressure" applications (6,000 to 15,000 psi).

## General Selection Criteria

The data tables in this section will help you select the tubing that best satisfies the needs of the application.

The most important consideration in the selection of suitable tubing for any application is the compatibility of the tubing materials with the media to be contained.

## System Pressure

The system operating pressure is another important factor in determining the type, and more importantly, the size of tubing to be used. In general, high pressure installations require strong materials such as stainless steel. Tube fitting assemblies should never be pressurized beyond the recommended working pressure.

## Temperature Derating Factors

Table 5 indicates derating factors for 2507 tubing and MPI™ fittings at elevated temperatures.

Table 5		Temperature Derating Factors (2507 Tubing)					
	Temperature	°F	100	200	300	400	500
	Derating	Factor	1	0.9	0.86	0.82	0.81

Note: Use with Annealed 2507 tubing shown in Table 7 on Page 12

The rating at temperature is the room temperature (RT) pressure rating listed in the catalog multiplied by the Derating Factor at temperature.

**Example:** 1/4" x .049 2507 tubing with MPI™ fittings @ 400°F

Room Temperature Working Pressure  
= **15,000** psi (as shown in Table 7)

400°F Temperature Derating Factor  
= **0.82** (2507 tube) (as shown above)

**400°F Working Pressure**  
= 15,000 x .82 = 12,300 psi

MPI™ Fittings



## MPI™ Tubing

**Table 6 – MPI™ 2507 Seamless Tubing** <sup>1</sup>

Tubing is an engineered part of our total system “package” - the same as any of our components. Parker’s 2507 MPI™ tubing is manufactured to a specialized and tightly controlled set of design specifications that make it different than that of standard “commercial” tubing. We have designed our products (Valves, Fittings, & Tubing) to work together as a complete system. Using Parker’s MPI™ 2507 tubing in your system will gain you the following benefits:

- **Minimum PREN of 42**  
Offers an increased chloride corrosion resistance over standard ASTM A789 tube (PREN 38).
- **6% Greater Allowable Stress<sup>2</sup>**  
Allows the tube wall to be thinner without compromising pressure holding capability.
- **Up to 19% Weight Saving**  
Critical in offshore application where every pound counts.<sup>3</sup>
- **Optimized ID (inner diameter) with up to 43% Flow Area Increase<sup>2</sup>**  
Parker has maximized flow area and minimized pressure drop which allows for more consistent fluid dynamic calculations.<sup>3</sup>
- **Finite Tight Tolerance Tube<sup>2</sup>**  
Unlike standard ASTM A789 tubing where tolerance is based on percentage of wall thickness, Parker’s MPI™ tubing offers a tolerance of ±0.003 regardless of size, for dimensional consistency from lot to lot.

Tube Size (in.)	Nominal OD (in.)	Nominal ID (in.)	Working Pressure (psi)	MPI™ Tube Part No.
1/4	0.250	0.152	15,000	4-240 MPITUBE-2507-15K
3/8	0.375	0.250	15,000	6-240 MPITUBE-2507-15K
1/2	0.500	0.334	15,000	8-240 MPITUBE-2507-15K
3/4	0.750	0.500	15,000	12-240 MPITUBE-2507-15K
1	1.000	0.772	15,000	16-240 MPITUBE-2507-15K

**NOTE:** Working Pressures calculated using an allowable stress of 41,000 psi for annealed 2507 super duplex tubing with a minimum tensile strength of 123,000 psi.

**NOTE:** Sizes 3/4" & 1" require hydraulic presetting when used with MPI™ fittings.

**Consult factory for pressure tables regarding other materials.**

Dimensions in inches are for reference only, subject to change.

<sup>1</sup> Customer should verify acceptable corrosion resistance for the combination of 316 fittings with 2507 tubing for their specific application (media and environment).

<sup>2</sup> When compared to standard ASTM A789 tubing

<sup>3</sup> Based on 3/8 x 0.083" tubing

## Nominal Wall 2507 Tubing

**Table 7 – MPI™ Fittings on Annealed 2507 Seamless Tubing** <sup>1,2,3</sup>

Tube Size (in.)	Wall Thickness								
	0.035	0.049	0.065	0.083	0.095	0.109	0.120	0.134	0.156 <sup>4</sup>
Working Pressure (psi)									
1/4	10,600	15,000							
3/8	6,800	9,900	13,600 <sup>4</sup>	15,000 <sup>4</sup>					
1/2		7,200	9,900	13,000 <sup>4</sup>	15,000 <sup>4</sup>				
5/8			7,700	10,100 <sup>4</sup>	11,800 <sup>4</sup>	13,700 <sup>4</sup>	15,000 <sup>4</sup>		
3/4			6,400	8,300	9,600 <sup>4</sup>	11,200 <sup>4</sup>	12,500 <sup>4</sup>	14,100 <sup>4,5</sup>	
1				6,100	7,000	8,200 <sup>4</sup>	9,100 <sup>4</sup>	10,200 <sup>4</sup>	12,100 <sup>4</sup>

<sup>1</sup> Customer should verify acceptable corrosion resistance for the combination of 316 fittings with 2507 tubing for their specific application (media and environment).

<sup>2</sup> Tubing per ASTM A789 for UNS S32750 material is recommended.

<sup>3</sup> ASME B31.3 allowable stress of 38,700 psi for UNS 32750 (A789) and tube wall thickness tolerance of ±10% used to calculate pressure ratings. Please contact factory for assistance in calculating pressure ratings for different parameters.

<sup>4</sup> Heavier wall 2507 (high lighted fields) may require additional preset pressure. Refer to page 59 for recommended 2507 tube preset pressures.

<sup>5</sup> 15,000 psi with a minimum wall thickness of 0.127"

<sup>6</sup> Size 10 MPI is only available for 2507 tube applications.

## FBMP7

MPI™ to Male NPT Connector

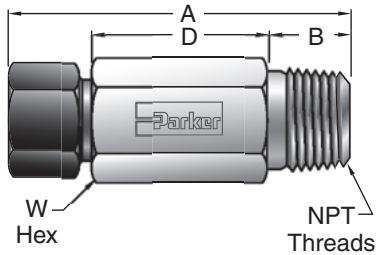

Parker Part No.	Inches						Working Pressure (PSIG)
	MPI™ Size	NPT Thread	A	B	D	W Hex	
4-2 FBMP7	1/4	1/8 - 27	1.91	.38	1.03	5/8	15,000
4-4 FBMP7	1/4	1/4 - 18	2.10	.57	1.03	5/8	15,000
4-6 FBMP7	1/4	3/8 - 18	2.00	.57	.93	3/4	15,000
4-8 FBMP7	1/4	1/2 - 14	2.17	.76	.91	7/8	15,000
6-4 FBMP7	3/8	1/4 - 18	2.43	.57	1.24	3/4	15,000
6-6 FBMP7	3/8	3/8 - 18	2.43	.57	1.24	3/4	15,000
6-8 FBMP7	3/8	1/2 - 14	2.48	.76	1.10	7/8	15,000
8-6 FBMP7	1/2	3/8 - 18	2.85	.57	1.60	1	15,000
8-8 FBMP7	1/2	1/2 - 14	2.81	.76	1.37	1	15,000
9-6 FBMP7	9/16	3/8 - 18	2.91	.57	1.59	1-1/16	15,000
9-8 FBMP7	9/16	1/2 - 14	3.04	.76	1.53	1-1/16	15,000
10-8 FBMP7	5/8	1/2 - 14	3.03	.76	1.52	1-3/16	15,000
12-8 FBMP7	3/4	1/2 - 14	3.85	.76	2.21	1-3/8	15,000
12-12 FBMP7	3/4	3/4 - 14	3.46	.76	1.82	1-3/8	10,000
16-12 FBMP7	1	3/4 - 14	4.53	.76	2.64	1-3/4	10,000
16-16 FBMP7	1	1 - 11.5	4.58	.95	2.50	1-3/4	10,000

Dimensions in inches are for reference only, subject to change.

## XHBMP7

37° Flare to MPI™ Connector

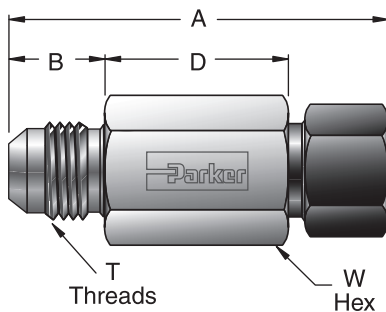

Parker Part No.	Inches							Working Pressure (PSIG)
	37° Flare Adapter	MPI™ Size	A	B	D	T Thread	W Hex	
4-4 XHBMP7	1/4	1/4	2.08	.55	1.03	7/16 - 20	5/8	15,000
4-6 XHBMP7	1/4	3/8	2.54	.55	1.37	7/16 - 20	3/4	15,000
4-8 XHBMP7	1/4	1/2	2.90	.55	1.66	7/16 - 20	1	15,000
4-9 XHBMP7	1/4	9/16	2.96	.55	1.66	7/16 - 20	1-1/16	15,000
4-10 XHBMP7	1/4	5/8	3.14	.55	1.84	7/16 - 20	1-3/16	15,000
6-4 XHBMP7	3/8	1/4	1.97	.56	.92	9/16 - 18	5/8	12,500
6-6 XHBMP7	3/8	3/8	2.24	.56	1.06	9/16 - 18	3/4	12,500
6-8 XHBMP7	3/8	1/2	2.90	.56	1.66	9/16 - 18	1	12,500
6-9 XHBMP7	3/8	9/16	2.97	.56	1.66	9/16 - 18	1-1/16	12,500
8-6 XHBMP7	1/2	3/8	2.34	.66	1.06	3/4 - 16	3/16	12,500
8-8 XHBMP7	1/2	1/2	2.69	.66	1.34	3/4 - 16	1	12,500
8-9 XHBMP7	1/2	9/16	2.77	.66	1.36	3/4 - 16	1-1/16	12,500
8-10 XHBMP7	1/2	5/8	3.13	.66	1.72	3/4 - 16	1-3/16	12,500
8-12 XHBMP7	1/2	3/4	3.38	.86	1.63	1-1/16 - 12	1-3/8	12,500
16-16 XHBMP7	1	1	4.23	.91	2.19	1-5/16 - 12	1-3/4	7,200

Dimensions in inches are for reference only, subject to change.

MPI™ Fittings



# MPI™ Medium Pressure Products

## MP7H2BX

37° Flare Bulkhead to MPI™ Connector

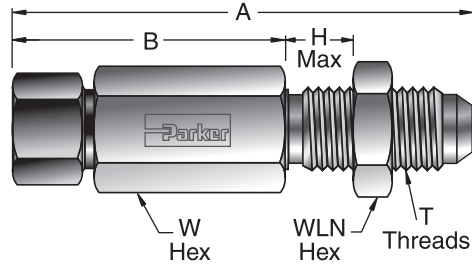

Parker Part No.	Inches								Working Pressure (PSIG)
	37° Flare Adapter	MPI™ Size	A	C	H Max.	T Thread	WLN Hex	W Hex	
4-4 MP7H2BX	1/4	1/4	2.76	1.53	.40	7/16 - 20	11/16	5/8	15,000
6-6 MP7H2BX	3/8	3/8	3.24	1.93	.48	9/16 - 18	13/16	3/4	12,500
8-8 MP7H2BX	1/2	1/2	3.44	1.97	.50	3/4 - 16	1	1	12,500
9-8 MP7H2BX	1/2	9/16	3.76	2.29	.50	3/4 - 16	1	1-1/16	12,500

\* Bulkhead hole approximately 1/64" (.015") larger than thread major diameter.  
Dimensions in inches are for reference only, subject to change.

MPI™ Fittings

## X41HBMP7

High Pressure to MPI™ Connector

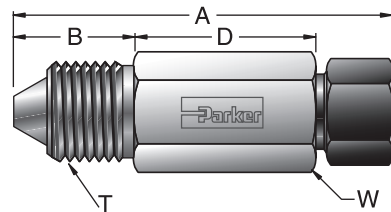

Parker Part No.	Inches							Working Pressure (PSIG)
	High Pressure Adapter	MPI™ Size	A	B	D.	T Thread	W Hex	
4-4 X41HBMP7	1/4	1/4	2.25	.72	1.03	9/16 - 18	5/8	15,000
4-6 X41HBMP7	1/4	3/8	2.71	.72	1.37	9/16 - 18	3/4	15,000
6-4 X41HBMP7	3/8	1/4	2.52	.92	1.10	3/4 - 16	13/16	15,000
6-6 X41HBMP7	3/8	3/8	2.92	.92	1.37	3/4 - 16	13/16	15,000
6-9 X41HBMP7	3/8	9/16	3.37	.92	1.70	3/4 - 16	1-1/16	15,000
9-6 X41HBMP7	9/16	3/8	3.12	1.13	1.37	1-1/8 - 12	1-3/16	15,000
9-9 X41HBMP7	9/16	9/16	3.58	1.13	1.70	1-1/8 - 12	1-3/16	15,000
9-10 X41HBMP7	9/16	5/8	3.69	1.13	1.81	1-1/8 - 12	1-3/16	15,000
9-12 X41HBMP7	9/16	3/4	4.03	1.13	2.02	1-1/8 - 12	1-3/8	15,000

Dimensions in inches are for reference only, subject to change.



## X42HBMP7

Medium Pressure to  
MPI™ Connector

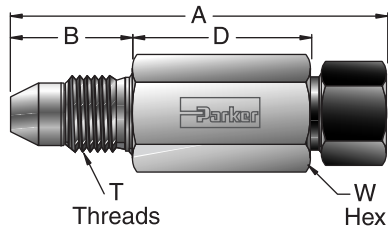

Parker Part No.	Inches						Working Pressure (PSIG)	
	Medium Pressure Adapter	MPI™ Size	A	B	D	T Thread		W Hex
4-4 X42HBMP7	1/4	1/4	2.34	.81	1.03	7/16 - 20	5/8	15,000
4-6 X42HBMP7	1/4	3/8	2.80	.81	1.37	7/16 - 20	3/4	15,000
4-9 X42HBMP7	1/4	9/16	3.31	.81	1.75	7/16 - 20	1-1/16	15,000
6-4 X42HBMP7	3/8	1/4	2.47	.94	1.03	9/16 - 18	3/4	15,000
6-6 X42HBMP7	3/8	3/8	2.93	.94	1.37	9/16 - 18	3/4	15,000
6-8 X42HBMP7	3/8	1/2	3.28	.94	1.65	9/16 - 18	1	15,000
6-9 X42HBMP7	3/8	9/16	3.44	.94	1.75	9/16 - 18	1-1/16	15,000
9-4 X42HBMP7	9/16	1/4	2.56	1.13	.93	13/16 - 16	7/8	15,000
9-6 X42HBMP7	9/16	3/8	2.85	1.13	1.10	13/16 - 16	7/8	15,000
9-8 X42HBMP7	9/16	1/2	3.16	1.13	1.35	13/16 - 16	1	15,000
9-9 X42HBMP7	9/16	9/16	3.41	1.13	1.54	13/16 - 16	1-1/16	15,000
9-10 X42HBMP7	9/16	5/8	3.54	1.13	1.66	13/16 - 16	1-3/16	15,000
9-12 X42HBMP7	9/16	3/4	4.20	1.13	2.19	13/16 - 16	1-3/8	15,000
12-9 X42HBMP7	3/4	9/16	3.55	1.31	1.35	3/4 - 14 NPS	1-1/16	15,000
12-12 X42HBMP7	3/4	3/4	4.15	1.31	1.96	3/4 - 14 NPS	1-3/8	15,000
12-16 X42HBMP7	3/4	1	5.27	1.31	2.83	3/4 - 14 NPS	1-3/4	12,500

Dimensions in inches are for reference only, subject to change.

## GBMP7

MPI™ Female  
NPT Connector

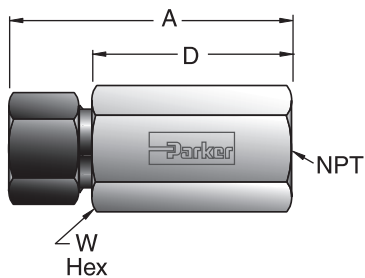

Parker Part No.	Inches					Working Pressure (PSIG)
	MPI™ Size	NPT Thread	A	D	W Hex	
4-2 GBMP7	1/4	1/8 - 27	2.06	1.56	13/16	15,000
4-4 GBMP7	1/4	1/4 - 18	2.25	1.75	1	15,000
4-6 GBMP7	1/4	3/8 - 18	2.35	1.85	1-1/8	15,000
4-8 GBMP7	1/4	1/2 - 14	2.58	2.08	1-3/8	15,000
6-2 GBMP7	3/8	1/8 - 27	2.37	1.74	13/16	15,000
6-4 GBMP7	3/8	1/4 - 18	2.56	1.93	1	15,000
6-6 GBMP7	3/8	3/8 - 18	2.66	2.03	1-1/8	15,000
6-8 GBMP7	3/8	1/2 - 14	2.87	2.24	1-3/8	15,000
8-4 GBMP7	1/2	1/4 - 18	2.89	2.20	1	15,000
8-6 GBMP7	1/2	3/8 - 18	2.99	2.30	1-1/8	15,000
8-8 GBMP7	1/2	1/2 - 14	3.20	2.51	1-3/8	15,000
9-4 GBMP7	9/16	1/4 - 18	2.68	2.18	1-3/8	15,000
9-6 GBMP7	9/16	3/8 - 18	2.93	2.30	1-1/8	15,000
9-8 GBMP7	9/16	1/2 - 14	3.26	2.51	1-3/8	15,000
10-8 GBMP7	5/8	1/2 - 14	3.26	2.51	1-3/8	15,000
12-8 GBMP7	3/4	1/2 - 14	3.70	2.82	1-3/8	15,000

Dimensions in inches are for reference only, subject to change.

MPI™  
Fittings

## MP7HBA

MPI™ to SAE Male  
O-Ring Connector

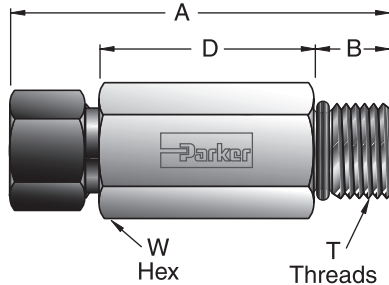

Parker Part No.	Inches							Working Pressure (PSIG)
	MPI™ Size	SAE* End	A	B	D	T Thread	W Hex	
4-4 MP7HBA	1/4	1/4	1.90	.43	.97	7/16 - 20	5/8	12,500
4-6 MP7HBA	1/4	3/8	1.94	.47	.97	9/16 - 18	11/16	12,500
4-8 MP7HBA	1/4	1/2	1.97	.55	.91	3/4 - 16	7/8	12,500
6-4 MP7HBA	3/8	1/4	2.41	.43	1.35	7/16 - 20	3/4	12,500
6-6 MP7HBA	3/8	3/8	2.20	.47	1.10	9/16 - 18	3/4	12,500
6-8 MP7HBA	3/8	1/2	2.23	.55	1.05	3/4 - 16	7/8	12,500
8-4 MP7HBA	1/2	1/4	2.81	.43	1.69	7/16 - 20	1	12,500
8-6 MP7HBA	1/2	3/8	2.82	.47	1.66	9/16 - 18	1	12,500
8-8 MP7HBA	1/2	1/2	2.60	.55	1.36	3/4 - 16	1	12,500
9-6 MP7HBA	9/16	3/8	2.89	.47	1.67	9/16 - 18	1-1/16	12,500
9-8 MP7HBA	9/16	1/2	2.89	.55	1.59	3/4 - 16	1-1/16	12,500

\*All male o-ring ends for MPI™ fittings are heavy duty and comply with SAE J1926/2. This end has maximum thread engagement for strength and requires the minimum full thread engagement specified in SAE J1926/1 for the female port.

Standard O-ring material is Nitrile #N0552-90.

Dimensions in inches are for reference only, subject to change.

## M40HBMP7

Type "M" High Pressure Hose  
to MPI™ Connector

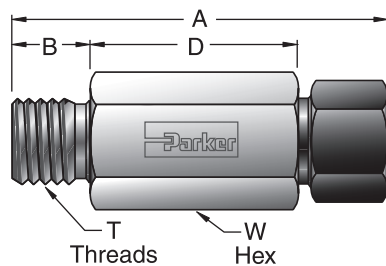

Parker Part No.	Inches							Working Pressure (PSIG)
	Hose* Adapter	MPI™ Size	A	B	D	T Thread	W Hex	
6-4 M40HBMP7	-6	1/4	2.03	.50	1.03	9/16 - 18	5/8	15,000
6-6 M40HBMP7	-6	3/8	2.45	.50	1.32	9/16 - 18	3/4	15,000
8-6 M40HBMP7	-8	3/8	2.57	.63	1.32	3/4 - 16	13/16	15,000
8-8 M40HBMP7	-8	1/2	2.90	.63	1.59	3/4 - 16	3/4 - 16	15,000
8-9 M40HBMP7	-8	9/16	2.97	.63	1.59	3/4 - 16	1-1/16	15,000
10-4 M40HBMP7	-10	1/4	2.39	.75	1.14	7/8 - 14	15/16	15,000
10-6 M40HBMP7	-10	3/8	2.72	.75	1.34	7/8 - 14	15/16	15,000
11-8 M40HBMP7	-11	1/2	2.89	.63	1.58	1 - 12	1-1/16	15,000
11-9 M40HBMP7	-11	9/16	2.95	.63	1.58	1 - 12	1-1/16	15,000
11-12 M40HBMP7	-11	3/4	3.59	.63	2.08	1 - 12	1-3/8	15,000
16-16 M40HBMP7	-16	1	3.88	.63	2.13	1-5/16 - 12	1-3/4	12,500

\* Adapts to Type "M" Swivel Hose Connection.

Dimensions in inches are for reference only, subject to change.

## GH2BMP7

MPI™ Bulkhead to Female NPT Connector

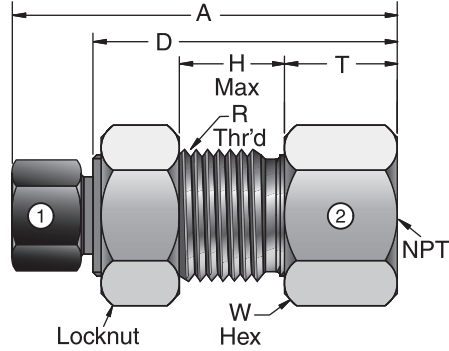

Parker Part No.	Inches								Working Pressure (PSIG)
	MPI™ Size	NPT Thread	A	D	H Max.	R Thread	T	W Hex	
4-4 GH2BMP7	1/4	1/4 -18	2.38	1.88	.63	3/4 - 20	.75	1	15,000
6-8 GH2BMP7	3/8	1/2 -14	3.13	2.50	.63	7/8 - 20	1.25	1-3/8	15,000
6-12 GH2BMP7	3/8	3/4 -14	3.19	2.56	.69	7/8 - 20	1.31	1-1/2	10,000
8-12 GH2BMP7	1/2	3/4 -14	3.50	2.81	.81	1-1/8 - 20	1.31	1-1/2	10,000
9-4 GH2BMP7	9/16	1/4 -18	2.82	2.07	.73	1-1/8 - 20	.69	1-3/8	15,000

\* Bulkhead hole approximately 1/64" (.015") larger than R Thread major diameter.  
Dimensions in inches are for reference only, subject to change.

## HBMP7

MPI™ Union Connector

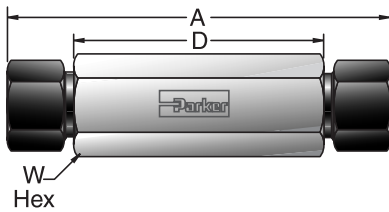

Parker Part No.	Inches				Working Pressure (PSIG)
	MPI™ Size	A	D	W Hex	
4-4 HBMP7	1/4	2.88	1.88	5/8	15,000
6-4 HBMP7	3/8 - 1/4	3.32	2.19	3/4	15,000
6-6 HBMP7	3/8	3.44	2.19	3/4	15,000
8-4 HBMP7	1/2 - 1/4	3.88	2.70	1	15,000
8-6 HBMP7	1/2 - 3/8	4.01	2.70	1	15,000
8-8 HBMP7	1/2	4.07	2.70	1	15,000
9-4 HBMP7	9/16 - 1/4	3.95	2.70	1-1/16	15,000
9-6 HBMP7	9/16 - 3/8	4.07	2.70	1-1/16	15,000
9-8 HBMP7	9/16 - 1/2	4.13	2.70	1-1/16	15,000
9-9 HBMP7	9/16	4.20	2.70	1-1/16	15,000
10-10 HBMP7	5/8	4.42	2.92	1-3/16	15,000
12-6 HBMP7	3/4 - 3/8	4.76	3.25	1-3/8	15,000
12-9 HBMP7	3/4 - 9/16	5.15	3.51	1-3/8	15,000
12-12 HBMP7	3/4	5.08	3.31	1-3/8	15,000
16-16 HBMP7	1	6.52	4.25	1-3/4	12,500

Dimensions in inches are for reference only, subject to change.

MPI™ Fittings

## WBMP7

MPI™ Bulkhead Union Connector

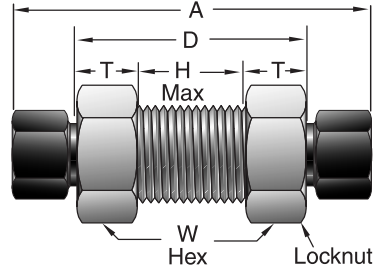

Parker Part No.	MPI™ Size	Inches						Working Pressure (PSIG)
		A	D	H Max.	R Thread	T	W Hex	
4-4 WBMP7	1/4	2.88	1.88	.88	3/4 - 20	.50	1	15,000
6-6 WBMP7	3/8	3.44	2.19	1.07	7/8 - 20	.56	1-1/8	15,000
8-8 WBMP7	1/2	4.07	2.70	1.32	1-1/8 - 20	.69	1-3/8	10,000
8-9 WBMP7	1/2 - 9/16	4.20	2.70	1.32	1-1/8 - 20	.69	1-3/8	10,000
9-8 WBMP7	9/16 - 1/2	4.20	2.70	1.32	1-1/8 - 20	.69	1-3/8	15,000
9-9 WBMP7	9/16	4.20	2.70	1.32	1-1/8 - 20	.69	1-3/8	15,000
12-12 WBMP7	3/4	5.08	3.31	1.56	1-7/16 - 18	.88	1-7/8	15,000
16-16 WBMP7	1	6.52	4.25	2.00	1-7/8 - 12	1.13	2-1/2	12,500

\* Bulkhead hole approximately 1/64" (.015") larger than R Thread major diameter.  
Dimensions in inches are for reference only, subject to change.

## GM7

MPI™ Male End to Female NPT

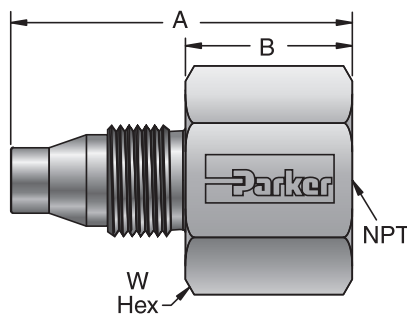

Parker Part No.	MPI™ Male Thread <sup>1</sup>	Female NPT End	Inches				Working Pressure (PSIG)
			A	B	NPT Thread	W Hex	
4-4 GM7	1/4	1/4	1.73	.85	1/4 - 18	1	15,000
4-6 GM7	1/4	3/8	1.83	.95	3/8 - 18	1-1/8	15,000
6-4 GM7	3/8	1/4	1.84	.85	1/4 - 18	1	15,000
6-6 GM7	3/8	3/8	1.94	.95	3/8 - 18	1-1/8	15,000
6-8 GM7	3/8	1/2	2.17	1.17	1/2 - 14	1-3/8	15,000
8-4 GM7	1/2	1/4	2.05	.85	1/4 - 18	1	15,000
8-6 GM7	1/2	3/8	2.15	.95	3/8 - 18	1-1/8	15,000
8-8 GM7	1/2	1/2	2.37	1.17	1/2 - 14	1-3/8	15,000
9-4 GM7	9/16	1/4	2.05	.85	1/4 - 18	1	15,000
9-6 GM7	9/16	3/8	2.15	.95	3/8 - 18	1-1/8	15,000
9-8 GM7	9/16	1/2	2.37	1.17	1/2 - 14	1-3/8	15,000
12-4 GM7	3/4	1/4	2.17	.75	1/4 - 18	1-1/4	15,000
12-6 GM7	3/4	3/8	2.17	.75	3/8 - 18	1-1/4	15,000
12-8 GM7	3/4	1/2	2.59	1.17	1/2 - 14	1-3/8	15,000

<sup>1</sup>Assemble 1/4 to 1/2 turn from finger tight & lubricate threads & taper before each remake.  
Dimensions in inches are for reference only, subject to change.

## GM7

MPI™ Male End to High Pressure C&T Port

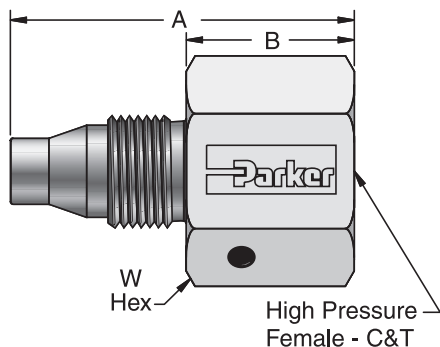

Parker Part No.	Inches						Working Pressure (PSIG)
	MPI™ Male Thread <sup>1</sup>	High Press. C&T Port	A	B	C&T Thread	W Hex	
4-4HF GM7	1/4	1/4	1.57	.69	9/16 - 18	3/4	15,000
6-4HF GM7	3/8	1/4	1.68	.69	9/16 - 18	3/4	15,000
6-6HF GM7	3/8	3/8	1.87	.88	3/4 - 16	1	15,000
8-4HF GM7	1/2	1/4	1.89	.69	9/16 - 18	15/16	15,000
8-6HF GM7	1/2	3/8	2.07	.88	3/4 - 16	1	15,000
9-4HF GM7	9/16	1/4	1.89	.69	9/16 - 18	1	15,000
9-6HF GM7	9/16	3/8	2.07	.88	3/4 - 16	1	15,000
12-4HF GM7	3/4	1/4	2.17	.75	9/16 - 18	1-1/4	15,000
12-6HF GM7	3/4	3/8	2.30	.88	3/4 - 16	1-1/4	15,000

<sup>1</sup>Assemble 1/4 to 1/2 turn from finger tight & lubricate threads & taper before each remake. Dimensions in inches are for reference only, subject to change.

## T7HBT7

MPI™ Tube Port Connector

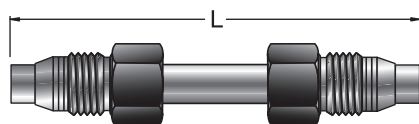

Parker Part No.	Inches		Working Pressure (PSIG)
	Tube Size	L	
*4 T7HBT7-SS	1/4	2.72	15,000
4 T7HBT7-SS 4.0	1/4	4.00	15,000
4 T7HBT7-SS 6.0	1/4	6.00	15,000
4 T7HBT7-SS7 8.0	1/4	8.00	15,000
4 T7HBT7-SS 10.0	1/4	10.00	15,000
4 T7HBT7-SS 12.0	9/16	12.00	15,000
*6 T7HBT7-SS	3/8	3.19	15,000
6 T7HBT7-SS 4.0	3/8	4.00	15,000
6 T7HBT7-SS 6.0	3/8	6.00	15,000
6 T7HBT7-SS 8.0	3/8	8.00	15,000
6 T7HBT7-SS 10.0	3/8	10.00	15,000
6 T7HBT7-SS 12.0	3/8	12.00	15,000
*9 T7HBT7-SS	9/16	3.85	15,000
9 T7HBT7-SS 6.0	9/16	6.00	15,000
9 T7HBT7-SS 8.0	9/16	8.00	15,000
9 T7HBT7-SS 10.0	9/16	10.00	15,000
9 T7HBT7-SS7 12.0	9/16	12.00	15,000
*12 T7HBT7-SS	3/4	4.55	15,000
12 T7HBT7-SS 6.0	3/4	6.00	15,000
12 T7HBT7-SS 8.0	3/4	8.00	15,000
12 T7HBT7-SS 10.0	3/4	10.00	15,000
12 T7HBT7-SS 12.0	3/4	12.00	15,000

Assemble 1/2 turn from finger tight.

\*Same Assembled Length as MP7PC.

Replace "SS" with "2507" for Super Duplex

Dimensions in inches are for reference only, subject to change.



# MPI™ Medium Pressure Products

## T7HF

MPI™ Tube Stub to Male NPT Pipe

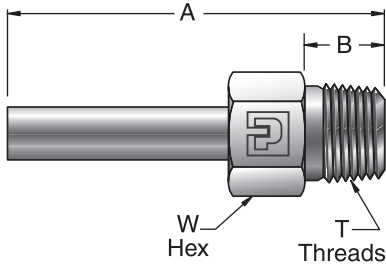

Parker Part No.	Inches						Working Pressure (PSIG)
	MPI™ Tube Stub	Male NPT End	A	B	NPT Thread	W Hex	
4-4 T7HF	1/4	1/4	2.32	.57	1/4 - 18	5/8	15,000
4-6 T7HF	1/4	3/8	2.44	.57	3/8 - 18	3/4	15,000
4-8 T7HF	1/4	1/2	2.76	.76	1/2 - 14	7/8	15,000
6-4 T7HF	3/8	1/4	2.56	.57	1/4 - 18	5/8	15,000
6-6 T7HF	3/8	3/8	2.68	.57	3/8 - 18	3/4	15,000
6-8 T7HF	3/8	1/2	2.99	.76	1/2 - 14	7/8	15,000
8-4 T7HF	1/2	1/4	2.82	.57	1/4 - 18	5/8	15,000
8-6 T7HF	1/2	3/8	2.95	.57	3/8 - 18	3/4	15,000
8-8 T7HF	1/2	1/2	3.26	.76	1/2 - 14	7/8	15,000
9-4 T7HF	9/16	1/4	2.88	.57	1/4 - 18	5/8	15,000
9-6 T7HF	9/16	3/8	3.01	.57	3/8 - 18	3/4	15,000
9-8 T7HF	9/16	1/2	3.32	.76	1/2 - 14	7/8	15,000
9-12 T7HF	9/16	3/4	3.43	.76	3/4 - 14	1-1/8	10,000
12-8 T7HF	3/4	1/2	3.67	.76	1/2 - 14	7/8	15,000
12-12 T7HF	3/4	3/4	3.80	.76	3/4 - 14	1-1/8	10,000

Add "-Z6" to part number for part assembled with preset ferrules and nuts.  
Dimensions in inches are for reference only, subject to change.

## XHT7

37° Flare to MPI™ Tube Stub

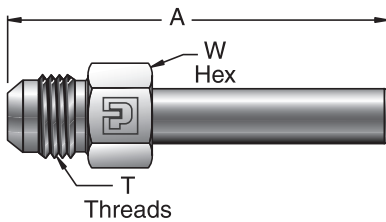

Parker Part No.	Inches					Working Pressure (PSIG)
	37° Flare Adapter Size	MPI™ Tube Stub	A	T Thread	W Hex	
4-4 XHT7	1/4	1/4	2.24	7/16 - 20	1/2	15,000
4-6 XHT7	1/4	3/8	2.47	7/16 - 20	1/2	15,000
6-4 XHT7	3/8	1/4	2.37	9/16 - 18	5/8	12,500
6-6 XHT7	3/8	3/8	2.60	9/16 - 18	5/8	12,500
6-8 XHT7	3/8	1/2	2.87	9/16 - 18	5/8	12,500
6-9 XHT7	3/8	9/16	2.93	9/16 - 18	5/8	12,500
8-6 XHT7	1/2	3/8	2.77	3/4 - 16	13/16	12,500
8-8 XHT7	1/2	1/2	3.04	3/4 - 16	13/16	12,500
8-9 XHT7	1/2	9/16	3.10	3/4 - 16	13/16	12,500

Add "-Z6" to part number for part assembled with preset ferrules and nuts.  
Dimensions in inches are for reference only, subject to change.



## X41HT7

High Pressure to MPI™ Tube Stub

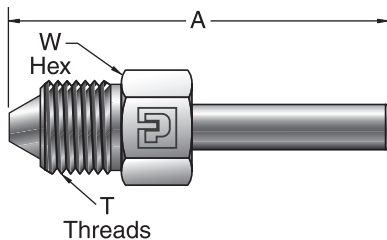

Parker Part No.	Inches					Working Pressure (PSIG)
	High Pressure Adapter Size	MPI™ Tube Stub	A	T Thread	W Hex	
4-4 X41HT7	1/4	1/4	2.59	9/16 - 18	5/8	15,000
4-6 X41HT7	1/4	3/8	2.83	9/16 - 18	5/8	15,000
4-8 X41HT7	1/4	1/2	3.10	9/16 - 18	5/8	15,000
4-9 X41HT7	1/4	9/16	3.16	9/16 - 18	5/8	15,000
6-4 X41HT7	3/8	1/4	2.92	3/4 - 16	13/16	15,000
6-6 X41HT7	3/8	3/8	3.16	3/4 - 16	13/16	15,000
6-8 X41HT7	3/8	1/2	3.43	3/4 - 16	13/16	15,000
6-9 X41HT7	3/8	9/16	3.49	3/4 - 16	13/16	15,000
9-4 X41HT7	9/16	1/4	3.25	1-1/8 - 12	1-13/16	15,000
9-6 X41HT7	9/16	3/8	3.49	1-1/8 - 12	1-13/16	15,000
9-8 X41HT7	9/16	1/2	3.75	1-1/8 - 12	1-13/16	15,000
9-9 X41HT7	9/16	9/16	3.82	1-1/8 - 12	1-13/16	15,000

Add "-Z6" to part number for part assembled with preset ferrules and nuts.  
Dimensions in inches are for reference only, subject to change.

MPI™  
Fittings

## X47HT7

Medium Pressure Port Connector to MPI™ Tube Stub

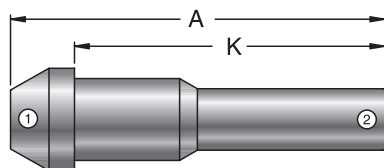

Parker Part No.	Inches				Working Pressure (PSIG)
	MP Port Connector #1	MP Port Connector #2	A	K	
9-6 X47HT7	9/16	3/8	3.21	1.61	15,000
9-9 X47HT7	9/16	9/16	3.53	3.03	15,000
12-9 X47HT7	3/4	9/16	3.72	1.94	15,000
12-12 X47HT7	3/4	3/4	4.07	3.44	15,000
16-9 X47HT7	1	9/16	4.23	3.44	15,000
16-12 X47HT7	1	3/4	4.57	3.79	15,000
16-16 X47HT7	1	1	5.19	4.41	12,500

End # 1 must be used with a Medium Pressure Gland.  
Add "-Z6" to part number for part assembled with preset ferrules and nuts.  
Dimensions in inches are for reference only, subject to change.

## X42HT7

Medium Pressure to MPI™ Tube Stub

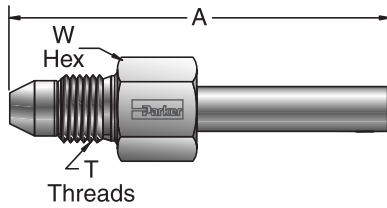

Parker Part No.	Inches					Working Pressure (PSIG)
	Medium Pressure Adapter Size	MPI™ Tube Stub	A	T Thread	W Hex	
4-4 X42HT7	1/4	1/4	2.68	7/16 - 20	5/8	15,000
4-6 X42HT7	1/4	3/8	2.92	7/16 - 20	5/8	15,000
4-8 X42HT7	1/4	1/2	3.18	7/16 - 20	5/8	15,000
4-9 X42HT7	1/4	9/16	3.25	7/16 - 20	5/8	15,000
6-4 X42HT7	3/8	1/4	2.94	9/16 - 18	3/4	15,000
6-6 X42HT7	3/8	3/8	3.17	9/16 - 18	3/4	15,000
6-8 X42HT7	3/8	1/2	3.44	9/16 - 18	3/4	15,000
6-9 X42HT7	3/8	9/16	3.50	9/16 - 18	3/4	15,000
9-4 X42HT7	9/16	1/4	3.25	13/16 - 16	7/8	15,000
9-6 X42HT7	9/16	3/8	3.49	13/16 - 16	7/8	15,000
9-8 X42HT7	9/16	1/2	3.75	13/16 - 16	7/8	15,000
9-9 X42HT7	9/16	9/16	3.81	13/16 - 16	7/8	15,000
9-12 X42HT7	9/16	3/4	4.16	13/16 - 16	7/8	15,000
12-9 X42HT7	3/4	9/16	4.00	3/4 - 14 NPS	1-1/8	15,000
12-12 X42HT7	3/4	3/4	4.35	3/4 - 14 NPS	1-1/8	15,000

Add "-Z6" to part number for part assembled with preset ferrules and nuts.  
Dimensions in inches are for reference only, subject to change.

## T7HOA

MPI™ Tube Stub to Male SAE O-ring

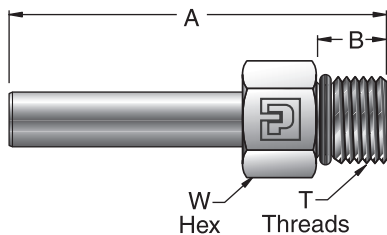

Parker Part No.	Inches					Working Pressure (PSIG)	
	MPI™ Tube Stub	SAE Oring End	A	B	T Thread		W Hex
4-4 T7HOA	1/4	1/4	2.25	.43	7/16 - 20	9/16	12,500
4-6 T7HOA	1/4	3/8	2.35	.47	9/16 - 18	11/16	12,500
4-8 T7HOA	1/4	1/2	2.49	.55	3/4 - 16	7/8	12,500
6-4 T7HOA	3/8	1/4	2.48	.43	7/16 - 20	9/16	12,500
6-6 T7HOA	3/8	3/8	2.58	.47	9/16 - 18	11/16	12,500
6-8 T7HOA	3/8	1/2	2.72	.55	3/4 - 16	7/8	12,500
8-4 T7HOA	1/2	1/4	2.75	.43	7/16 - 20	9/16	12,500
8-6 T7HOA	1/2	3/8	2.85	.47	9/16 - 18	11/16	12,500
8-8 T7HOA	1/2	1/2	2.99	.55	3/4 - 16	7/8	12,500
9-4 T7HOA	9/16	1/4	2.81	.43	7/16 - 20	5/8	12,500
9-6 T7HOA	9/16	3/8	2.91	.47	9/16 - 18	11/16	12,500
9-8 T7HOA	9/16	1/2	3.05	.55	3/4 - 16	7/8	12,500

Add "-Z6" to part number for part assembled with preset ferrules and nuts.  
\* All male o-ring ends for MPI™ fittings are heavy duty and comply with SAE J1926-2. This end has maximum thread engagement for strength and requires the minimum full thread engagement specified in SAE J9126 for the female port. Standard O-ring material is Nitrile #N0552-90.  
Dimensions in inches are for reference only, subject to change.

## M40HT7

Type "M" High Pressure Hose Adapter to MPI™ Tube Stub

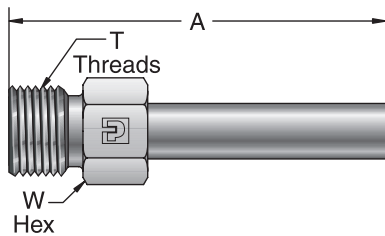

Parker Part No.	Inches					Working Pressure (PSIG)
	Hose* Adapter Size	MPI™ Tube Stub	A	T Thread	W Hex	
6-4 M40HT7	-6	1/4	2.31	9/16 - 18	5/8	15,000
6-6 M40HT7	-6	3/8	2.55	9/16 - 18	5/8	15,000
8-6 M40HT7	-8	3/8	2.74	3/4 - 16	13/16	15,000
8-9 M40HT7	-8	9/16	3.12	3/4 - 16	13/16	15,000
11-6 M40HT7	-11	3/8	2.99	1 - 12	1-1/16	15,000
11-9 M40HT7	-11	9/16	3.31	1 - 12	1-1/16	15,000
11-12 M40HT7	-11	3/4	3.66	1 - 12	1-1/16	15,000
16-12 M40HT7	-16	3/4	3.91	1-5/16 - 12	1-3/8	15,000
16-16 M40HT7	-16	1	4.51	1-5/16 - 12	1-3/8	12,500

Add "-Z6" to part number for part assembled with preset ferrules and nuts.  
 Dimensions in inches are for reference only, subject to change.  
 Adapts to Type "M" Swivel Hose Connection

## TRBMP7

MPI™ Tube Stub Reducer

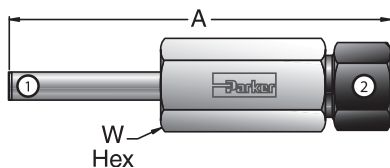

Parker Part No.	Inches				Working Pressure (PSIG)
	MPI™ Tube Stub #1	MPI™ Size #2	A	W Hex	
4-6 TRBMP7	1/4	3/8	3.49	3/4	15,000
4-8 TRBMP7	1/4	1/2	3.94	1	15,000
4-9 TRBMP7	1/4	9/16	4.00	1-1/16	15,000
6-4 TRBMP7	3/8	1/4	3.30	5/8	15,000
6-8 TRBMP7	3/8	1/2	4.17	1	15,000
6-9 TRBMP7	3/8	9/16	4.24	1-1/16	15,000
8-4 TRBMP7	1/2	1/4	3.56	5/8	15,000
8-6 TRBMP7	1/2	3/8	3.99	3/4	15,000
9-4 TRBMP7	9/16	1/4	3.63	5/8	15,000
9-6 TRBMP7	9/16	3/8	4.06	3/4	15,000
9-12 TRBMP7	9/16	3/4	4.97	1-3/8	15,000
12-4 TRBMP7	3/4	1/4	4.17	13/16	15,000
12-6 TRBMP7	3/4	3/8	4.42	13/16	15,000
12-9 TRBMP7	3/4	9/16	4.82	1-1/16	15,000

Add "-Z6" to part number for part assembled with preset ferrules and nuts.  
 Dimensions in inches are for reference only, subject to change.



# MPI™ Medium Pressure Products

## T7HG

MPI™ Tube Stub to Female NPT Pipe

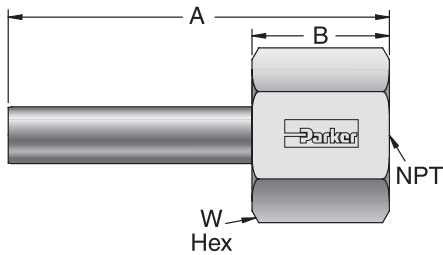

Parker Part No.	Inches						Working Pressure (PSIG)
	MPI™ Tube Stub	Female NPT End	A	B	NPT Thread	W Hex	
4-2 T7HG	1/4	1/8	2.09	.72	1/8 - 27	13/16	15,000
4-4 T7HG	1/4	1/4	2.28	.91	1/4 - 18	1	15,000
4-8 T7HG	1/4	1/2	2.64	1.27	1/2 - 14	1-3/8	15,000
6-2 T7HG	3/8	1/8	2.33	.72	1/8 - 27	13/16	15,000
6-4 T7HG	3/8	1/4	2.52	.91	1/4 - 18	1	15,000
6-8 T7HG	3/8	1/2	2.88	1.27	1/2 - 14	1-3/8	15,000
8-2 T7HG	1/2	1/8	2.60	.72	1/8 - 27	13/16	15,000
8-4 T7HG	1/2	1/4	2.79	.91	1/4 - 18	1	15,000
8-8 T7HG	1/2	1/2	3.14	1.27	1/2 - 14	1-3/8	12,500
9-4 T7HG	9/16	1/4	2.84	.91	1/4 - 18	1	15,000
9-8 T7HG	9/16	1/2	3.20	1.27	1/2 - 14	1-3/8	15,000
12-8 T7HG	3/4	1/2	3.55	1.27	1/2 - 14	1-3/8	15,000
12-12 T7HG	3/4	3/4	3.60	1.31	3/4 - 11 1/2	1-1/2	10,000
16-16 T7HG	1	1	4.38	1.50	1 - 11 1/2	1-7/8	10,000

Add “-Z6” to part number for part assembled with preset ferrules and nuts.  
Dimensions in inches are for reference only, subject to change.

## MP7PC

MPI™ Port Connector

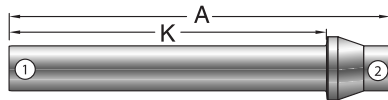

Parker Part No.	Inches				Working Pressure (PSIG)
	MPI™ Tube Stub #1	MPI™ Tube Stub #2 <sup>1</sup>	A	K	
4-4 MP7PC	1/4	1/4	2.69	2.23	15,000
4-6 MP7PC	1/4	3/8	2.93	2.40	15,000
6-6 MP7PC	3/8	3/8	3.17	2.64	15,000
6-8 MP7PC	3/8	1/2	3.43	2.68	15,000
6-9 MP7PC	3/8	9/16	3.50	2.75	15,000
8-8 MP7PC	1/2	1/2	3.70	2.95	15,000
9-9 MP7PC	9/16	9/16	3.82	3.07	15,000
9-12 MP7PC	9/16	3/4	4.17	3.32	15,000
12-12 MP7PC	3/4	3/4	4.52	3.67	15,000
12-16 MP7PC	3/4	1	5.12	4.07	12,500
16-16 MP7PC	1	1	5.74	4.70	12,500

<sup>1</sup> Assemble 1/4 to 1/2 turn from finger tight.  
Add “-Z6” to part number for part assembled with preset ferrules and nuts.  
Dimensions in inches are for reference only, subject to change.

## NBMP7

45° MPI™ Union Elbow

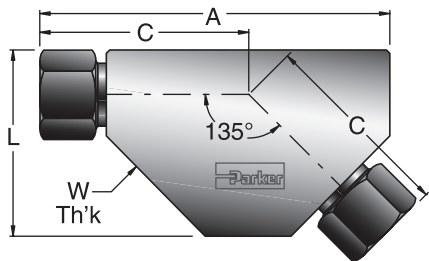

Parker Part No.	MPI™ Size	Inches				Working Pressure (PSIG)
		A	C	L	W Th'k	
4-4 NBMP7	1/4	2.56	1.50	1.38	5/8	15,000
6-6 NBMP7	3/8	3.10	1.81	1.63	3/4	15,000
8-8 NBMP7	1/2	3.76	2.18	2.13	1	15,000
9-9 NBMP7	9/16	3.82	2.24	2.13	1	15,000
12-12 NBMP7	3/4	4.76	2.82	2.63	1-3/8	15,000

Dimensions in inches are for reference only, subject to change.

Note: Body shape may vary with size/configuration. Consult factory for size-specific drawing.

## T7NBT7

45° MPI™ Tube Stub Elbow

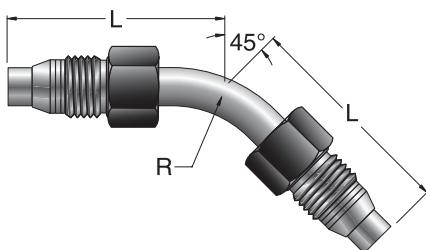

Parker Part No.	Tube Size	Inches		Working Pressure (PSIG)
		L	R	
4 T7NBT7-SS	1/4	1.69	0.75	15,000
*4 T7NBT7-SS 2.9	1/4	2.88	0.75	15,000
4 T7NBT7-SS 6.0	1/4	6.00	0.75	15,000
4 T7NBT7-SS 8.0	1/4	8.00	0.75	15,000
4 T7NBT7-SS 10.0	1/4	10.00	0.75	15,000
4 T7NBT7-SS 12.0	1/4	12.00	0.75	15,000
6 T7NBT7-SS	3/8	2.14	1.25	15,000
*6 T7NBT7-SS 3.4	3/8	3.42	1.25	15,000
6 T7NBT7-SS 6.0	3/8	6.00	1.25	15,000
6 T7NBT7-SS 8.0	3/8	8.00	1.25	15,000
6 T7NBT7-SS 10.0	3/8	10.00	1.25	15,000
6 T7NBT7-SS 12.0	3/8	12.00	1.25	15,000
9 T7NBT7-SS	9/16	2.77	2.00	15,000
*9 T7NBT7-SS 4.2	9/16	4.18	2.00	15,000
9 T7NBT7-SS 6.0	9/16	6.00	2.00	15,000
9 T7NBT7-SS 8.0	9/16	8.00	2.00	15,000
9 T7NBT7-SS 10.0	9/16	10.00	2.00	15,000
9 T7NBT7-SS 12.0	9/16	12.00	2.00	15,000
12 T7NBT7-SS	3/4	3.55	3.00	15,000
12 T7NBT7-SS 5.1	3/4	5.11	3.00	15,000
12 T7NBT7-SS 6.0	3/4	6.00	3.00	15,000
12 T7NBT7-SS 8.0	3/4	8.00	3.00	15,000
12 T7NBT7-SS 10.0	3/4	10.00	3.00	15,000
12 T7NBT7-SS 12.0	3/4	12.00	3.00	15,000

Assemble 1/2 turn from finger tight.

\* Similar Assembled Lengths as NBMP7 with two (2) MP7PCs.

Replace "SS" with "2507" for Super Duplex

Dimensions in inches are for reference only, subject to change.



# MPI™ Medium Pressure Products

## EBMP7

MPI™ Union Elbow

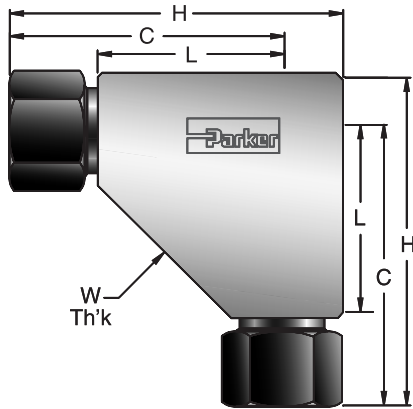

Parker Part No.	Inches					Working Pressure (PSIG)
	MPI™ Size	C	H	L	W Th'k	
4-4 EBMP7	1/4	1.53	1.88	1.03	5/8	15,000
6-6 EBMP7	3/8	1.86	2.25	1.24	3/4	15,000
8-8 EBMP7	1/2	2.22	2.81	1.54	1	15,000
9-9 EBMP7	9/16	2.29	2.88	1.54	1	15,000
10-10 EBMP7	5/8	2.46	3.09	1.71	1-3/16	15,000
*12-12 EBMP7	3/4	2.82	3.51	1.94	1-3/8	15,000
*16-16 EBMP7	1	3.63	4.51	2.50	1-3/4	12,500

Dimensions in inches are for reference only, subject to change.

\* Sizes 12 and 16 utilize a square shaped body, all others use the triangular shaped body shown.

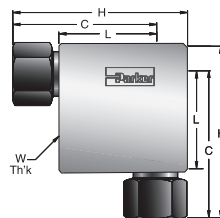

## T7EBT7

MPI™ Tube Elbow

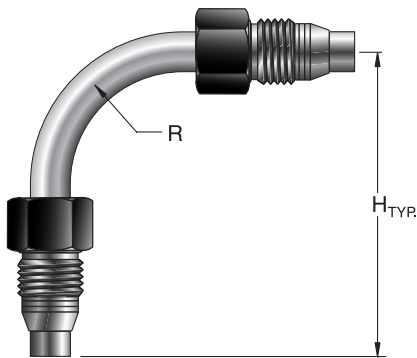

Parker Part No.	Inches			Working Pressure (PSIG)
	Tube Size	H	R	
4 T7EBT7-SS	1/4	2.12	0.75	15,000
*4 T7EBT7-SS 2.9	1/4	2.91	0.75	15,000
4 T7EBT7-SS 6.0	1/4	6.00	0.75	15,000
4 T7EBT7-SS 8.0	1/4	8.00	0.75	15,000
4 T7EBT7-SS 10.0	1/4	10.00	0.75	15,000
4 T7EBT7-SS 12.0	1/4	12.00	0.75	15,000
6 T7EBT7-SS	3/8	2.88	1.25	15,000
*6 T7EBT7-SS 3.5	3/8	3.47	1.25	15,000
6 T7EBT7-SS 6.0	3/8	6.00	1.25	15,000
6 T7EBT7-SS 8.0	3/8	8.00	1.25	15,000
6 T7EBT7-SS 10.0	3/8	10.00	1.25	15,000
6 T7EBT7-SS 12.0	3/8	12.00	1.25	15,000
*9 T7EBT7-SS	9/16	4.22	2.00	15,000
9 T7EBT7-SS 6.0	9/16	6.00	2.00	15,000
9 T7EBT7-SS 8.0	9/16	8.00	2.00	15,000
9 T7EBT7-SS 10.0	9/16	10.00	2.00	15,000
9 T7EBT7-SS 12.0	9/16	12.00	2.00	15,000
12 T7EBT7-SS	3/4	5.31	3.00	15,000
12 T7EBT7-SS 6.0	3/4	6.00	3.00	15,000
12 T7EBT7-SS 8.0	3/4	8.00	3.00	15,000
12 T7EBT7-SS 10.0	3/4	10.00	3.00	15,000
12 T7EBT7-SS 12.0	3/4	12.00	3.00	15,000

Assemble 1/2 turn from finger tight.

\* Similar Assembled Lengths as EBMP7 with two (2) MP7PCs.

Replace "SS" with "2507" for Super Duplex

Dimensions in inches are for reference only, subject to change.



## CBMP7

MPI™ to Male NPT Elbow

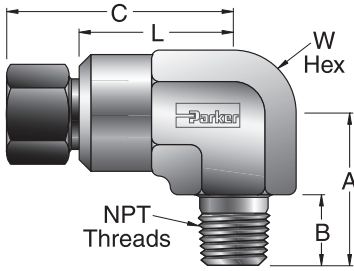

Parker Part No.	Inches							Working Pressure (PSIG)
	MPI™ Size	NPT Thread	A	B	C	L	W Th'k	
4-4 CBMP7	1/4	1/4 - 18	1.13	.57	1.53	1.03	3/4	15,000
4-6 CBMP7	1/4	3/8 - 18	1.13	.57	1.56	1.06	3/4	12,000
4-8 CBMP7	1/4	1/2 - 18	1.41	.76	1.64	1.14	3/4	10,000
6-4 CBMP7	3/8	1/4 - 18	1.23	.57	1.86	1.24	7/8	12,500
6-6 CBMP7	3/8	3/8 - 18	1.23	.57	1.86	1.24	7/8	12,000
6-8 CBMP7	3/8	1/2 - 14	1.41	.76	1.92	1.30	7/8	10,000

Dimensions in inches are for reference only, subject to change.

## JBMP7

MPI™ Union Tee

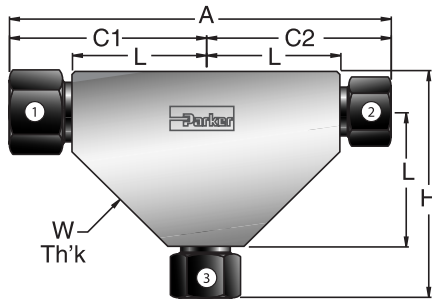

Parker Part No.	Inches									Working Pressure (PSIG)
	MPI™ Size #1	MPI™ Size #2	MPI™ Size #3	A	C1	C2	H	L	W Th'k	
4-4-4 JBMP7	1/4	1/4	1/4	3.06	1.53	1.53	1.88	1.03	5/8	15,000
6-6-6 JBMP7	3/8	3/8	3/8	3.72	1.86	1.86	2.25	1.24	3/4	15,000
8-8-8 JBMP7	1/2	1/2	1/2	4.45	2.22	2.22	2.81	1.54	1	15,000
9-9-9 JBMP7	9/16	9/16	9/16	4.57	2.29	2.29	2.88	1.54	1	15,000
10-10-10 JBMP7	5/8	5/8	5/8	5.00	2.50	2.50	3.10	1.75	1-3/16	15,000
12-12-12 JBMP7	3/4	3/4	3/4	5.64	2.82	2.82	3.51	1.94	1-3/8	15,000
16-16-16 JBMP7	1	1	1	7.27	3.63	3.63	4.51	2.50	1-3/4	12,500
4-4-6 JBMP7	1/4	1/4	3/8	3.47	1.74	1.74	2.25	1.24	3/4	15,000
6-6-4 JBMP7	3/8	3/8	1/4	3.72	1.86	1.86	2.13	1.24	3/4	15,000
6-4-4 JBMP7	3/8	1/4	1/4	3.60	1.86	1.74	2.13	1.24	3/4	15,000
6-6-8 JBMP7	3/8	3/8	1/2	4.32	2.16	2.16	2.81	1.54	1	15,000
6-6-9 JBMP7	3/8	3/8	9/16	4.45	2.16	2.29	2.88	1.54	1	15,000
8-8-6 JBMP7	1/2	1/2	3/8	4.45	2.22	2.22	2.75	1.54	1	15,000
8-6-6 JBMP7	1/2	3/8	3/8	4.38	2.22	2.16	2.75	1.54	1	15,000
9-9-4 JBMP7	9/16	9/16	1/4	4.57	2.29	2.29	2.63	1.54	1	15,000
9-9-6 JBMP7	9/16	9/16	3/8	4.57	2.29	2.29	2.75	1.54	1	15,000
9-6-4 JBMP7	9/16	3/8	1/4	4.45	2.29	2.16	2.63	1.54	1	15,000
9-6-6 JBMP7	9/16	3/8	1/4	4.45	2.29	2.16	2.75	1.54	1	15,000
12-12-9 JBMP7	3/4	3/4	9/16	5.64	2.82	2.82	3.38	1.94	1-3/8	15,000
16-16-9 JBMP7	1	1	9/16	7.27	3.63	3.63	4.13	2.50	1-3/4	12,500
16-16-12 JBMP7	1	1	3/4	7.27	3.63	3.63	4.26	2.50	1-3/4	12,500

Dimensions in inches are for reference only, subject to change.

Note: Body shape may vary with size/configuration. Consult factory for size-specific drawing.

## X44HBMP7

X44 Male by MPI™ Connector

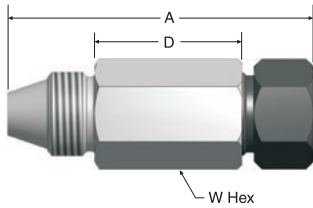

Parker Part No.	Inches					Working Pressure (PSIG)
	X44 Adapter	MPI™ Size	A	D	W Th'k	
9-9 X44HBMP7	9/16	9/16	3.20	1.54	1-1/16	15,000
9-12 X44HBMP7	9/16	3/4	3.98	2.19	1-3/8	15,000
12-9 X44HBMP7	3/4	9/16	3.15	1.35	1-1/4	15,000
12-12 X44HBMP7	3/4	3/4	3.89	1.96	1-3/8	15,000

Dimensions in inches are for reference only, subject to change.

## X44HT7

X44 Male by MPI™ Tube Stub

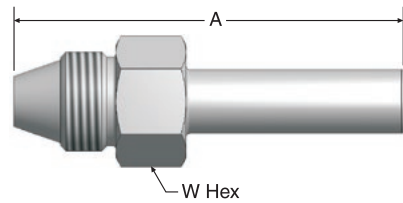

Parker Part No.	Inches				Working Pressure (PSIG)
	X44 Adapter	MPI™ Size	A	W Th'k	
9-9 X44HT7	9/16	9/16	3.60	1	15,000
9-12 X44HT7	9/16	3/4	3.95	1	15,000
12-9 X44HT7	3/4	9/16	3.74	1-1/4	15,000
12-12 X44HT7	3/4	3/4	4.09	1-1/4	15,000

Dimensions in inches are for reference only, subject to change.

## M40HX44

Type "M" Male by X44 Male

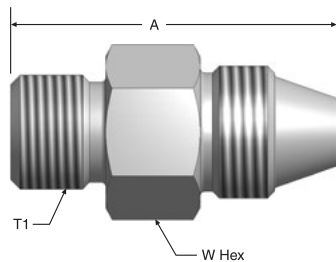

Parker Part No.	Inches					Working Pressure (PSIG)
	Hose* Adapter	X44 Adapter	T1 "M" Thread	A	W Th'k	
6-9 M40HX44	-6	9/16	9/16 - 18 UNF	1.79	1	15,000
6-12 M40HX44	-6	3/4	9/16 - 18 UNF	2.06	1-1/4	15,000
8-9 M40HX44	-8	9/16	3/4 - 16 UNF	1.99	1	15,000
8-12 M40HX44	-8	3/4	3/4 - 16 UNF	2.18	1-1/4	15,000
11-9 M40HX44	-11	9/16	1 - 12 UNF	2.04	1-1/16	15,000
11-12 M40HX44	-11	3/4	1 - 12 UNF	2.18	1-1/4	15,000

Dimensions in inches are for reference only, subject to change.  
Adapts to Type "M" Swivel Hose Connection

## RBMP7

MPI™ to  
Male Run NPT Tee

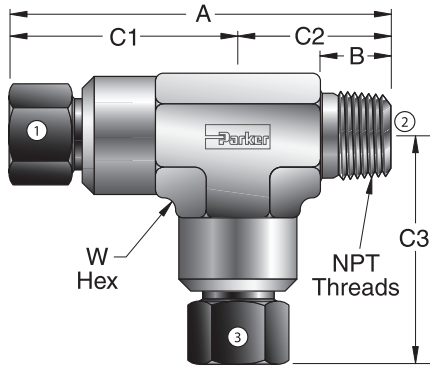

Parker Part No.	MPI™ Size #1	NPT Thread #2	MPI™ Size #3	Inches						Working Pressure (PSIG)
				A	C1	C2	C3	B	W Hex	
4-4-4 RBMP7	1/4	1/4 - 18	1/4	2.76	1.63	1.13	1.63	.57	3/4	15,000
4-4-6 RBMP7	1/4	1/4 - 18	3/8	2.85	1.63	1.23	1.86	.57	7/8	12,500
4-6-4 RBMP7	1/4	3/8 - 18	1/4	2.76	1.63	1.13	1.63	.57	3/4	12,000
4-6-6 RBMP7	1/4	3/8 - 18	3/8	2.85	1.63	1.23	1.86	.57	7/8	12,000
6-4-4 RBMP7	3/8	1/4 - 18	1/4	3.09	1.86	1.23	1.63	.57	7/8	12,500
6-4-6 RBMP7	3/8	1/4 - 18	3/8	3.09	1.86	1.23	1.86	.57	7/8	12,500
6-6-4 RBMP7	3/8	3/8 - 18	1/4	3.09	1.86	1.23	1.63	.57	7/8	12,000
6-6-6 RBMP7	3/8	3/8 - 18	3/8	3.09	1.86	1.23	1.86	.57	7/8	12,000

Dimensions in inches are for reference only, subject to change.

## SBMP7

MPI™ to  
Male Branch NPT Tee

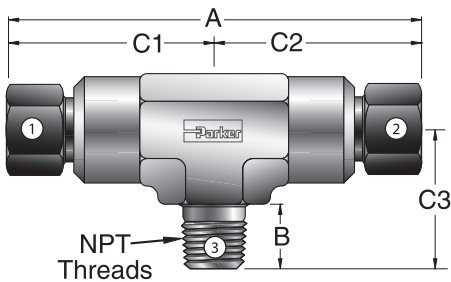

Parker Part No.	MPI™ Size #1	MPI™ Size #2	NPT Thread #3	Inches						Working Pressure (PSIG)
				A	C1	C2	C3	B	W Hex	
4-4-4 SBMP7	1/4	1/4	1/4-18	3.25	1.63	1.63	1.13	.57	3/4	15,000
4-4-6 SBMP7	1/4	1/4	3/8-18	3.25	1.63	1.63	1.13	.57	3/4	12,000
6-6-4 SBMP7	3/8	3/8	1/4-18	3.72	1.86	1.86	1.23	.57	7/8	12,500
6-6-6 SBMP7	3/8	3/8	3/8-18	3.72	1.86	1.86	1.23	.57	7/8	12,000

Dimensions in inches are for reference only, subject to change.

MPI™  
Fittings

## OBMP7

MPI™ to NPT  
Female Branch Tee

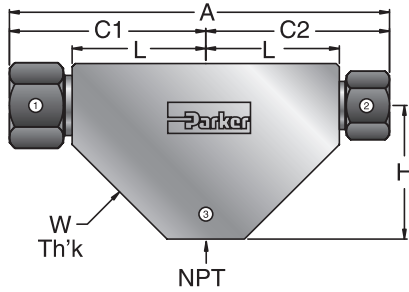

Parker Part No.	Inches								Working Pressure (PSIG)
	MPI™ Size #1	MPI™ Size #2	NPT Thread #3	A	C1	C2	C3	W Th'k	
4-4-4 OBMP7	1/4	1/4	1/4 - 18	3.47	1.74	1.74	1.24	3/4	15,000
6-6-4 OBMP7	3/8	3/8	1/4 - 18	3.72	1.86	1.86	1.24	3/4	15,000
6-6-8 OBMP7	3/8	3/8	1/2 - 14	3.88	1.94	1.94	1.54	1-3/8	15,000
8-8-8 OBMP7	1/2	1/2	1/2 - 14	4.45	2.22	2.22	1.94	1-3/8	15,000
9-9-8 OBMP7	9/16	9/16	1/2 - 14	4.57	2.29	2.29	1.94	1-3/8	15,000
12-12-8 OBMP7	3/4	3/4	1/2 - 14	5.64	2.82	2.82	1.94	1-3/8	15,000

Dimensions in inches are for reference only, subject to change.

Note: Body shape may vary with size/configuration. Consult factory for size-specific drawing.

## KBMP7

MPI™ Union Cross

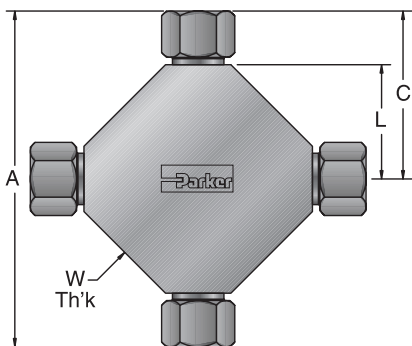

Parker Part No.	MPI™ Size	Inches				Working Pressure (PSIG)
		A	C	L	W Th'k	
4 KBMP7	1/4	3.06	1.53	1.03	5/8	15,000
6 KBMP7	3/8	3.72	1.86	1.24	3/4	15,000
8 KBMP7	1/2	4.45	2.22	1.54	1	15,000
9 KBMP7	9/16	4.57	2.29	1.54	1	15,000
10 KBMP7	5/8	5.00	2.50	1.75	1-3/16	15,000
12 KBMP7	3/8	5.64	2.82	1.94	1-3/8	15,000

Dimensions in inches are for reference only, subject to change.

Note: Body shape may vary with size/configuration. Consult factory for size-specific drawing.

## FNMP7

MPI™ Plug, Assembly

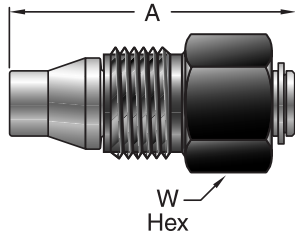

Parker Part No.	Inches			Working Pressure (PSIG)
	MPI™ Size	A	W Hex	
4 FNMP7	1/4	1.41	9/16	15,000
6 FNMP7	3/8	1.65	11/16	15,000
8 FNMP7	1/2	1.94	15/16	15,000
9 FNMP7	9/16	2.00	1	15,000
12 FNMP7	3/4	2.35	1-1/4	15,000
16 FNMP7	1	2.96	1-1/2	12,500

Assemble 1/4 to 1/2 turn from finger tight.  
Dimensions in inches are for reference only, subject to change.

## PNBMP7

MPI™ Cap

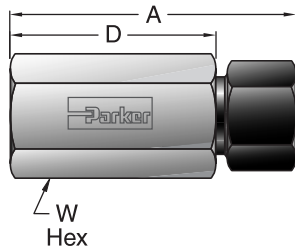

Parker Part No.	Inches				Working Pressure (PSIG)
	MPI™ Size	A	D	W Hex	
4 PNMP7	1/4	1.69	1.19	5/8	15,000
6 PNMP7	3/8	2.12	1.49	3/4	15,000
8 PNMP7	1/2	2.62	1.93	1	15,000
9 PNMP7	9/16	2.75	2.00	1-1/16	15,000
10 PNMP7	3/4	2.86	2.11	1-3/16	15,000
12 PNMP7	3/4	3.53	2.64	1-3/8	15,000
16 PNMP7	1	4.44	3.31	1-3/4	12,500

Dimensions in inches are for reference only, subject to change.

## FNM7

MPI™ Plug, Solid

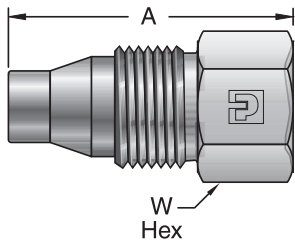

Parker Part No.	Inches			Working Pressure (PSIG)
	MPI™ Size	A	W Hex	
4 FNM7	1/4	1.26	9/16	15,000
6 FNM7	3/8	1.49	11/16	15,000
8 FNM7	1/2	1.76	15/16	15,000
9 FNM7	9/16	1.82	1	15,000
12 FNM7	3/4	2.17	1-1/4	15,000

Assemble 1/4 to 1/2 turn from finger tight and lubricate threads and taper before each remake.  
Dimensions in inches are for reference only, subject to change.

MPI™  
Fittings

## BMP7

MPI™ Nut

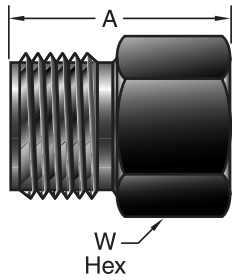

Parker Part No.	Inches		
	MPI™ Size	A	W Hex
4 BMP7	1/4	0.81	9/16
6 BMP7	3/8	0.92	11/16
8 BMP7	1/2	0.97	15/16
9 BMP7	9/16	1.03	1
10 BMP7	5/8	1.13	1-1/16
12 BMP7	3/4	1.34	1-1/4
16 FNMP7	1	1.74	1-1/2

Dimensions in inches are for reference only, subject to change.

## MPFF

MPI™ Front Ferrule

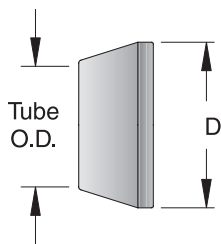

Parker Part No.	Inches	
	Tube O.D.	Ferrule O.D.
4 MPFF	1/4	0.40
6 MPFF	3/8	0.52
8 MPFF	1/2	0.72
9 MPFF	9/16	0.78
10 MPFF	5/8	0.84
12 MPFF	3/4	0.99
16 BMP7	1	1.30

Dimensions in inches are for reference only, subject to change.

## MPBF

MPI™ Back Ferrule

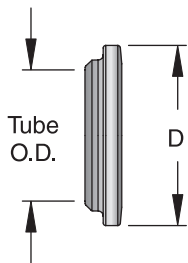

Parker Part No.	Inches	
	Tube O.D.	Ferrule O.D.
4 MPBF	1/4	0.40
6 MPBF	3/8	0.52
8 MPBF	1/2	0.72
9 MPBF	9/16	0.78
10 MPBF	3/4	0.84
12 MPBF	3/4	0.99
16 MPBF	1	1.30

Dimensions in inches are for reference only, subject to change.



## Medium Pressure Valves

### MAN Series Valves

Parker MAN series valves are designed for multi-turn control of media regulation and shutoff up to 15,000 psi. Additional packing materials are available for application temperatures from -100°F to +600°F. Standard critical service design features, such as the packing below the thread and the non-rotating lower stem ensure longer valve life in rugged applications.

### Medium Pressure Valve Connection Types

Valve Connection Type	Description	Drawing
<b>F</b>	Female NPT To 15,000 PSI	
<b>MP7</b>	Parker MPI™ (Medium Pressure Inverted) To 15,000 PSI	

### Material of Construction

Item#	Description	Material
1	Low Friction Packing Gland	Ampco 45
2	Panel Mount Option	316 SS
3	Anti-Extrusion Backup Rings	Ampco 45
4	Valve Body	316 SS
5	Stem Tip	316 SS
6	Metal to Metal Seating	316 SS
7	Adjustable Packing Bellows	PTFE
8	Non-Rotating Stem	316 SS
9	Locking Device	302 SS
10	Powder Coated Handle	316 SS
11	Stem Sleeve	304 SS
12	Hex Nuts	300 Series SS

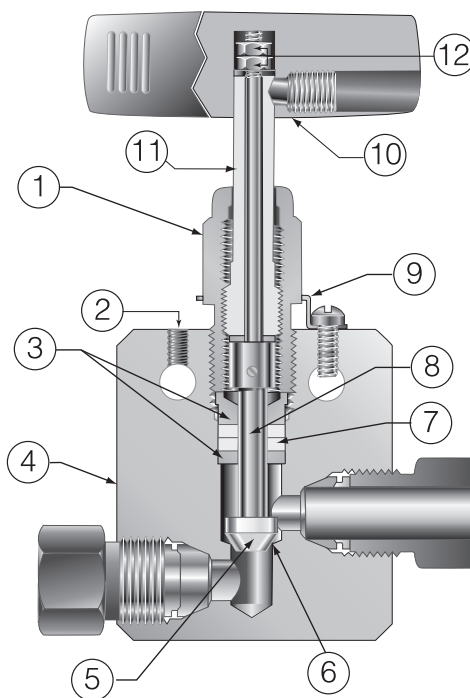

### Panel Hole Sizes

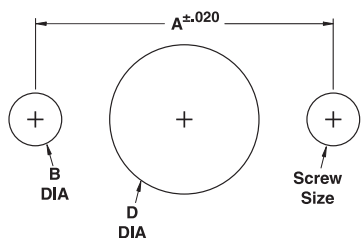

Medium Pressure Needle Valve Panel Mount

Valve Size	Inches			
	A	B	Screw Size	D
4 & 6	1.25	.219	10 - 24	.75
8 & 9	1.375	.219	10 - 24	1.00
12	1.75	.219	10 - 24	1.12
16	2.50	.219	10 - 24	1.62

## Two Way Inline Valves

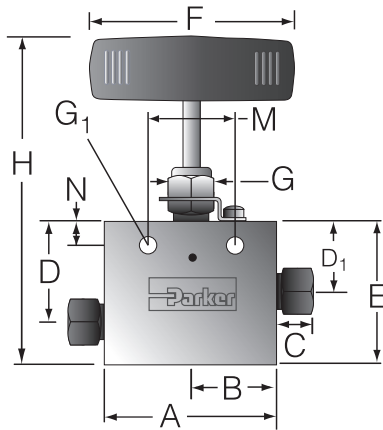

**Notes:**  
 G = Packing gland mounting hole drill size  
 G1 = Bracket mounting hole size  
 H = Dimension with stem in closed position  
 P = Block thickness  
 Panel mounting drill size: 0.22" all valves

Parker Part No.	Orifice	Inches												
		A	B	C	D	D1	E	F	G	G1	H	M	N	P
4MP7-MANLB-T-SS	.125	2.50	1.25	0.50	1.63	1.19	2.13	3.00	0.75	0.22	4.59	1.25	0.38	1.00
6MP7-MANLB-T-SS	.219	2.50	1.25	0.63	1.63	1.19	2.13	3.00	0.75	0.22	4.58	1.25	0.38	1.00
8MP7-MANLB-T-SS	.312	3.00	1.50	0.69	2.38	1.75	3.00	4.00	1.00	0.34	5.99	1.38	0.50	1.38
9MP7-MANLB-T-SS	.312	3.00	1.50	0.75	2.38	1.75	3.00	4.00	1.00	0.34	5.99	1.38	0.50	1.38
12MP7-MANLB-T-SS	.438	4.12	2.06	0.88	3.00	2.25	3.75	10.35	1.12	0.44	6.97	1.75	0.63	1.75
16MP7-MANLB-T-SS	.562	4.75	2.38	1.13	3.75	2.81	4.75	10.35	1.62	0.56	8.83	2.50	1.13	2.00

Dimensions in inches are for reference only, subject to change.

## Two Way Inline Valves: Female NPT

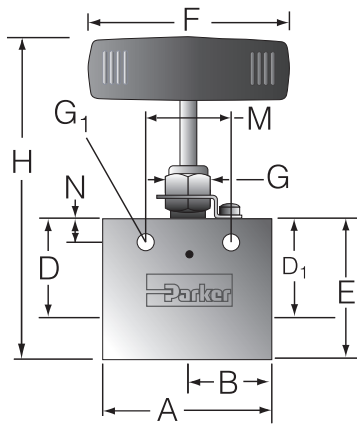

**Notes:**  
 G = Packing gland mounting hole drill size  
 G1 = Bracket mounting hole size  
 H = Dimension with stem in closed position  
 P = Block thickness  
 Panel mounting drill size: 0.22" all valves

Parker Part No.	Orifice	Inches												
		A	B	C	D	D1	E	F	G	G1	H	M	N	P
2F-MANLB-T-SS	.078	1.50	0.75	-	0.81	0.56	1.13	1.75	0.56	0.16	2.41	0.90	0.20	0.62
4F-MANLB-T-SS	.203	2.00	1.00	-	1.41	1.41	2.00	3.00	0.75	0.22	4.46	1.25	0.38	0.75
6F-MANLB-T-SS	.219	2.50	1.25	-	1.41	1.41	2.00	3.00	0.75	0.22	4.45	1.25	0.38	1.00
8F-MANLB-T-SS	.312	3.00	1.50	-	2.06	2.06	2.88	4.00	1.00	0.34	5.94	1.38	0.50	1.38
12F-MANLB-T-SS	.437	3.50	1.75	-	2.63	2.63	3.75	10.35	1.12	0.44	6.97	1.75	0.62	1.75
16F-MANLB-T-SS	.562	4.12	2.06	-	3.31	3.31	4.62	10.35	1.62	0.56	8.70	2.50	1.13	1.75

Dimensions in inches are for reference only, subject to change.

## Two Way Angle Valves

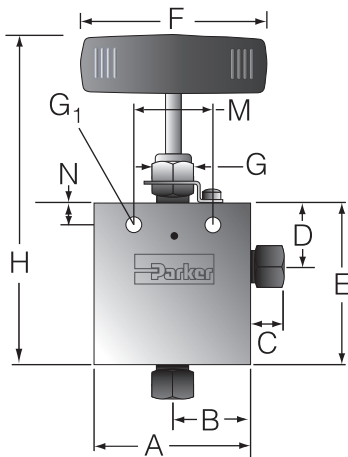

**Notes:**

- G = Packing gland mounting hole drill size
- G1 = Bracket mounting hole size
- H = Dimension with stem in closed position
- P = Block thickness
- Panel mounting drill size: 0.22" all valves

Parker Part No.	Orifice	Inches											
		A	B	C	D	E	F	G	G1	H	M	N	P
4MP7-MANAB-T-SS	.125	2.50	1.25	0.50	1.19	2.57	3.00	0.75	0.22	5.03	1.25	0.38	1.00
6MP7-MANAB-T-SS	.219	2.50	1.25	0.63	1.19	2.57	3.00	0.75	0.22	5.02	1.25	0.38	1.00
8MP7-MANAB-T-SS	.312	3.00	1.50	0.69	1.75	3.58	4.00	1.00	0.34	6.57	1.38	0.50	1.38
9MP7-MANAB-T-SS	.312	3.00	1.50	0.75	1.75	3.58	4.00	1.00	0.34	6.57	1.38	0.50	1.38
12MP7-MANAB-T-SS	.438	4.12	2.06	0.88	2.25	4.25	10.35	1.12	0.44	7.47	1.75	0.63	1.75
16MP7-MANAB-T-SS	.562	4.75	2.38	1.13	2.81	5.44	10.35	1.62	0.56	9.52	2.50	1.13	2.00

Dimensions in inches are for reference only, subject to change.

MPI™ Medium Pressure Valves

## Two Way Angle Valves: Female NPT

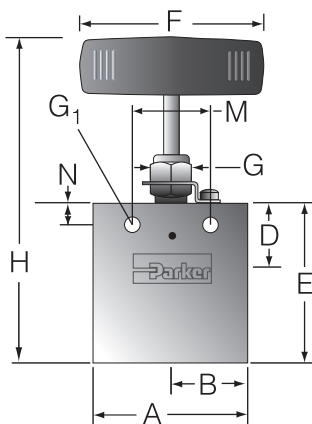

**Notes:**

- G = Packing gland mounting hole drill size
- G1 = Bracket mounting hole size
- H = Dimension with stem in closed position
- P = Block thickness
- Panel mounting drill size: 0.22" all valves

Parker Part No.	Orifice	Inches											
		A	B	C	D	E	F	G	G1	H	M	N	P
2F-MANAB-T-SS	.078	1.50	0.75	-	0.56	1.38	1.75	0.56	0.16	2.66	0.90	0.20	0.62
4F-MANAB-T-SS	.203	2.00	1.00	-	1.41	2.44	3.00	0.75	0.22	4.90	1.25	0.38	0.75
6F-MANAB-T-SS	.219	2.50	1.25	-	1.41	2.44	3.00	0.75	0.22	4.89	1.25	0.38	1.00
8F-MANAB-T-SS	.312	3.00	1.50	-	2.06	3.38	4.00	1.00	0.34	6.44	1.38	0.50	1.38
12F-MANAB-T-SS	.437	3.50	1.75	-	2.63	4.25	10.35	1.12	0.44	7.47	1.75	0.62	1.75
16F-MANAB-T-SS	.562	4.12	2.06	-	3.31	5.12	10.35	1.62	0.56	9.20	2.50	1.13	1.75

Dimensions in inches are for reference only, subject to change.

## Three Way/Two Pressure Connections

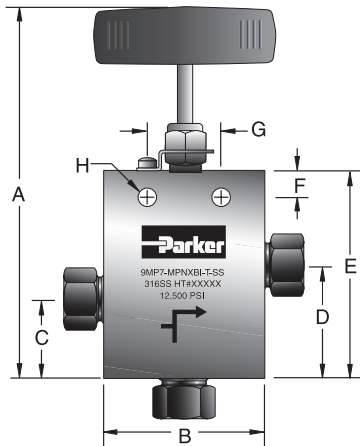

### Panel Hole Sizes

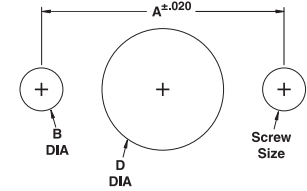

Valve Size	Inches (mm)			
	A	B	Screw Size	D
4 & 6	1.25 (31.75)	.219 (5.56)	10 - 32	0.75 (19.05)
8 & 9	1.375 (34.92)	.219 (5.56)	10 - 32	1.00 (25.40)
12	1.75 (44.45)	.219 (5.56)	10 - 32	1.19 (30.22)
16	2.50 (63.50)	.219 (5.56)	10 - 32	1.63 (41.40)

Dimensions in inches are for reference only, subject to change.

Tubing	Parker Part No.	PSI	Connection	Inches									
				Orifice	A	B	C	D	E	F	G	H	Th'k
1/4" O.D.	4MP7-MANXBI-T-SS	15,000	1/4" MPI	0.125	5.21	2.50	1.21	1.65	2.84	0.38	1.25	0.22	1.00
3/8" O.D.	6MP7-MANXBI-T-SS	15,000	3/8" MPI	0.203	5.21	2.50	1.21	1.65	2.84	0.38	1.25	0.22	1.00
1/2" O.D.	8MP7-MANXBI-T-SS	15,000	1/2" MPI	0.313	7.09	3.00	1.50	2.12	3.88	0.50	1.38	0.34	1.38
9/16" O.D.	9MP7-MANXBI-T-SS	15,000	9/16" MPI	0.313	7.09	3.00	1.50	2.12	3.88	0.50	1.38	0.34	1.38
3/4" O.D.	12MP7-MANXBI-T-SS	15,000	3/4" MPI	0.438	7.88	3.00	2.63	2.38	4.63	0.63	1.75	0.44	1.38
3/4" O.D.	12MP7-MANXBHI-T-SS	10,000	3/4" MPI	0.516	7.88	3.00	2.63	2.38	4.63	0.63	1.75	0.44	1.38
1.0" O.D.	16MP7-MANXBI-T-SS	12,500	1" MPI	0.563	9.75	4.13	2.13	3.06	5.88	1.13	2.50	0.56	1.75
1.0" O.D.	16MP7-MANXBI-T-SS	10,000	1" MPI	0.688	9.75	4.13	2.13	3.06	5.88	1.13	2.50	0.56	1.75

Dimensions in inches are for reference only, subject to change.

## Three Way/One Pressure Connections

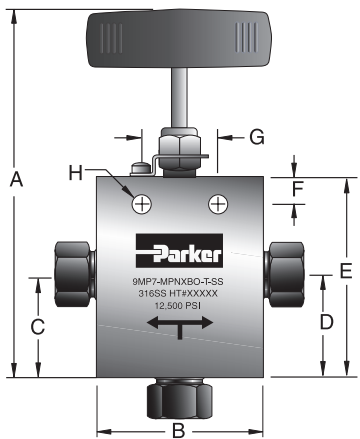

### Panel Hole Sizes

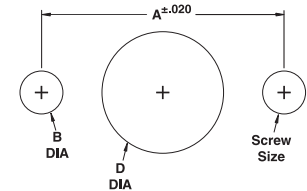

Valve Size	Inches (mm)			
	A	B	Screw Size	D
4 & 6	1.25 (31.75)	.219 (5.56)	10 - 32	0.75 (19.05)
8 & 9	1.375 (34.92)	.219 (5.56)	10 - 32	1.00 (25.40)
12	1.75 (44.45)	.219 (5.56)	10 - 32	1.19 (30.22)
16	2.50 (63.50)	.219 (5.56)	10 - 32	1.63 (41.40)

Dimensions in inches are for reference only, subject to change.

Tubing	Parker Part No.	PSI	Connection	Inches									
				Orifice	A	B	C	D	E	F	G	H	Th'k
1/4" O.D.	4MP7-MANXB0-T-SS	15,000	1/4" MPI	0.125	5.02	2.50	1.38	1.38	2.57	0.38	1.25	0.22	1.00
3/8" O.D.	6MP7-MANXB0-T-SS	15,000	3/8" MPI	0.203	5.02	2.50	1.38	1.38	2.57	0.38	1.25	0.22	1.00
1/2" O.D.	8MP7-MANXB0-T-SS	15,000	1/2" MPI	0.313	6.84	3.00	1.88	1.88	3.63	0.50	1.38	0.34	1.38
9/16" O.D.	9MP7-MANXB0-T-SS	15,000	9/16" MPI	0.313	6.84	3.00	1.88	1.88	3.63	0.50	1.38	0.34	1.38
3/4" O.D.	12MP7-MANXB0-T-SS	15,000	3/4" MPI	0.438	7.50	3.00	2.00	2.00	4.25	0.63	1.75	0.44	1.38
3/4" O.D.	12MP7-MANXB0H-T-SS	10,000	3/4" MPI	0.516	7.50	3.00	2.00	2.00	4.25	0.63	1.75	0.44	1.38
1.0" O.D.	16MP7-MANXB0-T-SS	12,500	1" MPI	0.563	9.38	4.13	2.63	2.63	5.44	1.13	2.50	0.56	1.75
1.0" O.D.	16MP7-MANXB0-T-SS	10,000	1" MPI	0.688	9.38	4.13	2.63	2.63	5.44	1.13	2.50	0.56	1.75

Dimensions in inches are for reference only, subject to change.

## Three Way/Two Stem Connections

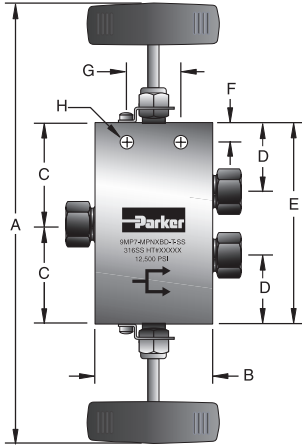

Panel Hole Sizes

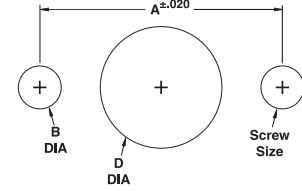

Valve Size	Inches (mm)			
	A	B	Screw Size	D
4 & 6	1.25 (31.75)	.219 (5.56)	10 - 32	0.75 (19.05)
8 & 9	1.375 (34.92)	.219 (5.56)	10 - 32	1.00 (25.40)
12	1.75 (44.45)	.219 (5.56)	10 - 32	1.19 (30.22)
16	2.50 (63.50)	.219 (5.56)	10 - 32	1.63 (41.40)

Dimensions in inches are for reference only, subject to change.

Tubing	Parker Part No.	PSI	Connection	Inches									
				Orifice	A	B	C	D	E	F	G	H	Th'k
1/4" O.D.	4MP7-MANXBD-T-SS	15,000	1/4" MPI	0.125	5.21	2.50	1.70	1.19	3.38	0.38	1.25	0.22	1.00
3/8" O.D.	6MP7-MANXBD-T-SS	15,000	3/8" MPI	0.203	5.21	2.50	1.70	1.19	3.38	0.38	1.25	0.22	1.00
1/2" O.D.	8MP7-MANXBD-T-SS	15,000	1/2" MPI	0.313	8.38	3.00	2.56	1.75	5.13	0.50	1.38	0.34	1.38
9/16" O.D.	9MP7-MANXBBDI-T-SS	15,000	9/16" MPI	0.313	8.38	3.00	2.56	1.75	5.13	0.50	1.38	0.34	1.38
3/4" O.D.	12MP7-MANXBD-T-SS	15,000	3/4" MPI	0.438	9.75	3.00	3.25	2.25	6.50	0.63	1.75	0.44	1.38
3/4" O.D.	12MP7-MANXBBDH-T-SS	10,000	3/4" MPI	0.516	9.75	3.00	3.25	2.25	6.50	0.63	1.75	0.44	1.38
1.0" O.D.	16MP7-MANXBD-T-SS	12,500	1" MPI	0.563	12.19	4.13	4.13	2.81	8.25	1.13	2.50	0.56	1.75
1.0" O.D.	16MP7-MANXBD-T-SS	10,000	1" MPI	0.688	12.19	4.13	4.13	2.81	8.25	1.13	2.50	0.56	1.75

Dimensions in inches are for reference only, subject to change.

MPI™ Medium Pressure Valves

## Two Way Angle Valves (Replaceable Seat)

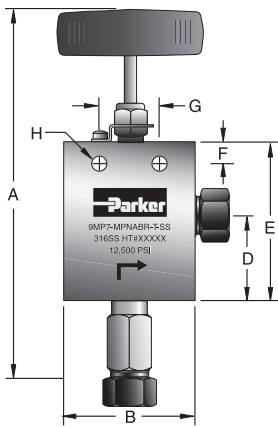

Panel Hole Sizes

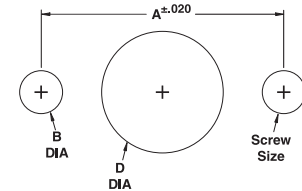

Valve Size	Inches (mm)			
	A	B	Screw Size	D
4 & 6	1.25 (31.75)	.219 (5.56)	10 - 32	0.75 (19.05)
8 & 9	1.375 (34.92)	.219 (5.56)	10 - 32	1.00 (25.40)
12	1.75 (44.45)	.219 (5.56)	10 - 32	1.19 (30.22)
16	2.50 (63.50)	.219 (5.56)	10 - 32	1.63 (41.40)

Dimensions in inches are for reference only, subject to change.

Tubing	Parker Part No.	PSI	Connection	Inches									
				Orifice	A	B	C	D	E	F	G	H	Th'k
1/4" O.D.	4MP7-MANABR-T-SS	15,000	1/4" MPI	0.125	5.87	2.50	-	1.38	2.57	0.38	1.25	0.22	1.00
3/8" O.D.	6MP7-MANABR-T-SS	15,000	3/8" MPI	0.203	5.87	2.50	-	1.38	2.57	0.38	1.25	0.22	1.00
1/2" O.D.	8MP7-MANABR-T-SS	15,000	1/2" MPI	0.313	8.25	3.00	-	2.00	3.63	0.50	1.38	0.34	1.38
9/16" O.D.	9MP7-MANABR-T-SS	15,000	9/16" MPI	0.313	8.25	3.00	-	2.00	3.63	0.50	1.38	0.34	1.38
3/4" O.D.	12MP7-MANABR-T-SS	15,000	3/4" MPI	0.438	8.88	3.00	-	2.00	4.25	0.63	1.75	0.44	1.38
3/4" O.D.	12MP7-MANABRH-T-SS	10,000	3/4" MPI	0.516	8.88	3.00	-	2.00	4.25	0.63	1.75	0.44	1.38
1.0" O.D.	16MP7-MANABR-T-SS	12,500	1" MPI	0.563	11.13	4.13	-	2.56	5.44	1.13	2.50	0.56	1.75
1.0" O.D.	16MP7-MANABR-T-SS	10,000	1" MPI	0.688	11.13	4.13	-	2.56	5.44	1.13	2.50	0.56	1.75

Dimensions in inches are for reference only, subject to change.



## How to Order MAN Series Valves

The correct part number is easily derived from the following example and ordering chart. The eight product characteristics required are coded as shown in the chart.

The following example describes an MAN Series needle valve with 1/4" MPI connections, 2 way angle flow path, blunt stem, PTFE packing and a stainless steel body and the option for over critical service.

Typical part number example: **4MP7-MANAB-T-SS** (part number is created based on customer selection of product parameters, see below for example)

4	MP7	-	MAN	A	B		-	T	-	SS
Inlet/Outlet Connection Size	Connection Type		Valve Series	Valve Type	Stem Type	High Flow		Packing Material		Body Material
<b>2*</b> = 1/8" <b>4</b> = 1/4" <b>6</b> = 3/8" <b>8</b> = 1/2" <b>9**</b> = 9/16" <b>12</b> = 3/4" <b>16</b> = 1"	<b>F</b> = Female Pipe  <b>MP7</b> = Parker MPI™		<b>MAN</b>	<b>L</b> = 2 Way Inline  <b>A</b> = 2 Way Angle  <b>X***I</b> = 3 Way, 2 Pressure Connections  <b>X***D</b> = 3 Way, 2 Stem Connection  <b>A***R</b> = 2 Way Angle Valve (replaceable seat)  <b>X***O</b> = 3 Way, 1 Pressure Connection	<b>B</b> = Blunt  <b>R</b> = Regulating	<b>Blank</b> = Standard Flow  <b>H</b> = High Flow		<b>T</b> = PTFE  <b>G<sup>1</sup></b> = Grafoil®		<b>SS</b> = Stainless Steel  <b>2507</b> = Super Duplex
* Female Pipe only ** MP7 only				*** Needle Type inserted here						

<sup>1</sup> Maximum working temperature is 600°F. Please see page 9 for pressure derating factor calculation.

Grafoil® is a registered trademark of GrafTech International Holdings, Inc.

## Bleed Valves

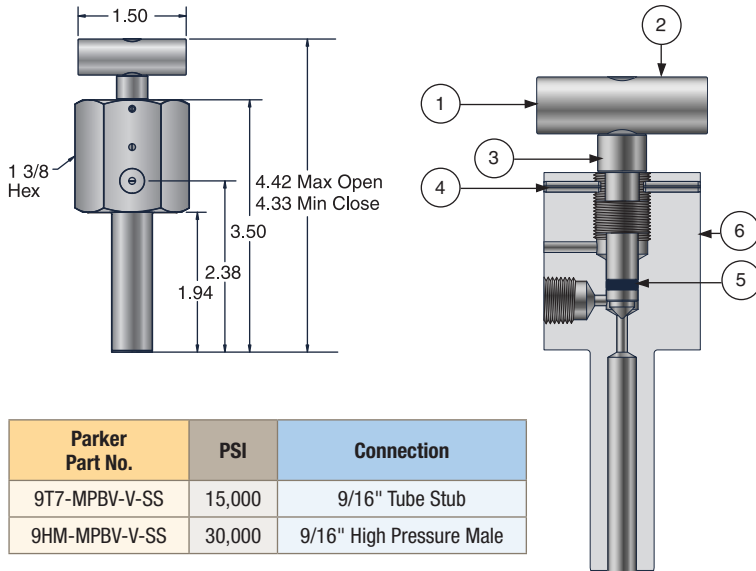

Parker Part No.	PSI	Connection
9T7-MPBV-V-SS	15,000	9/16" Tube Stub
9HM-MPBV-V-SS	30,000	9/16" High Pressure Male

### Material of Construction

Item#	Qty	Description	Material
1	1	Soc Set Screw	300 Ser. SS
2	1	Handle	Aluminum
3	1	Stem	17-4PH-H900
4	2	Rolling Pin	420 SS
5	1	O-ring	Fluorocarbon Rubber*
6	1	Body	316 SS

#### \* Optional Seal Materials

<b>KZ</b>	Highly Fluoinated Fluorcarbon Rubber
<b>BN</b>	Nitrile Rubber
<b>EPR</b>	Ethylene Propylene Rubber

Example: 9T7-MPBV-KZ-SS

## Gauge Valve

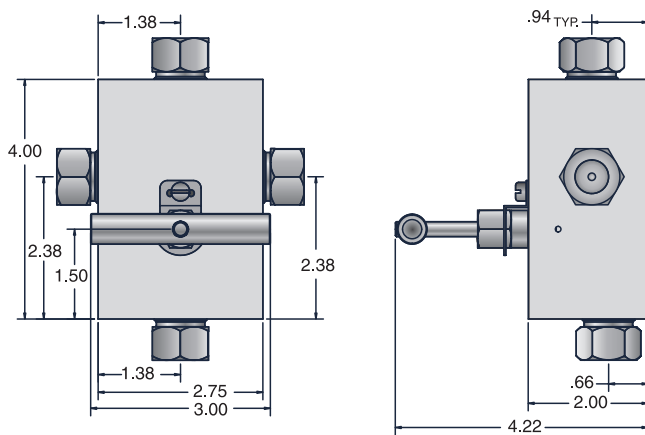

Parker Part No.	PSI	Connection
9MP7-MPGV-V-SS	15,000	9/16" MPI™
9HF-MPGV-V-SS	30,000	9/16" High Pressure Female

### Material of Construction

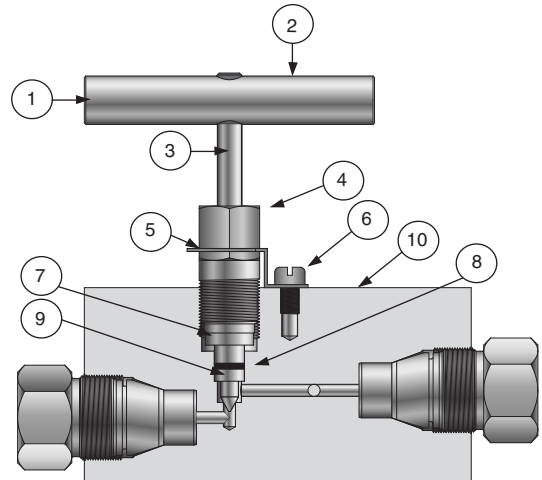

Item#	Qty	Description	Material
1	1	Soc Set Screw	Steel
2	1	Handle	Aluminum
3	1	Stem Assembly	17-4PH
4	1	Packing Gland	316 SS
5	1	Locking Device	300 Ser. SS
6	1	10-32 x 1/4 Fill Hd. Screw	300 Ser. SS
7	1	Top Packing Washer	416 SS
8	1	Packing	Fluorocarbon Rubber
9	1	Bottom Packing Washer	316 SS
10	1	Body	316 SS





## MAB Series Valves

Parker MAB series manually, pneumatically and electrically actuated two-way and three-way ball valves are designed for 1/4 and 1/2 turn media shutoff or switching applications up to 15,000 psi. Our trunion style ball design and spring loaded seats make the MAB series ideal for severe service applications. The end connector design enables a variety of end connections and combinations for specific customer applications.

## 2 Way Ball Valves

Orifice Size	Part Number	MAWP PSI	Connection	Inches		
				Minimum Valve Orifice	Cv	Overall Length
1/4"	2F-MAB4LPK-V-SSP	15,000	1/8" NPT	0.250	1.51	4.19
	4F-MAB4LPK-V-SSP	15,000	1/4" NPT	0.250	1.51	4.19
	4MP7-MAB4LPK-V-SSP	15,000	1/4" MPI	0.125	0.42	5.19
	6F-MAB4LPK-V-SSP	15,000	3/8" NPT	0.250	1.51	4.19
	6MP7-MAB4LPK-V-SSP	15,000	3/8" MPI	0.250	1.51	5.45
	8MP7-MAB4LPK-V-SSP	15,000	1/2" MPI	0.250	1.51	6.72
	9MP7-MAB4LPK-V-SSP	15,000	9/16" MPI	0.250	1.51	6.84
3/8"	8F-MAB6LPK-V-SSP	15,000	1/2" NPT	0.375	5.20	5.53
	8MP7-MAB6LPK-V-SSP	15,000	1/2" MPI	0.312	3.90	7.65
	9MP7-MAB6LPK-V-SSP	15,000	9/16" MPI	0.375	5.20	7.77
1/2"	12F-MAB8LPK-V-SSP	10,000	3/4" NPT	0.500	10.20	7.73
	12MP7-MAB8LPK-V-SSP	15,000	3/4" MPI	0.500	10.20	12.61
	16F-MAB8LPK-V-SSP	10,000	1" NPT	0.500	10.20	7.73
	16MP7-MAB8LPK-V-SSP	12,500	1" MPI	0.500	10.20	13.11
3/4"	12F-MAB12LPK-V-SSP	10,000	3/4" NPT	0.750	21.00	9.18
	12MP7-MAB12LPK-V-SSP	15,000	3/4" MPI	0.531	10.20	10.94
	16F-MAB12LPK-V-SSP	10,000	1" NPT	0.750	21.00	9.18
	16MP7-MAB12LPK-V-SSP	12,500	1" MPI	0.688	21.00	11.44

Dimensions in inches are for reference only, subject to change.

## Dimensions

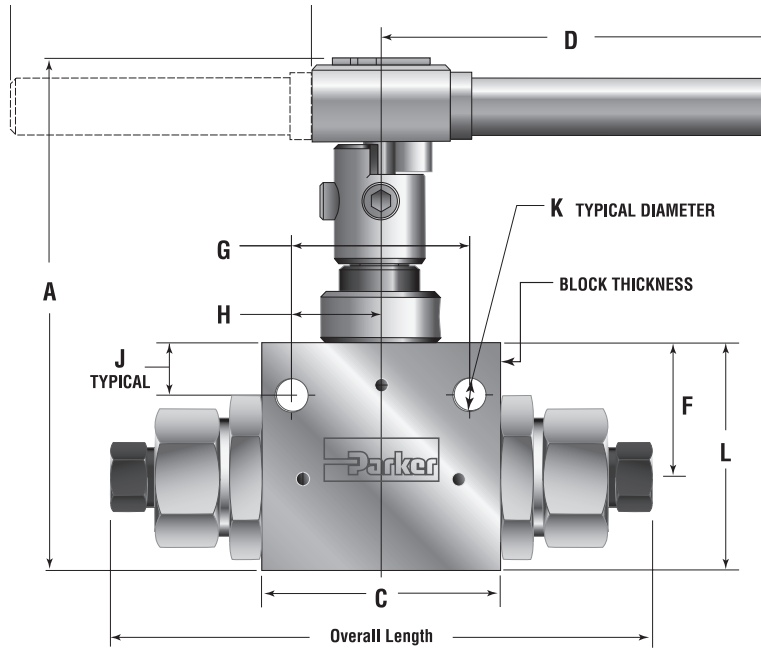

Orifice Size	Inches (mm)										
	A	C	D	E	F	G	H	J	K	L	Block Th'k
1/4"	4.33 (109.99)	2.00 (50.80)	3.37 (85.55)	3.90 (99.02)	1.13 (28.58)	1.50 (38.10)	0.75 (19.05)	0.43 (10.92)	0.28 (7.11)	1.91 (48.41)	1.00 (25.40)
3/8"	4.99 (126.75)	3.00 (76.20)	4.99 (126.82)	5.52 (140.32)	1.38 (34.92)	2.00 (50.80)	1.00 (25.40)	0.41 (10.31)	0.28 (7.11)	2.50 (63.50)	1.38 (34.92)
1/2"	6.43 (163.32)	4.13 (104.78)	5.12 (130.05)	10.24* (260.10)	1.76 (44.70)	3.00 (76.20)	1.50 (38.10)	0.50 (12.70)	0.28 (7.11)	3.55 (90.17)	1.75 (44.45)
3/4"	10.13 (257.30)	4.50 (114.30)	11.00 (279.40)	22.00* (558.80)	2.47 (62.70)	3.25 (82.60)	1.63 (41.40)	0.69 (17.50)	0.41 (10.40)	4.50 (114.30)	3.00 (76.20)

Dimensions in inches are for reference only, subject to change.

## Panel Hole Sizes

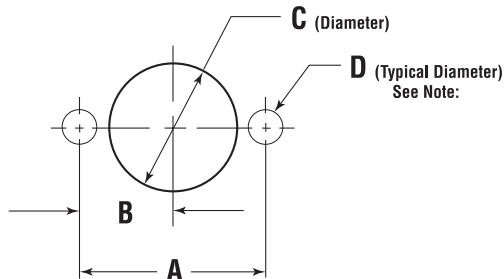

All dimensions are for reference only and are subject to change without notice.

Orifice Size	Inches (mm)				Body Mounting
	A	B	C	D	
1/4"	1.50 (38.10)	0.75 (19.05)	1.06 (26.92)	0.28 (7.11)	1/4" - 20 Thread
3/8"	2.00 (50.80)	1.00 (25.40)	1.50 (38.10)	0.28 (7.11)	
1/2"	3.00 (76.20)	1.50 (38.10)	1.88 (47.63)	0.28 (7.11)	
3/4"	3.25 (82.60)	1.63 (41.40)	2.38 (60.30)	0.44 (11.20)	3/8" - 16 Thread

Dimensions in inches are for reference only, subject to change.



## 3 Way Ball Valves

Orifice Size	Part Number 3 Way 90° Diverter	Part Number 3 Way 180° Selector	MAWP PSI	Connection	Inches				
					Minimum Valve Orifice	Cv	Overall Length	A	M
3/16"	2F-MAB3XPKD-V-SSP	2F-MAB3XPK-V-SSP	15,000	1/8" NPT	0.188	0.50	4.72	5.66	0.97
	4F-MAB3XPKD-V-SSP	4F-MAB3XPK-V-SSP	15,000	1/4" NPT	0.188	0.50	4.72	5.66	0.97
	4MP7-MAB3XPKD-V-SSP	4MP7-MAB3XPK-V-SSP	15,000	1/4" MPI	0.125	0.33	5.72	6.16	5.19
	6F-MAB3XPKD-V-SSP	6F-MAB3XPK-V-SSP	15,000	3/8" NPT	0.188	0.50	4.72	5.66	0.97
	6MP7-MAB3XPKD-V-SSP	6MP7-MAB3XPK-V-SSP	15,000	3/8" MPI	0.188	0.50	5.98	6.27	1.60
	8MP7-MAB3XPKD-V-SSP	8MP7-MAB3XPK-V-SSP	15,000	1/2" MPI	0.188	0.50	7.22	6.92	2.23
	9MP7-MAB3XPKD-V-SSP	9MP7-MAB3XPK-V-SSP	15,000	9/16" MPI	0.188	0.50	7.34	6.98	2.29
3/8"	6MP7-MAB6XPKD-V-SSP	6MP7-MAB6XPK-V-SSP	15,000	3/8" MPI	0.250	1.50	7.54	7.53	2.17
	8F-MAB6XPKD-V-SSP	8F-MAB6XPK-V-SSP	15,000	1/2" NPT	0.328	2.10	5.74	6.55	1.19
	8MP7-MAB6XPKD-V-SSP	8MP7-MAB6XPK-V-SSP	15,000	1/2" MPI	0.312	2.00	7.66	7.59	2.23
	9MP7-MAB6XPKD-V-SSP	9MP7-MAB6XPK-V-SSP	15,000	9/16" MPI	0.328	2.10	7.78	7.65	2.29
1/2"	12F-MAB8XPKD-V-SSP	12F-MAB8XPK-V-SSP	10,000	3/4" NPT	0.500	4.40	7.80	7.81	1.70
	12MP7-MAB8XPKD-V-SSP	12MP7-MAB8XPK-V-SSP	10,000	3/4" MPI	0.500	4.40	12.61	9.23	3.10
	16F-MAB8XPKD-V-SSP	16F-MAB8XPK-V-SSP	10,000	1" NPT	0.500	4.40	7.80	7.81	1.70
	16MP7-MAB8XPKD-V-SSP	16MP7-MAB8XPK-V-SSP	10,000	1" MPI	0.500	4.40	13.11	9.48	3.35

Dimensions in inches are for reference only, subject to change.

MPI™ Medium Pressure Valves

### Material of Construction

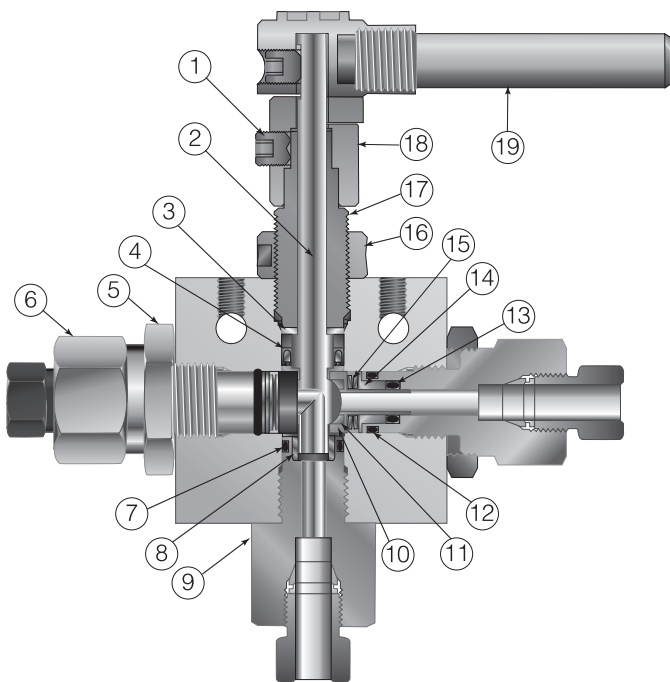

Item#	Description	Material
1	Set Screw	Stainless
2	One Piece Ball and Stem	316 SS
3	Thrust Washer	Ampco 45
4	Spring Energized Seal	Viton
5	Locknut	316 SS
6	Seat Gland	316 CW SS
7	O-ring	Viton
8	Bearing	AMPCO 45
9	Bottom Gland	316 CW SS
10	Seat Retainer	Nitronic 50 HS
11	Carbon Filled Peek Seats	Arlon 1260
12	O-ring	Viton
13	O-ring	Viton
14	Belleville Backup	316 CW SS
15	Belleville Washers	302 SS
16	Locking Body	316 SS
17	Packing Gland	316 CW SS
18	Stopping Device	316 SS
19	Stainless Steel Handle	304 SS

## Dimensions

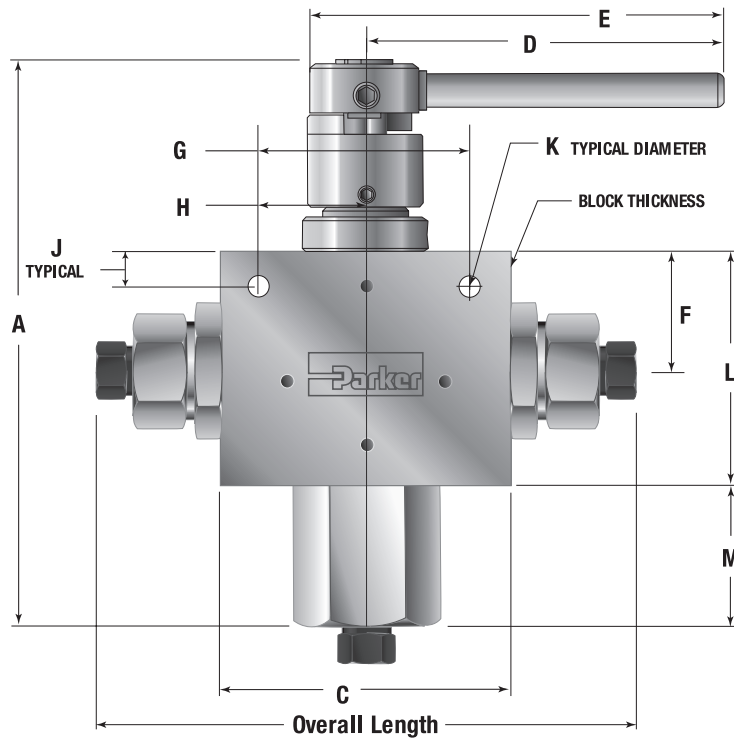

Orifice Size	Inches (mm)									
	C	D	E	F	G	H	J	K	L	Block Th'k
1/4"	2.50 (63.50)	3.37 (85.55)	3.90 (99.02)	1.13 (28.58)	1.50 (38.10)	0.75 (19.05)	0.43 (10.92)	0.28 (7.11)	2.25 (57.15)	1.00 (25.40)
3/8"	3.00 (76.20)	4.99 (126.82)	5.52 (140.32)	1.38 (34.93)	2.00 (50.80)	1.00 (25.40)	0.41 (10.31)	0.28 (7.11)	2.88 (73.03)	1.38 (34.92)
1/2"	4.13 (104.78)	5.12 (130.04)	10.25* (260.35)	1.66 (42.16)	3.00 (76.20)	1.50 (38.10)	0.50 (12.70)	0.28 (7.11)	3.34 (84.94)	1.75 (44.45)

Dimensions in inches are for reference only, subject to change.

MPI™ Medium Pressure Valves

## Panel Hole Sizes

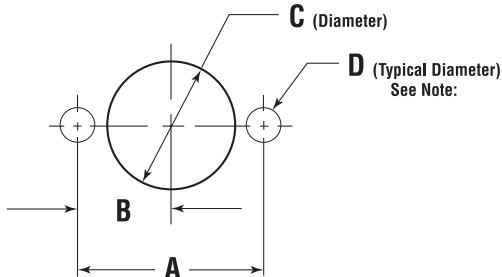

All dimensions are for reference only and are subject to change without notice.

Orifice Size	Inches (mm)				Body Mounting
	A	B	C	D	
1/4"	1.50 (38.10)	0.75 (19.05)	1.06 (26.92)	0.28 (7.11)	1/4" - 20 Thread
3/8"	2.00 (50.80)	1.00 (25.40)	1.50 (38.10)	0.28 (7.11)	
1/2"	3.00 (76.20)	1.50 (38.10)	1.88 (47.63)	0.28 (7.11)	

Dimensions in inches are for reference only, subject to change.



## How to Order MAB Series Valves

The correct part number is easily derived from the following example and ordering chart. The nine product characteristics required are coded as shown in the chart.

The following example describes an MAB Series, three-way diverter ball valve with a .375" orifice, fluorocarbon rubber seals, 1/4" MPI medium pressure inverted connections on all ports and the optional lock out device.

Typical part number example: **4MP7-MA6XPKD-V-SSP-LD** (part number is created based on customer selection of product parameters, see below for example)

4	MP7	-	MAB	6	X	PK	D	-	V	-	SSP	-	LD
Inlet/Outlet Connection Size	Connection Type		Valve Series	Orifice Size	Valve Type	Seat Material	3 Way Valve Type		Seal Material		Body Material		Options
2* = 1/8"	<b>F=</b> Female Pipe		<b>MAB</b>	2 = 3/16" <sup>2</sup>	<b>L=</b> 2 Way	<b>PK=</b> PEEK	<b>Blank=</b> Selector		<b>V***=</b> Fluorocarbon Rubber		<b>SSP=</b> Stainless Steel		<b>LD=</b> Lock Out Device
4 = 1/4"	<b>MP7=</b> Parker MPI™			4 = 1/4" <sup>1</sup>	<b>X=</b> 3 Way		<b>D=</b> Diverter		<b>KZ=</b> Highly Fluorinated Fluorocarbon Rubber		<b>2507P=</b> Super Duplex		
6 = 3/8"				6 = 3/8"					<b>BN=</b> Nitrile Rubber				
8 = 1/2"				8 = 1/2"					<b>EPR=</b> Ethylene Propylene Rubber				
9** = 9/16"				12 = 3/4" <sup>1</sup>									
12 = 3/4"													
16 = 1"													
* Female Pipe only ** MP7 & MF only									*** Standard packing material				

<sup>1</sup> Only Available with 2-Way Valves

<sup>2</sup> Only Available with 3-Way Valves

## How to Order Options

**Lock Out Devices** – add the suffix **-LD** to the end of the part number to specify a factory-installed lock out device.

## Ball Valves: MAB Series Actuators

### Pneumatic and Electric

Parker MAB Series ball valves can be supplied with either pneumatic or electric operators for automated or remote operation.

Pneumatic and electric operators can be supplied with a variety of features and options. Operators are sized for each valve series to provide reliable and trouble free operation. Listed below are the operator features and available options.



## MAB Ball Valve Actuator Features:

### Pneumatic Operators

- Used for remote and automatic operation
- Air-to-open/spring-to-close (FC)
- Air-to-close/spring-to-open (FO)
- Air-to-open and close (double acting) (AD)
- Limit switches or limit switches with visual indicators available
- High temperature option available.
- Stainless steel housing for corrosive applications available.
- Optional solenoid valve available
- Standard anodized aluminum housing
- Optional epoxy coated housing available

### Electric Operators

- Interface with control systems for automated operation and monitoring
- 120 & 220 VAC, 50/60 Hz standard
- 24VDC
- Explosion proof available
- CE mark available

## Applications:

- Laboratories
- Test Stands
- Control Panels
- Chemical Research
- Pilot Plants
- Water Blasting Pumping Units
- High Volume Chemical Injection Skids

## Ball Valves: MAB Series Actuators

Pneumatic and Electric

### Pneumatic Operated Ball Valves

Add the suffix **-FC**, **-FO** or **-AD**<sup>†</sup> to the appropriate valve catalog number for a complete valve assembly.

VALVE SERIES	Dimensions Data - inches (mm)										Minimum Required Air Pressure
	A	B	C	D	E	F	G	H	I	J	
MAB4L-FC/FO	6.85 (173.99)	3.20 (81.28)	2.50 (63.50)	1.25 (31.75)	1.00 (25.40)	0.50 (12.70)	0.28 (7.11)	1.30 (33.02)	2.50 (63.50)	1.88 (47.45)	80 psi (5.51 bar)
MAB6L-FC/FO	7.28 (184.91)	3.86 (98.04)	3.00 (76.20)	1.50 (38.10)	1.50 (38.10)	0.75 (19.05)	0.34 (8.64)	1.59 (40.39)	3.00 (76.20)	2.10 (53.34)	80 psi (5.51 bar)
MAB8L-FC/FO	9.38 (238.25)	4.62 (117.35)	3.00 (76.20)	1.50 (38.10)	2.00 (50.80)	1.00 (25.40)	0.53 (13.46)	2.00 (50.80)	3.00 (76.20)	2.48 (62.99)	80 psi (5.51 bar)
MAB3XD-FC/FO <sup>††</sup>	6.85 (173.99)	3.20 (81.28)	2.50 (63.50)	1.25 (31.75)	1.00 (25.40)	0.50 (12.70)	0.28 (7.11)	1.30 (33.02)	2.50 (63.50)	1.88 (47.75)	80 psi (5.51 bar)
MAB6XD-FC/FO <sup>††</sup>	7.28 (184.91)	3.86 (98.04)	3.00 (76.20)	1.50 (38.10)	1.50 (38.10)	0.75 (19.05)	0.34 (8.64)	1.59 (40.39)	3.00 (76.20)	2.10 (53.34)	80 psi (5.51 bar)
MAB8XD-FC/FO <sup>††</sup>	9.38 (238.25)	4.62 (117.35)	3.00 (76.20)	1.50 (38.10)	2.00 (50.80)	1.00 (25.40)	0.53 (13.46)	2.00 (50.80)	3.00 (76.20)	2.48 (62.99)	80 psi (5.51 bar)

**NOTE:**

- Maximum allowable air pressure is 150 psi (10.34)
- 1/4" NPT female air connection
- FC: Air to open/spring to close
- FO: Air to close/spring to open
- AD: Air to open/air to close (double acting)
- Actuators operating temperature: -10°F to 175°F (-23°C to 79°C)
- High temperature actuator option available, consult factory
- Stainless steel housing actuator models available, consult factory
- Actuators available with limit switches and visual indicators.
- Corrosion resistant anodized aluminum housing.
- Epoxy coated housing available.
- Solenoids available, direct or nipple mount.

<sup>†</sup> AD Actuator not shown consult factory  
<sup>††</sup> MAB3X, MAB6X, & MAB8X Series not shown consult factory

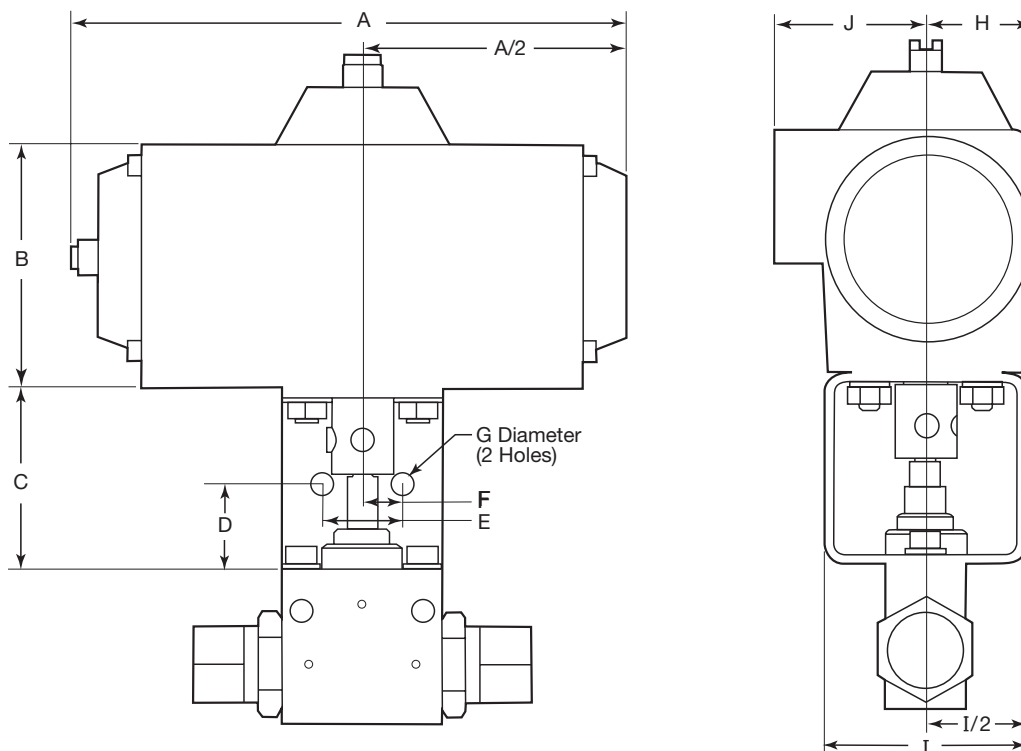



# Ball Valves: MAB Series Actuators

Pneumatic and Electric

## Electric Operated Ball Valves

Add the suffix **-E01**, **-E02** or **-E03** to the appropriate valve catalog number for a complete valve assembly.

VALVE SERIES	Dimensions Data - inches (mm)						VOLTAGE
	A	B	C	D	E	F	
MAB4L-E01	2.50 (63.50)	1.25 (31.75)	1.00 (25.4)	0.50 (12.70)	0.28 (7.11)	2.50 (63.50)	120 VAC
MAB4L-E02							240 VAC
MAB4L-E03							24 VDC
MAB6L-E01	3.00 (76.2)	1.50 (38.1)	1.50 (38.1)	0.75 (19.05)	0.34 (8.64)	3.00 (76.2)	120 VAC
MAB6L-E02							240 VAC
MAB6L-E03							24 VDC
MAB3XD-E01†	2.50 (63.50)	1.25 (31.75)	1.00 (25.4)	0.50 (12.70)	0.28 (7.11)	2.50 (63.50)	120 VAC
MAB3XD-E02†							240 VAC
MAB3XD-E03†							24 VDC
MAB6XD-E01†	3.00 (76.2)	1.50 (38.1)	1.50 (38.1)	0.75 (19.05)	0.34 (8.64)	3.00 (76.2)	120 VAC
MAB6XD-E02†							240 VAC
MAB6XD-E03†							24 VDC

NOTE:

- Maximum allowable air pressure is 150 psi (10.34)
- 1/2" NPT female air connection
- Manual override
- Powder coated aluminum housing
- CE & CSA approved
- Actuators operating temperature: 0°F to 160°F (-17.8°C to 71°C)
- 120 and 240 Volt are 50/60 Hz, For other voltages consult factory
- †MAB3X and MAB6X are same dimensions as the MAB3XD and MAB6XD
- For other options consult factory

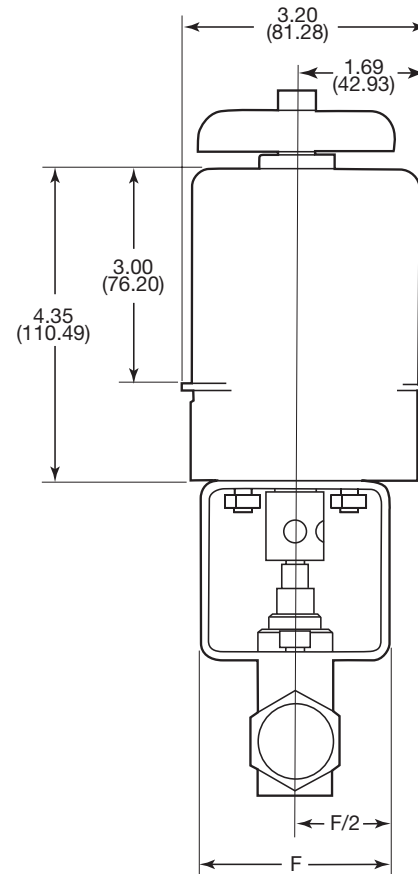
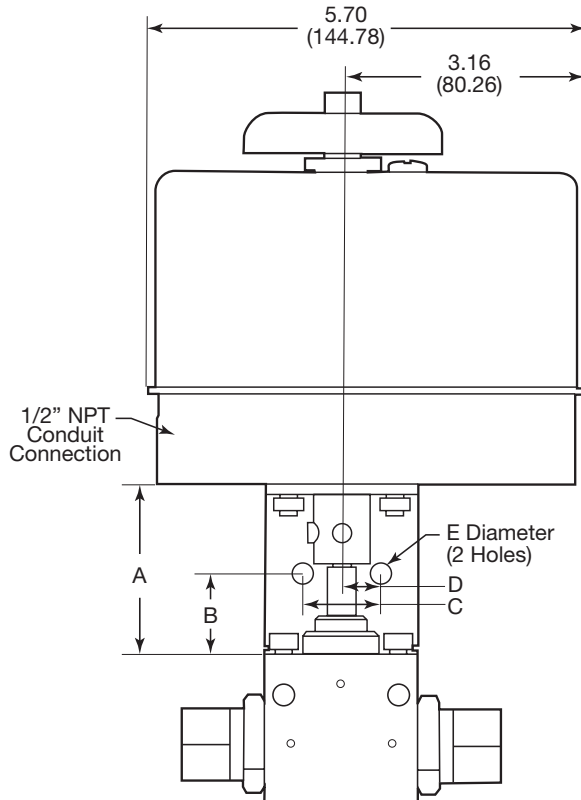

MPI™ Medium Pressure Valves



## Ball Valves: MAB Series Actuators

Pneumatic and Electric

### Electric Operated Ball Valves

Add the suffix **-E01**, **-E02** or **-E03** to the appropriate valve catalog number for a complete valve assembly.

VALVE SERIES	Dimensions Data - inches (mm)						VOLTAGE	
	A	B	C	D	E	F		
MAB8L-E01	3.00 (76.2)	1.50 (38.1)	2.00 (50.8)	1.00 (25.40)	0.53 (13.46)	3.00 (76.2)	120 VAC	See Figure 1
MAB8L-E02							240 VAC	
MAB8L-E03							24 VDC	
MAB8XD-E01†	3.00 (76.2)	1.50 (38.1)	2.00 (50.80)	1.00 (25.40)	0.53 (13.46)	3.00 (76.2)	120 VAC	
MAB8XD-E02†							240 VAC	
MAB8XD-E03†							24 VDC	

**NOTE:**

- E01: Electric 120 VAC
- E02: Electric 220 VAC
- E03: Electric 24 VDC
- For other voltages consult factory
- Actuator operating temperature: 0°F to 160°F (-17.8°C to 71°C)
- Powder coated aluminum housing
- CE & CSA approved for NEMA 4 and 4x
- For other options contact factory
- Manual override
- 1/2" NPT female air connector
- †MAB8X series are the same dimensions as the MAB8XD

MPI™ Medium Pressure Valves

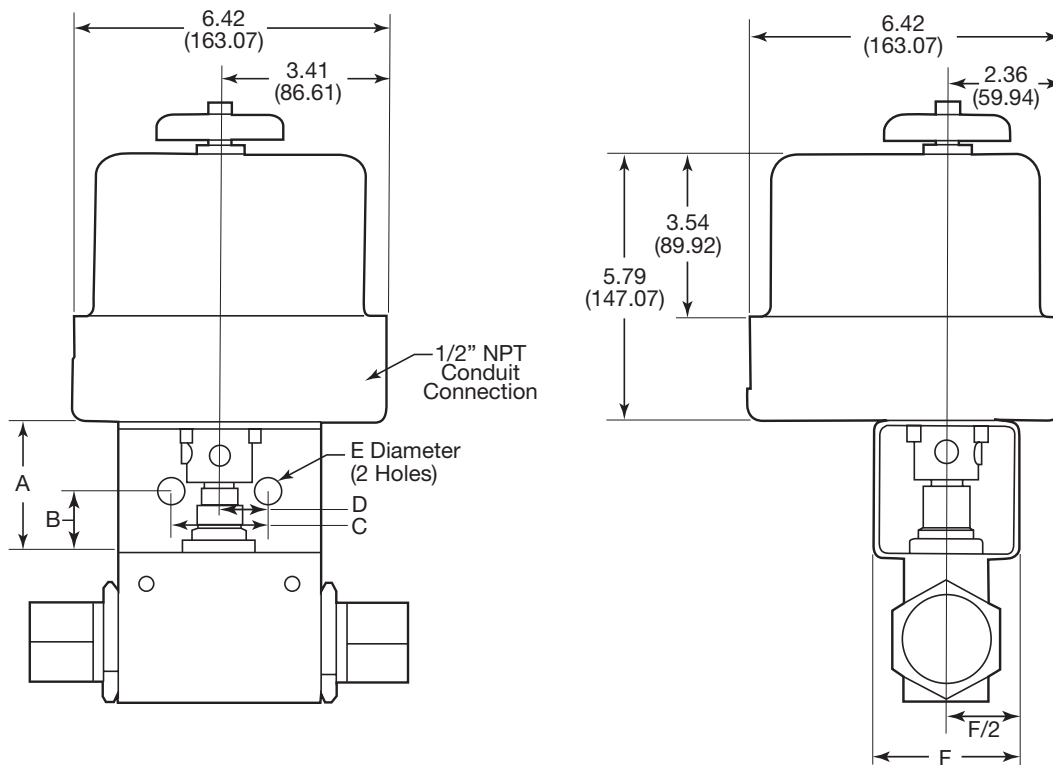

# Double Block and Bleed Ball Valves

Valve Size	Part Number 3 Way 90° Diverter	MAWP PSI	Connection	Inches	
				Minimum Valve Orifice	Overall Length
DBB6	4MP7-MADBB6LPK-V-SS	15,000	1/4" MPI	0.125	10.54
	4F-MADBB6LPK-V-SS	15,000	1/4" NPT	0.125	9.54
	6MP7-MADBB6LPK-V-SS	15,000	3/8" MPI	0.25	10.07
	6F-MADBB6LPK-V-SS	15,000	3/8" NPT	0.25	9.54
	8MP7-MADBB6LPK-V-SS	15,000	1/2" MPI	0.312	10.92
	8F-MADBB6LPK-V-SS	15,000	1/2" NPT	0.312	9.54
	9MP7-MADBB6LPK-V-SS	15,000	9/16" MPI	0.322	11.04
	9F-MADBB6LPK-V-SS	15,000	9/16" NPT	0.322	9.54
DBB10	12MP7-MADBB10LPK-V-SS	15,000	3/4" MPI	0.531	17.17
	12F-MADBB10LPK-V-SS	15,000	3/4" NPT	0.531	15.41
	16MP7-MADBB10LPK-V-SS	12,500	1" MPI	0.625	17.67
	16F-MADBB10LPK-V-SS	12,500	1" NPT	0.625	15.41

Dimensions in inches are for reference only, subject to change.  
All vent connections are sized at 1/4 FNPT.

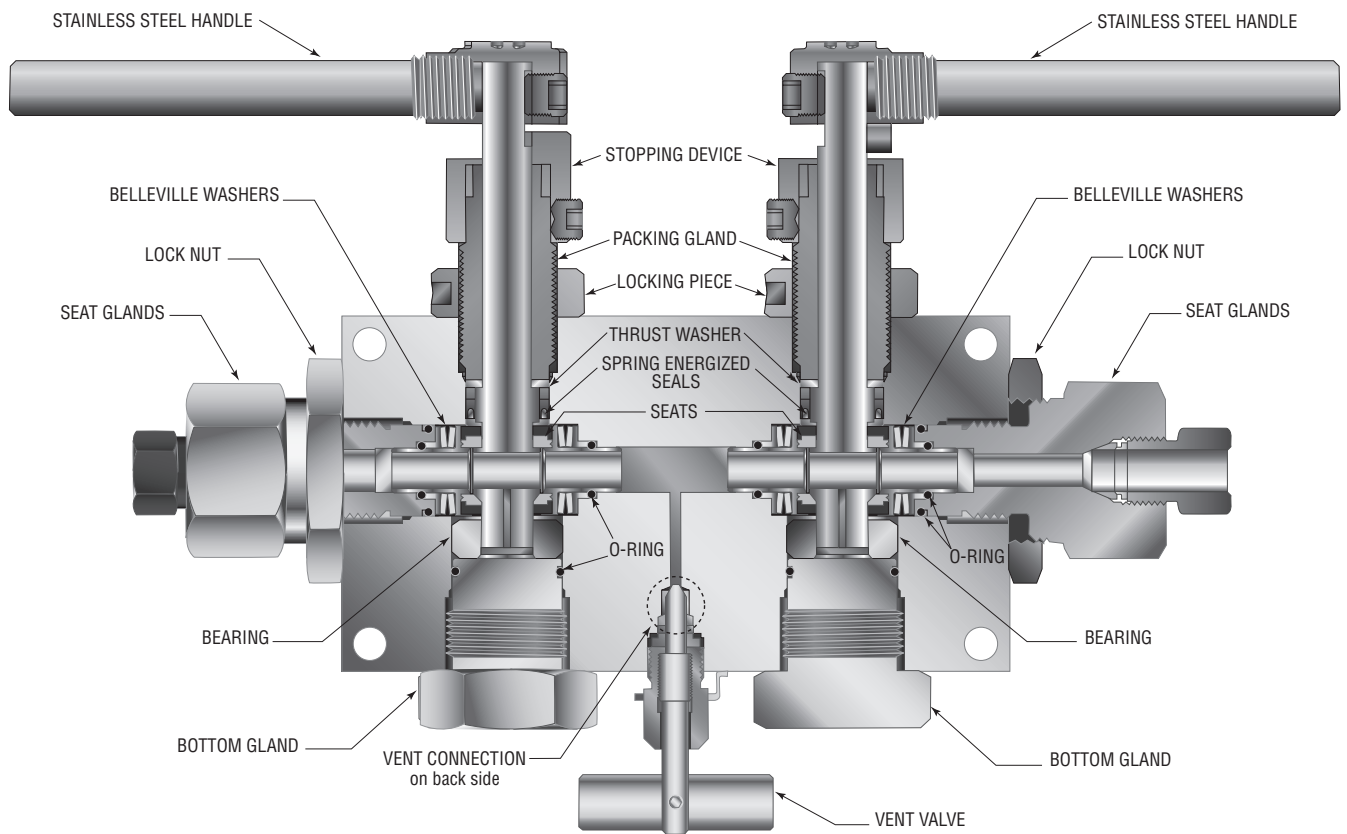

MPI™ Medium Pressure Valves

## Dimensions

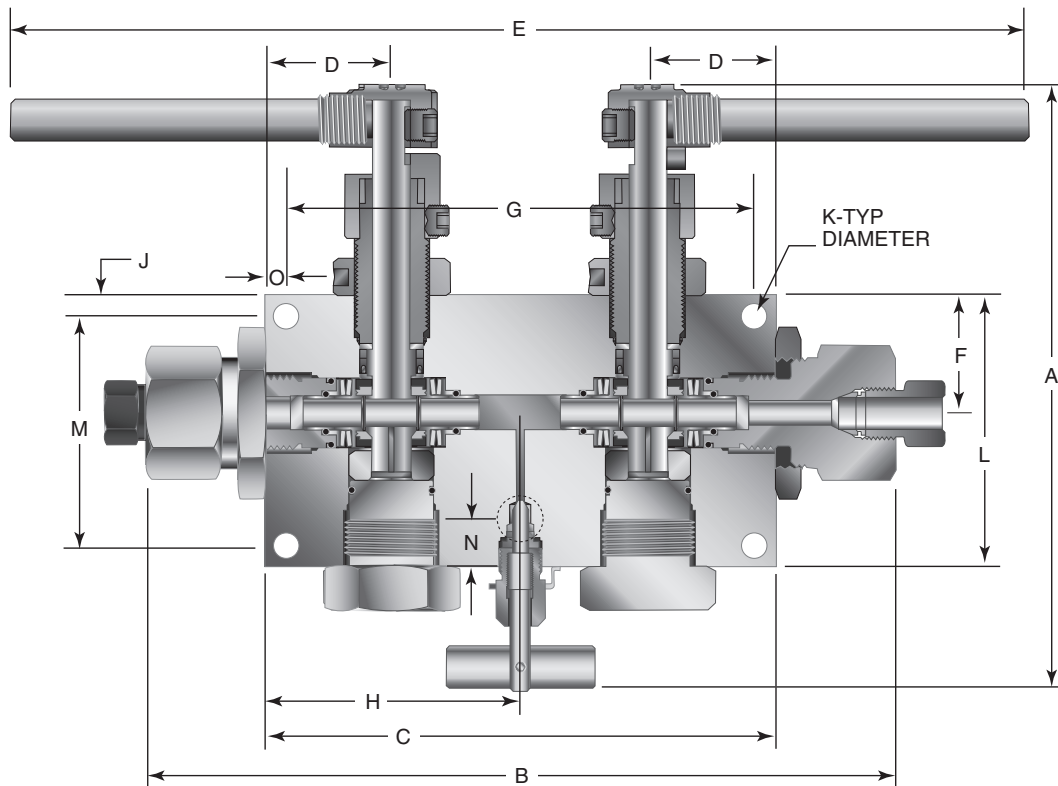

		Inches (mm)													
Valve Size	A	B	C	D	E	F	G	H	J	K	L	M	N	O	Block Th'k
DBB6	7.14 (181.35)	9.54 (242.70)	6.00 (152.44)	1.50 (38.16)	12.98 (330.21)	1.38 (35.11)	5.00 (127.20)	3.00 (76.32)	0.41 (10.43)	0.28 (7.16)	3.19 (81.15)	2.38 (60.55)	0.65 (16.54)	0.50 (12.72)	1.75 (44.52)
DBB10	13.02 (331.23)	15.41 (392.23)	10.51 (267.37)	2.66 (67.67)	27.45 (698.33)	2.53 (64.36)	8.69 (221.07)	5.26 (133.69)	0.72 (18.32)	0.41 (10.34)	5.25 (133.56)	3.81 (96.93)	1.75 (44.45)	0.914 (23.15)	3.00 (76.32)

Dimensions in inches are for reference only, subject to change.

## Panel Hole Sizes

### DBB6 Panel Hole Size

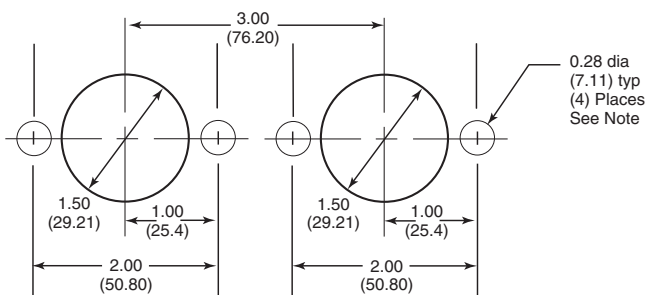

All dimensions are for reference only and are subject to change without notice.

Note: Body Top Mount 1/4-20 Thread

### DBB10 Panel Hole Size

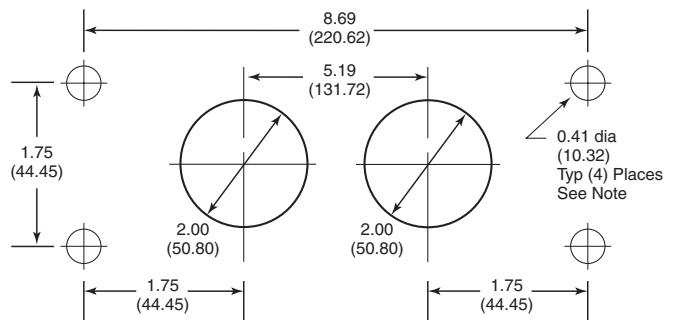

All dimensions are for reference only and are subject to change without notice.

Note: Body Top Mount 3/8-16 Thread

## How to Order DBB Series Valves

The correct part number is easily derived from the following example and ordering chart. The seven product characteristics required are coded as shown in the chart.

Typical part number example: **4MP7-MADBB6LPK-V-SSP** (part number is created based on customer selection of product parameters, see below for example)

4	MP7	-	MADBB	6	X	PK	-	V	-	SSP
Inlet/Outlet Connection Size	Connection Type		Valve Series	Orifice Size	Valve Type	Seat Material		Seal Material		Body Material
<b>4</b> = 1/4" <b>6</b> = 3/8" <b>8</b> = 1/2" <b>9</b> = 9/16" <b>12</b> = 3/4" <b>16</b> = 1"	<b>F</b> = Female Pipe  <b>MP7</b> = Parker MPI™		<b>MADBB</b>	<b>6</b> = 3/8" <b>10</b> = 5/8"	<b>L</b> = 2 Way	<b>PK</b> = PEEK		<b>V***</b> = Fluorocarbon Rubber  <b>KZ</b> = Highly Fluorinated Fluorocarbon Rubber  <b>BN</b> = Nitrile Rubber  <b>EPR</b> = Ethylene Propylene Rubber		<b>SSP</b> = Stainless Steel
								*** Standard packing material		

## How to Order Options

**Lock Out Devices** – add the suffix **-LD** to the end of the part number to specify a factory-installed lock out device.

MPI™ Medium Pressure Valves

## Dual Disc Line Filter

Parker's Dual-Disc Line Filters are utilized in numerous industrial, chemical processing, aerospace, nuclear and other applications. With the dual-disc design, large contaminant particles are trapped by the upstream filter element before they can reach and clog the smaller micron-size downstream element. Filter elements can be easily replaced.

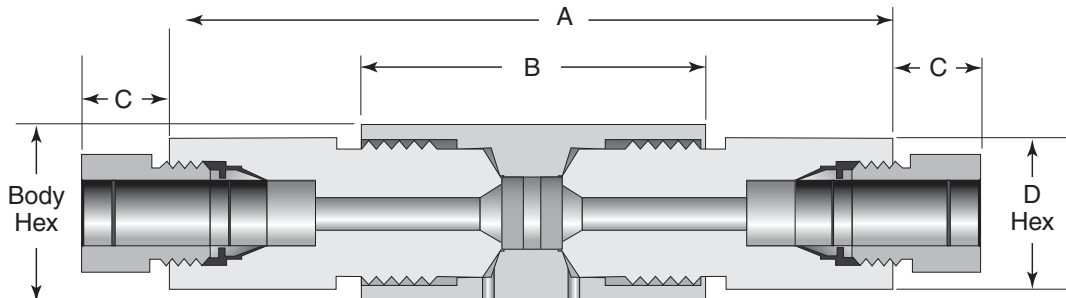

Tubing	Parker Part No. **	Pressure psi (bar)	Orifice inch (mm)	Micron Size	Connection	Dimensions - inches (mm)				
						A	B	C	D	Hex
1/2" O.D.	8MP7-MAFL-35/65-SS	15,000 (1034)	0.359 (9.12)	33/65	1/2" MPI	5.99 (152.15)	2.69 (68.33)	.69 (17.53)	1.19 (30.23)	1.38 (35.05)
	8MP7-MAFL-5/10-SS			5/10						
	8MP7-MAFL-10/35-SS			10/13						
9/16" O.D.	9MP7-MAFL-35/65-SS	15,000 (1034)	0.359 (9.12)	33/65	9/16" MPI	5.99 (152.15)	2.69 (68.33)	.75 (19.05)	1.19 (30.23)	1.38 (35.05)
	9MP7-MAFL-5/10-SS			5/10						
	9MP7-MAFL-10/35-SS			10/13						

\*\*Filter elements downstream/upstream micron size 35/65 is standard.

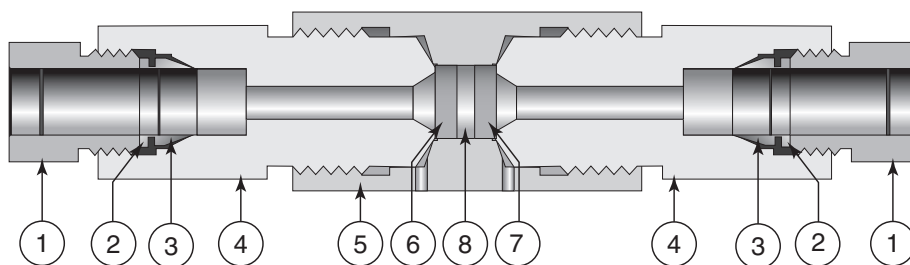

Item#	Part	Material
1	Nut	316 SS
2	Back Ferrule	316 SS
3	Front Ferrule	316 SS
4	Gland Nut	316 SS
5	Body	316 SS
6	Dual Disc Line Filter 65 Microns*	316 L
7	Dual Disc Line Filter 35 Microns*	316 L
8	Filter Gasket	316 SS

\* Per Model Number

**Notes:**

- (1) All filters furnished complete with connection components unless otherwise specified. All dimensions for reference only and subject to change.
- (2) Parker Autoclave Engineers disc and cup type filters are designed to filter small amounts of process particles. It is recommended that all fluids are thoroughly cleaned prior to entering the higher pressure system.
- (3) Special material filters may be supplied with four flats in place of standard hex.
- (4) Pressure differential not to exceed 1,000 psi (69 bar) in a flowing condition.
- (5) Larger micron size filter element is installed on the upstream (inlet) side.

MPI™ Medium Pressure Valves

## Cup Line Filter

Parker's MAFCL series high flow Cup Line Filters are recommended in low pressure systems requiring both high flow rates and maximum filter surface area. Widely used in the industrial and chemical processing fields, the cup design offers as much as six times the effective filter area as compared to disc-type units. In addition, the filter elements can be quickly and easily replaced.

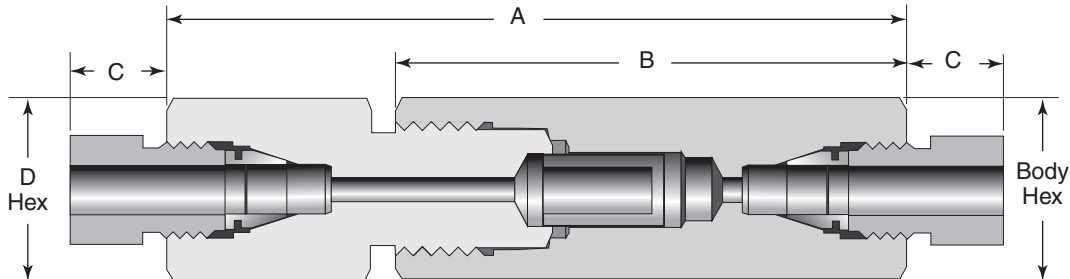

Tubing	Parker Part No. **	Pressure psi (bar)	Orifice inch (mm)	Micron Size	Connection	Dimensions - inches (mm)				
						A	B	C	D	Hex
1/4" O.D.	4MP7-MAFCL-5-SS	15,000 (1034)	0.125 (3.18)	5	1/4" MPI	3.81 (96.77)	2.63 (66.80)	.50 (12.70)	0.81 (20.57)	0.81 (20.57)
	35									
	65									
3/8" O.D.	6MP7-MAFCL-5-SS	15,000 (1034)	0.219 (5.56)	5	3/8" MPI	4.40 (111.76)	3.06 (77.72)	.63 (16.00)	1.00 (25.40)	0.94 (23.88)
	35									
	65									
1/2" O.D.	8MP7-MAFCL-5-SS	15,000 (1034)	0.359 (9.12)	5	1/2" MPI	5.57 (141.48)	3.94 (100.08)	.69 (17.53)	1.19 (30.23)	1.38 (35.05)
	35									
	65									
9/16" O.D.	9MP7-MAFCL-5-SS	15,000 (1034)	0.359 (9.12)	5	9/16" MPI	5.57 (141.48)	3.94 (100.08)	.75 (19.05)	1.19 (30.23)	1.38 (35.05)
	35									
	65									
3/4" O.D.	12MP7-MAFCL-5-SS	15,000 (1034)	0.516 (13.11)	5	3/4" MPI	7.72 (196.09)	5.76 (146.30)	.88 (22.35)	1.88 (47.75)	Ø 2.12 (53.85)
	35									
	65									
1" O.D.	16MP7-MAFCL-5-SS	12,500 (861.85)	0.688 (17.481)	5	14" MPI	8.71 (221.23)	6.25 (158.75)	1.13 (28.70)	1.88 (47.75)	Ø 2.12 (53.85)
	35									
	65									

\*\*Other microns sizes are available on special order

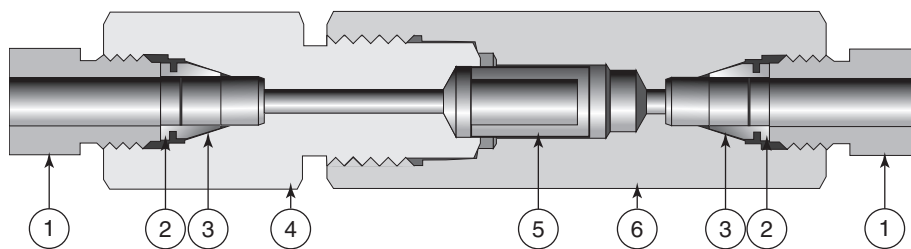

### Material of Construction

Item#	Part	Material
1	Nut	316 SS
2	Back Ferrule	316 SS
3	Front Ferrule	316 SS
4	Gland Nut	316 SS
5	Cup Filter	316 L
6	Body	316 SS
7	Spring (Not shown - only in 1" MPI)	302 SS

#### Notes:

- All filters furnished complete with connection components unless otherwise specified. All dimensions for reference only and subject to change.
- Parker Autoclave Engineers disc and cup type filters are designed to filter small amounts of process particles. It is recommended that all fluids are thoroughly cleaned prior to entering the higher pressure system.
- Special material filters may be supplied with four flats in place of standard hex.
- Pressure differential not to exceed 1,000 psi (69 bar) in a flowing condition.
- Larger micron size filter element is installed on the upstream (inlet) side.

MPI™ Medium Pressure Valves

## Check Valves

Parker's MACBL series (Ball Check Valve) prevent reverse flow where leak-tight shut-off is not mandatory. When differential drops below cracking pressure, valve closes. With all-metal components, valve can be used up to 650°F (343°C). Ball and poppet are an integral design to assure positive, in-line seating without "chatter". Poppet is designed essentially for axial flow with minimum pressure drop.

Parker's MACL series (O-Ring Check Valve) provides unidirectional flow and tight shut-off for liquids and gases with high reliability. When differential drops below cracking pressure\*, valve shuts off. (Not for use as a Relief Valve)

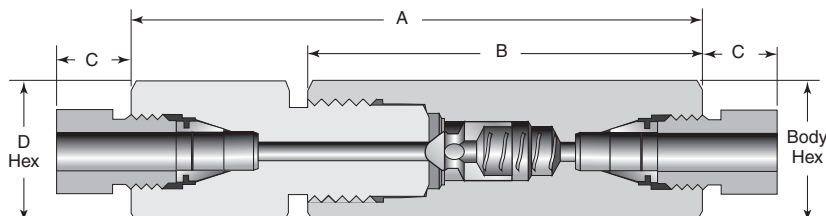

Tubing O.D.	Parker Ball Check Part No.	Parker O-Ring Check Part No.	Pressure psi (bar)	Connection	Orifice inch (mm)	Rated C <sub>v</sub>	Dimensions - inches (mm)				
							A	B	C	D	Hex
1/4"	4MP7-MACBL-20-SS	4MP7-MACL-20-V-SS	15,000 (1034)	1/4" MPI	0.125 (3.18)	0.28	3.80 (96.52)	2.63 (66.80)	.50 (12.70)	0.81 (20.57)	0.81 (20.57)
3/8"	6MP7-MACBL-20-SS	6MP7-MACL-20-V-SS	15,000 (1034)	3/8" MPI	0.219 (5.56)	0.84	4.40 (111.76)	3.06 (77.72)	0.63 (16.00)	0.94 (23.88)	1.00 (25.40)
1/2"	8MP7-MACBL-20-SS	8MP7-MACL-20-V-SS	15,000 (1034)	1/2" MPI	0.359 (9.12)	2.30	5.56 (141.22)	3.94 (100.08)	0.69 (17.53)	1.19 (30.23)	1.38 (35.05)
9/16"	9MP7-MACBL-20-SS	9MP7-MACL-20-V-SS	15,000 (1034)	9/16" MPI	0.359 (9.12)	2.30	5.56 (141.22)	3.94 (100.08)	0.75 (19.05)	1.19 (30.23)	1.38 (35.05)
3/4"	12MP7-MACBL-20-SS	12MP7-MACL-20-V-SS	15,000 (1034)	3/4" MPI	0.516 (13.11)	4.70	7.05 (179.07)	5.13 (130.30)	0.88 (22.35)	1.38 (35.05)	1.75 (44.455)
1"	16MP7-MACBL-20-SS	16MP7-MACL-20-V-SS	12,500 (861.85)	14" MPI	0.688 (17.481)	7.40	8.71 (221.23)	6.25 (158.75)	1.13 (28.70)	1.88 (47.75)	Ø 2.12 (53.85)

Minimum operating temperature for standard ball check valves 0°F (-17.8°C). For low temperature option to -100°F (-73°C) add suffix LT (Low temperature spring).

### Ball Check Valves

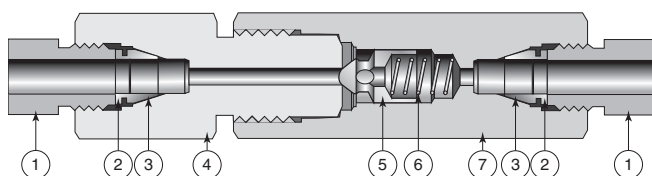

### O-Ring Check Valves

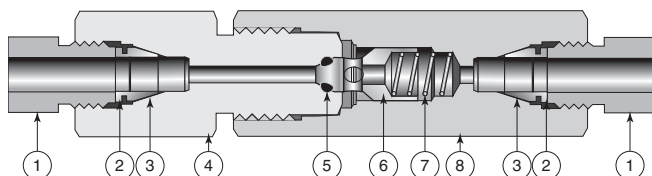

### Material of Construction

Item#	Part	Material
1	Nut	316 SS
2	Back Ferrule	316 SS
3	Front Ferrule	316 SS
4	Gland Nut	316 SS
5	Poppet	316 SS
6	Spring	302 SS
7	Body	316 SS

Item#	Part	Material
1	Nut	316 SS
2	Back Ferrule	316 SS
3	Front Ferrule	316 SS
4	Gland Nut	316 SS
5	O-Ring	Fluorocarbon Rubber*
6	Poppet	316 SS
7	Spring	302 SS
8	Body	316 SS
KZ*	Highly Fluorinated Fluorocarbon Rubber (o-ring optional material)	
BN*	Nitrile Rubber (o-ring optional material)	
EPR*	Ethylene Propylene Rubber (o-ring optional material)	



## Hard Seat Relief Valve

Parker's MARA series (Hard Seat) relief valves provide reliable venting of gases or liquids for set pressures from 3,000 psi (206.8 bar) minimum to 75,000 psi (5171 bar). The standard temperature range for all models is -423°F to 400°F (-252°C to 204°C). A high temperature option to 750°F (399°C) is also available. These precision valves are designed for pressure gas systems, cryogenic systems, petrochemical applications and other special systems.

These precision valves are designed for pressure gas systems, where zero leakage is critical. They are not recommended for liquid nitrogen or liquid carbon dioxide, which produce gas at cryogenic temperatures upon relief. Relief valves are designed to open proportionally to increasing pressure. Therefore, they are not recommended for applications requiring immediate full valve flow at set pressure (such as decompositions, polymerizations, etc.). Full flow of relief valve is defined at 10% over set pressure.

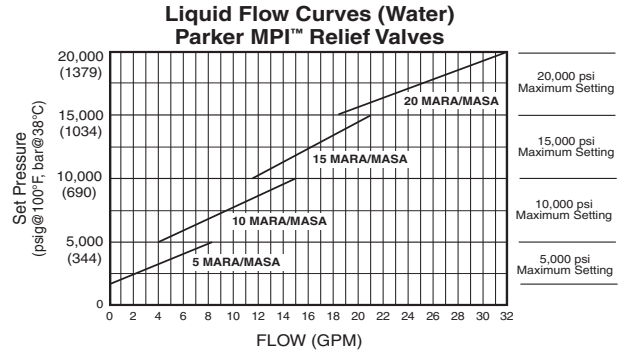
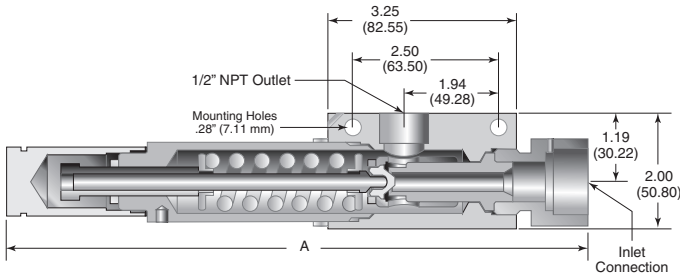

Hard Seat Part No.	Connection Size & Type		Orifice Diameter inches (mm)	Pressure Rating psi (bar) @ 100° F (38° C)			Dimension inches (mm) A
	Inlet Connection	Outlet Connection		Minimum Setting	Maximum Setting	Maximum Back Press.	
8M8F-MARA-****-SS	1/2" MNPT	1/2" FNPT	0.312 (7.92)	3,000 (206.84)	5,000 (344.73)	500 (34.47)	11.16 (283.45)
8M8F-MARA-****-SS	1/2" MNPT	1/2" FNPT	0.250 (6.35)	5,000 (344.73)	10,000 (689.46)	500 (34.47)	11.16 (283.45)
8MP78F-MARA-****-SS	1/2" MNPT	1/2" FNPT	0.188 (4.78)	10,000 (689.45)	15,000 (1034.20)	500 (34.47)	11.16 (283.45)
9MP78F-MARA-****-SS	9/16" MNPT	1/2" FNPT	0.188 (4.78)	10,000 (689.45)	15,000 (1034.20)	500 (34.47)	11.16 (283.45)
9HF8F-MARA-****-SS	9/16" HP C&T	1/2" FNPT	0.188 (4.78)	10,000 (689.45)	15,000 (1034.20)	500 (34.47)	9.52 (241.81)
9HF8F-MARA-****-SS	9/16" HP C&T	1/2" FNPT	0.156 (3.96)	15,000 (1034.20)	20,000 (1378.93)	500 (34.47)	9.52 (241.81)

MPI™ Medium Pressure Valves

### Hard Seat Relief Valve

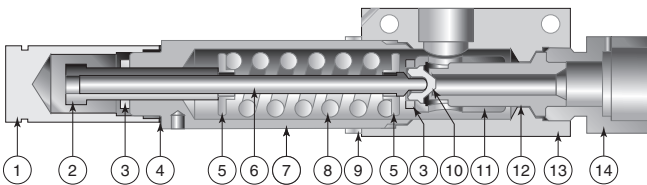

### Material of Construction

Item#	Part (Hard Seat / Soft Seat)	Material
1	Cap	316 SS
2	Adjusting Bolt	Nitronic 60
3	Locknut	316 SS
4	Gasket	304 SS Annealed
5	Spring Washer	316 SS
6	Spindle	316 SS
7	Spring Cylinder	316 SS
8	Spring	316 SS
9	Locknut	316 SS
10	Plug / Plug Gland	316 SS
11	Plug Guide / Plug	Nitronic 60 / 316 SS
12	Seat / Plug Guide	316 SS / Nitronic 60
13	Body / Seat	316 SS
14	Seat Gland / Body	316 SS
15	Nameplate (Not Shown) / Seat Gland	304 SS / 316 SS
16	Cable (Not Shown) / Nameplate (Not Shown)	316 SS
17	Splicing Sleeve (Not Shown) / Cable (Not Shown)	316 SS
18	- / Splicing Sleeve (Not Shown)	316 SS

## Soft Seat Relief Valve

Capable of handling air, gases, steam, vapor and liquids, they are however, not recommended for steam boiler applications nor are they ASME code complaint. Parker's MARSA series (Soft Seat) relief valves utilize a soft seat design for reliable venting of gases at set pressures from 1,500 psi (103 bar) to 20,000 psi (1378 bar). The operating temperature range is 32°F (0°C) to 400°F (204°F). The soft seat design provides bubble tight sealing, repeatable pop-off, and reseal. Additionally, soft seat valves provide a higher cycle life than metal seat relief valves.

These precision valves are designed for pressure gas systems, where zero leakage is critical. They are not recommended for liquid nitrogen or liquid carbon dioxide, which produce gas at cryogenic temperatures upon relief. Relief valves are designed to open proportionally to increasing pressure. Therefore, they are not recommended for applications requiring immediate full valve flow at set pressure (such as decompositions, polymerizations, etc.). Full flow of relief valve is defined at 10% over set pressure.

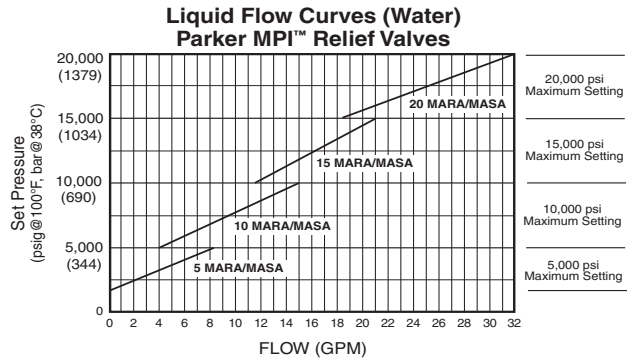
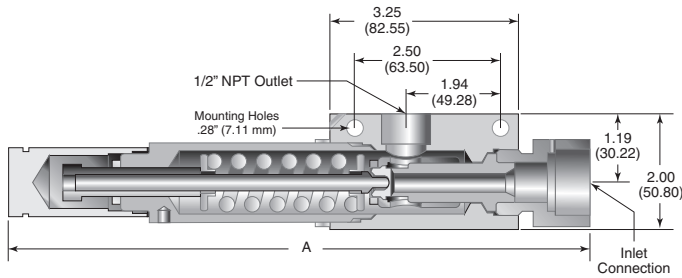

MPI™ Medium Pressure Valves

Soft Seat Part No.	Connection Size & Type		Orifice Diameter inches (mm)	Pressure Rating psi (bar) @ 100° F (38° C)			Dimension inches (mm)
	Inlet Connection	Outlet Connection		Minimum Setting	Maximum Setting	Maximum Back Press.	A
8M8F-MARSA-****-SS	1/2" MNPT	1/2" FNPT	0.312 (7.92)	1,500 (103.42)	5,000 (344.73)	500 (34.47)	11.16 (283.45)
8M8F-MARSA-****-SS	1/2" MNPT	1/2" FNPT	0.250 (6.35)	5,000 (344.73)	10,000 (689.46)	500 (34.47)	11.16 (283.45)
8MP78F-MARSA-****-SS	1/2" MNPT	1/2" FNPT	0.188 (4.78)	10,000 (689.45)	15,000 (1034.20)	500 (34.47)	11.16 (283.45)
9MP78F-MARSA-****-SS	9/16" MNPT	1/2" FNPT	0.188 (4.78)	10,000 (689.45)	15,000 (1034.20)	500 (34.47)	11.16 (283.45)
9HF8F-MARSA-****-SS	9/16" HP C&T	1/2" FNPT	0.188 (4.78)	10,000 (689.45)	15,000 (1034.20)	500 (34.47)	9.52 (241.81)
9HF8F-MARSA-****-SS	9/16" HP C&T	1/2" FNPT	0.156 (3.96)	15,000 (1034.20)	20,000 (1378.93)	500 (34.47)	9.52 (241.81)

### Soft Seat Relief Valve

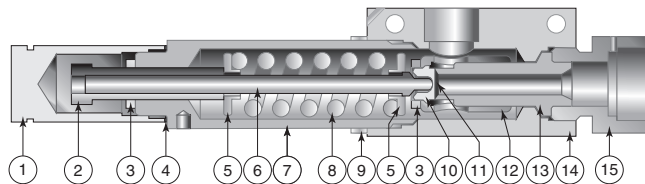

### Material of Construction

Item#	Part	Material	Item#	Part	Material
1	Cap	316 SS	10	Plug Gland	316 SS
2	Adjusting Bolt	Nitronic 60	11	Plug	316 SS
3	Locknut	316 SS	12	Plug Guide	Nitronic 60
4	Gasket	304 SS Annealed	13	Body /Seat	316 SS
5	Spring Washer	316 SS	14	Body	316 SS
6	Spindle	316 SS	15	Seat Gland	316 SS
7	Spring Cylinder	316 SS	16	Nameplate (Not Shown)	316 SS
8	Spring	316 SS	17	Cable (Not Shown)	316 SS
9	Locknut	316 SS	18	Splicing Sleeve (Not Shown)	316 SS

Parker MPI™ Fittings can be assembled by hand but hydraulic preset is recommended for 3/4" and required for 1" to insure proper markup.

## Assembly

1. Parker MPI™ Fittings are sold completely assembled and ready for immediate use. Simply insert the tube as illustrated until it bottoms in the fitting body. (If the fitting is disassembled, note that the small tapered end of the ferrule(s) go into the fitting body.)

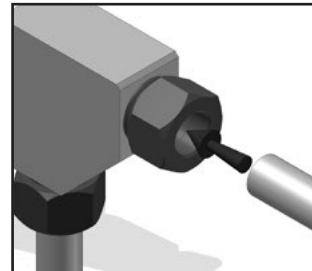

2. Turn the nut to the "finger-tight" position. Hold the fitting body with a second wrench to prevent the body from turning as you tighten the nut. For hand assembly, tighten the nut 1-1/2 turns. For 3/4" and 1" sizes, preset the nut and ferrules and then tighten the nut 1/2 turn only. [See page 58 & 59](#) for more information on preset connections. Parker recommends that you mark the nut (using a scribe or ink) to help you count the turns.

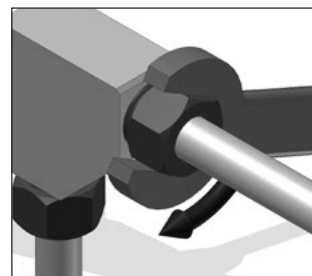

## Gaugeability

Check the gap between the nut and the body hex with the end of the gauge by inserting the gauge (as shown) into the beveled gap between the nut and body hex. Gently turn the gauge (that is, it "twists out"). However, if the gauge slides into the beveled gap, (does not "twist out") the fitting is not properly made up and you must check the entire assembly procedure.



Technical  
Information

## Remake

For maximum number of remakes, mark the fitting and nut before disassembly. Before retightening, make sure the assembly has been inserted into the fitting until the ferrule seats in the fitting. Retighten the nut by hand. Rotate the nut with a wrench to the original position as indicated by the previous marks lining up. (A noticeable increase in mechanical resistance will be felt indicating the ferrule is being re-sprung into sealing position.)

## Gap Gauge

This one handy gauge works for all MPI™ sizes. The end of the gauge checks the fitting gap after make-up.

Parker Part Number: **MPI GAP GAUGE**



Gap Gauge

## MPI™ Hydraulic Preset Tools

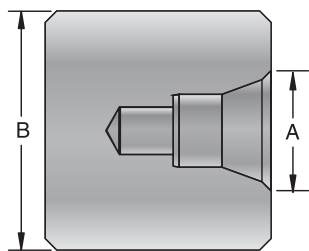

MPI™ Body Die

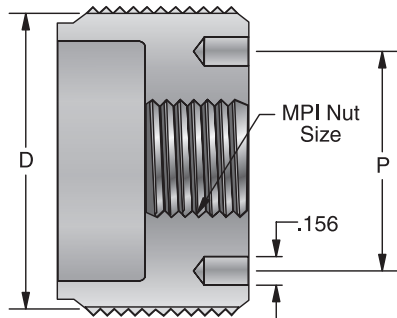

MPI™ Nut Die

### 316 Tubing

Body Dies and Nut Dies Used with the MPI™ Small Preset Assembly

MPI Small Preset Assembly		Inches					MPI™ Nut Size	Preset Pressure PSIG
Body Die Part No.	Nut Die Part No.	A	B	D	P			
4 MPI Body Die	4 MPI Nut Die	.50	.50	.50	.50	.50	3,200	
6 MPI Body Die	6 MPI Nut Die	.63	.63	.63	.63	.63	4,000	
8 MPI Body Die	8 MPI Nut Die	.82	.82	.82	.82	.82	6,800	
9 MPI Body Die	9 MPI Nut Die	.88	.88	.88	.88	.88	8,500	

Dimensions in inches are for reference only, subject to change.

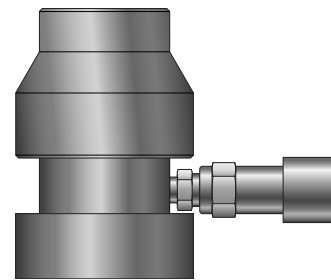

Parker Part No.  
MPI SMALL Preset Assembly

Body Dies and Nut Dies Used with the MPI™ Large Preset Assembly

MPI Large Preset Assembly		Inches					MPI™ Nut Size	Preset Pressure PSIG
Body Die Part No.	Nut Die Part No.	A	B	D	P			
*9 MPI Body Die	9 MPI Large Nut Die	.88	1.25	2.00	1.67	9	3,600	
12 MPI Body Die	12 MPI Nut Die	1.13	1.75	2.00	1.67	12	5,200	
16 MPI Body Die	16 MPI Nut Die	1.44	1.75	2.00	1.67	16	8,000	

\* Requires a 9 MPI Body Die Adapter  
Dimensions in inches are for reference only, subject to change.

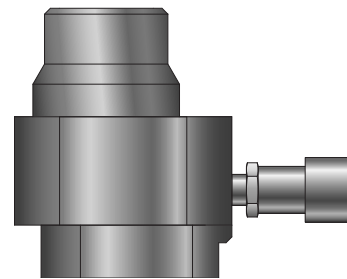

Parker Part No.  
MPI LARGE Preset Assembly

Technical Information

## MPI™ Hydraulic Preset Tools

### 2507 Tubing

Body Dies and Nut Dies Used with the MPI™ Small Preset Assembly

MPI Small Preset Assembly		Inches					MPI™ Nut Size	Preset Pressure PSIG
Body Die Part No.	Nut Die Part No.	A	B	D	P			
6 MPI Body Die	6 MPI Nut Die	.63	.63	.63	.63	.63	4,400	
8 MPI Body Die	8 MPI Nut Die	.82	.82	.82	.82	.82	8,000	

Dimensions in inches are for reference only, subject to change.

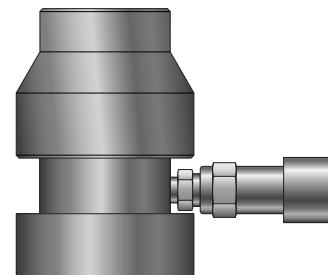

Parker Part No.  
**MPI SMALL Preset Assembly**

Body Dies and Nut Dies Used with the MPI™ Large Preset Assembly

MPI Large Preset Assembly		Inches					MPI™ Nut Size	Preset Pressure PSIG
Body Die Part No.	Nut Die Part No.	A	B	D	P			
10 MPI Body Die	10 MPI Nut Die						4,400	
12 MPI Body Die	12 MPI Nut Die	1.13	1.75	2.00	1.67	12	5,600	
16 MPI Body Die	16 MPI Nut Die	1.44	1.75	2.00	1.67	16	8,800	

\* Requires a 9 MPI Body Die Adapter  
Dimensions in inches are for reference only, subject to change.

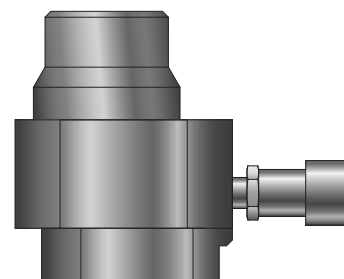

Parker Part No.  
**MPI LARGE Preset Assembly**

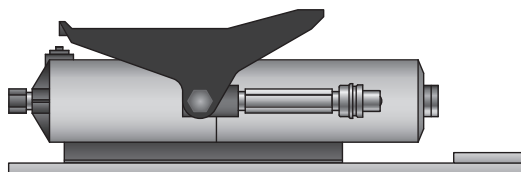

Parker Part No.  
**MPI AIR PUMP KIT**

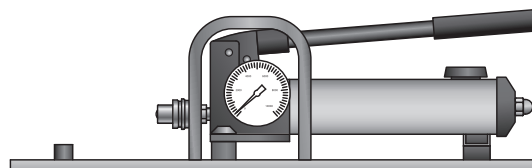

Parker Part No.  
**MPI HAND PUMP KIT**

Note: One Pump Kit, Preset Assembly, Body Die and Nut Die are required for presetting. Pump Kits and Preset Assemblies can be interchanged but Body Dies and Nut Dies are for a specific Preset Assembly. Detailed operating instructions are included with each kit. Copies may also be obtained by contacting the Division.

Technical Information

## Port Dimensions for Parker X44™ Adapter

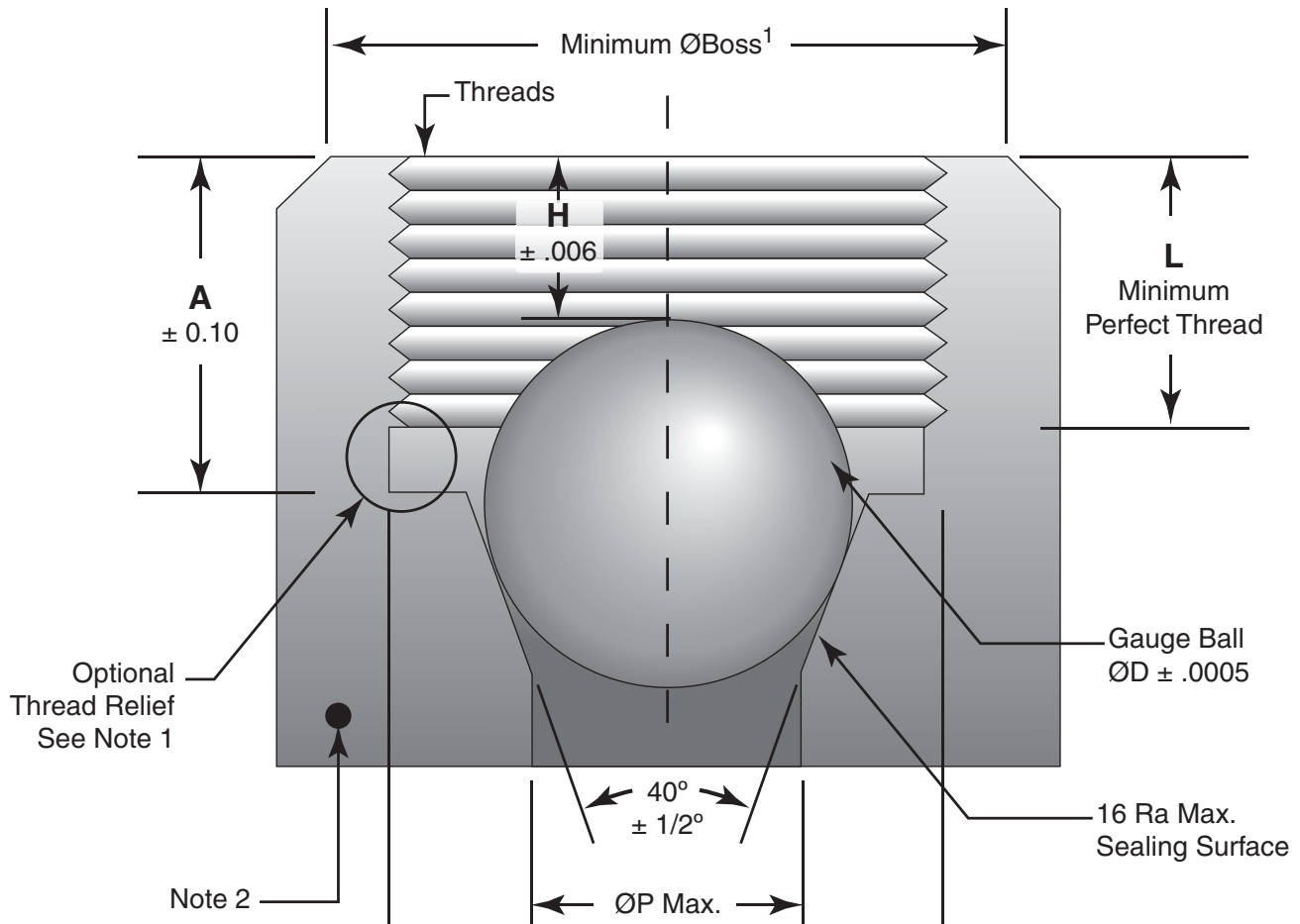

Port Dimensions for Parker X44™ Adapter								
Size	Threads	A	ØD	H	L	ØP Max.	Min. ØBoss	Maximum Working Pressure PSI
6	5/8-18 UNF-2B	.516	.3750	.386	.409	.291	3/4	15,000
9	7/8-14 UNF-2B	.547	.6250	.222	.435	.385	1-1/16	15,000
12	1-1/8-12 UNF-2B	.680	.7500	.324	.549	.541	1-3/8	15,000

Note:

1. If produced with the optional thread relief, the minimum boss diameter shall be increased by 1/16"
2. 60,000 psi minimum yield strength required for port material.
3. ØP is the maximum thru hole. Standard drill size is .01
4. All dimensions are in inches unless otherwise specified.

## Port Dimensions for Parker X42™ Adapter Medium Pressure Cone and Thread Port

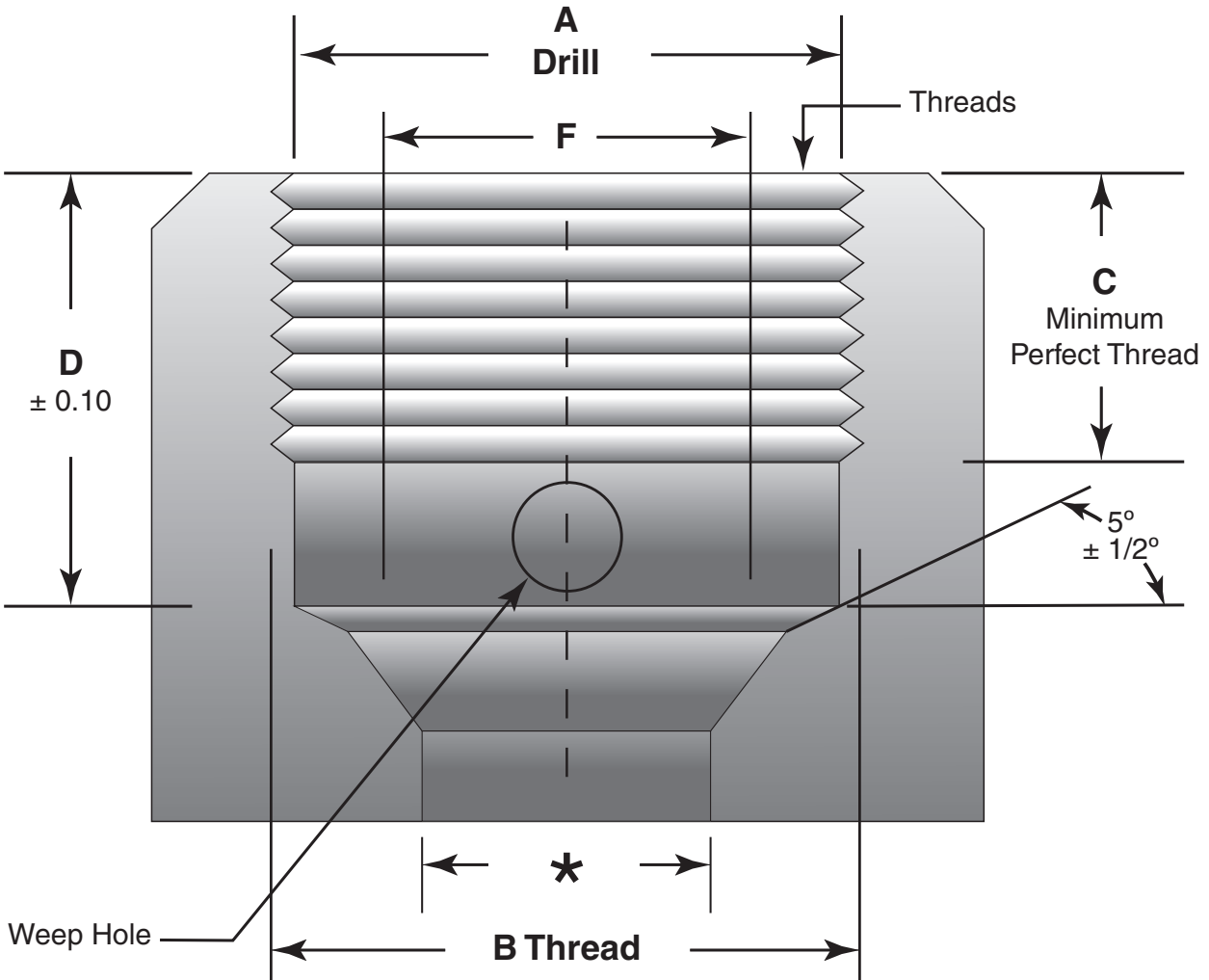

Technical  
Information

Port Dimensions for Parker X42™ Adapter - inches (mm)						
Size = in (mm)	Connection Size	A	B	C	D	F
4 = 1/4" (6.35)	SF250CX20	25/64 (9.92)	7/16 - 20 (11.10) - 20	0.28 (7.11)	0.50 (12.70)	0.19 (4.83)
6 = 3/8" (9.53)	SF375CX20	33/64 (13.10)	9/16 - 18 (14.30) - 18	0.38 (9.65)	0.62 (15.70)	0.31 (7.87)
8 = 9/16" (14.30)	SF562CX20	3/4 (19.10)	13/16 - 16 (20.60) - 16	0.44 (11.20)	0.75 (19.10)	0.50 (12.70)
10 = 3/4" (19.10)	SF750CX20	61/64 (24.20)	3/4 - 14 <sub>Z</sub> (19.10) - 14 <sub>Z</sub>	0.50 (12.70)	0.94 (23.90)	0.62 (15.70)
12 = 1" (25.40)	SF1000CX20	1-19/64 (32.90)	1-3/8 - 12 (34.90) - 12	0.81 (20.60)	1.31 (33.30)	0.88 (22.40)
14 = 1-1/2" (38.10)	SF1500CX20	1-25/32 (45.24)	1-7/8 - 12 (47.63) - 12	1.00 (25.40)	1.59 (10.49)	1.38 (34.93)

Note:

1. Z= NPS Male Tap
2. All dimensions are shown for reference only and should not be considered as actual machine dimensions
3. \* For port diameter please see orifice sizes for specific valves and fittings
4. \*\* For male tubing end preparation, please see pages "Tools, Installation" section in main catalog.
5. All threads are manufactured to a class 2A or 2B fit.

## Port Dimensions for Parker X41™ Adapter High Pressure Cone and Thread Port

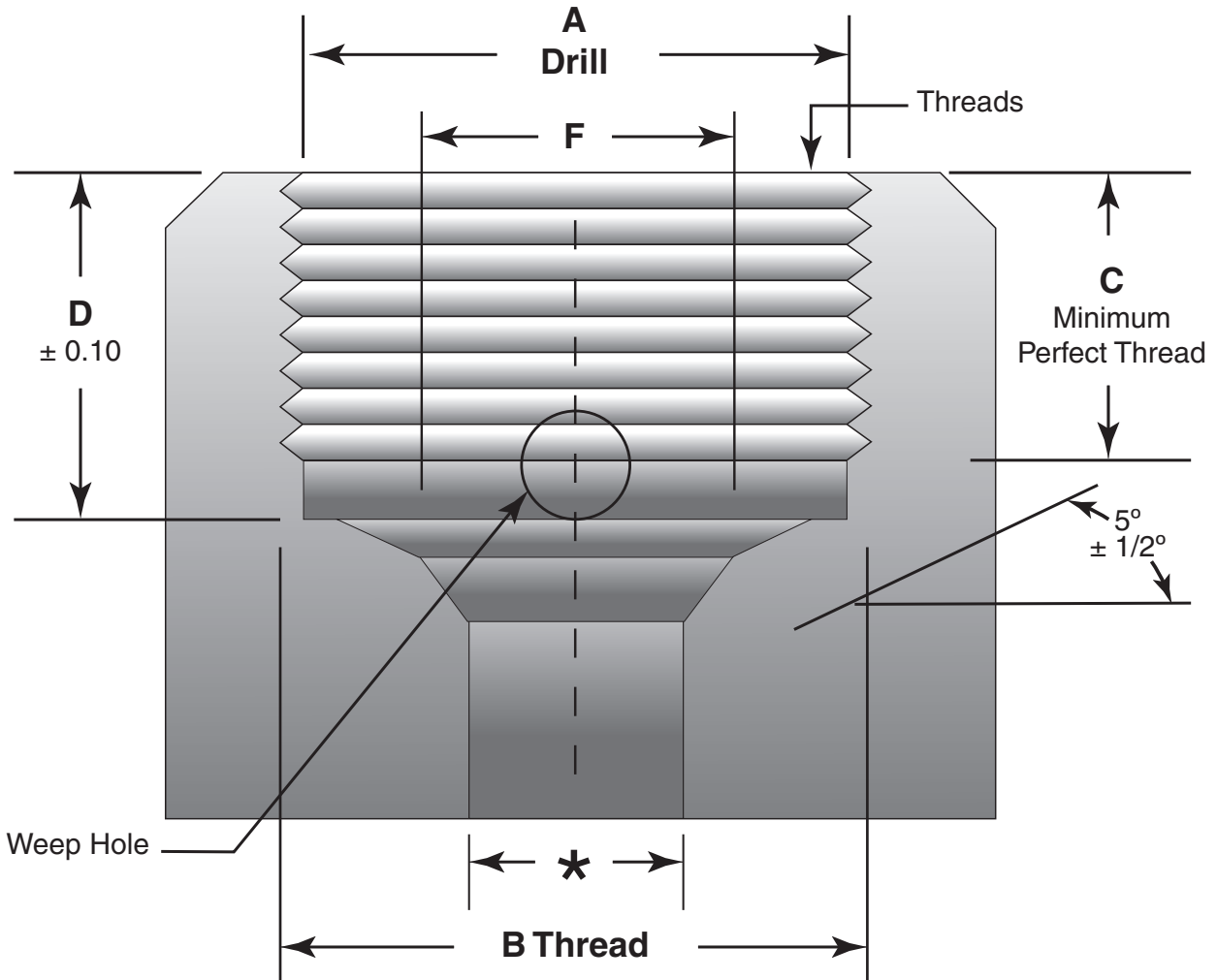

Port Dimensions for Parker X41™ Adapter - inches (mm)						
Size = in (mm)	Connection Size	A	B	C	D	F
4 = 1/4" (6.35)	F250C	33/64 (13.10)	9/16 - 18 (14.30) - 18	0.38 (9.65)	0.44 (11.20)	0.17 (4.32)
6 = 3/8" (9.53)	F375C	11/16 (17.50)	3/4 - 16 (19.10) - 16	0.53 (13.50)	0.62 (15.70)	0.26 (6.60)
8 = 9/16" (14.30)	F562C	1-3/64 (26.60)	1-1/8 - 12 (28.60) - 12	0.62 (15.70)	0.75 (19.10)	0.38 (9.65)

**Note:**

1. Z= NPS Male Tap
2. All dimensions are shown for reference only and should not be considered as actual machine dimensions
3. \* For port diameter please see orifice sizes for specific valves and fittings
4. \*\* For male tubing end preparation, please see pages "Tools, Installation" section in main catalog.
5. All threads are manufactured to a class 2A or 2B fit.



## Terms of Sale with Warranty Limitations

The items described in this document and other documents and descriptions provided by Parker Hannifin Corporation, its subsidiaries and its authorized distributors (“Seller”) are hereby offered for sale at prices to be established by Seller. This offer and its acceptance by any customer (“Buyer”) shall be governed by all of the following Terms and Conditions. Buyer’s order for any item described in its document, when communicated to Seller verbally, or in writing, shall constitute acceptance of this offer. All goods or work described will be referred to as “Products”.

**1. Terms and Conditions.** Seller’s willingness to offer Products, or accept an order for Products, to or from Buyer is expressly conditioned on Buyer’s assent to these Terms and Conditions and to the terms and conditions found on-line at [www.parker.com/saleterms/](http://www.parker.com/saleterms/). Seller objects to any contrary or additional term or condition of Buyer’s order or any other document issued by Buyer.

**2. Price Adjustments; Payments.** Prices stated on the reverse side or preceding pages of this document are valid for 30 days. After 30 days, Seller may change prices to reflect any increase in its costs resulting from state, federal or local legislation, price increases from its suppliers, or any change in the rate, charge, or classification of any carrier. The prices stated on the reverse or preceding pages of this document do not include any sales, use, or other taxes unless so stated specifically. Unless otherwise specified by Seller, all prices are F.O.B. Seller’s facility, and payment is due 30 days from the date of invoice. After 30 days, Buyer shall pay interest on any unpaid invoices at the rate of 1.5% per month or the maximum allowable rate under applicable law.

**3. Delivery Dates; Title and Risk; Shipment.** All delivery dates are approximate and Seller shall not be responsible for any damages resulting from any delay. Regardless of the manner of shipment, title to any products and risk of loss or damage shall pass to Buyer upon tender to the carrier at Seller’s facility (i.e., when it’s on the truck, it’s yours). Unless otherwise stated, Seller may exercise its judgment in choosing the carrier and means of delivery. No deferment of shipment at Buyers’ request beyond the respective dates indicated will be made except on terms that will indemnify, defend and hold Seller harmless against all loss and additional expense. Buyer shall be responsible for any additional shipping charges incurred by Seller due to Buyer’s changes in shipping, product specifications or in accordance with Section 13, herein.

**4. Warranty.** Seller warrants that the Products sold hereunder shall be free from defects in material or workmanship for a period of twelve months from the date of delivery to Buyer or 2,000 hours of normal use, whichever occurs first. This warranty is made only to Buyer and does not extend to anyone to whom Products are sold after purchased from Seller. The prices charged for Seller’s products are based upon the exclusive limited warranty stated above, and upon the following disclaimer: **DISCLAIMER OF WARRANTY: THIS WARRANTY COMPRISES THE SOLE AND ENTIRE WARRANTY PERTAINING TO PRODUCTS PROVIDED HEREUNDER. SELLER DISCLAIMS ALL OTHER WARRANTIES, EXPRESS AND IMPLIED, INCLUDING MERCHANTABILITY AND FITNESS FOR A PARTICULAR PURPOSE.**

**5. Claims; Commencement of Actions.** Buyer shall promptly inspect all Products upon delivery. No claims for shortages will be allowed unless reported to the Seller within 10 days of delivery. No other claims against Seller will

be allowed unless asserted in writing within 60 days after delivery or, in the case of an alleged breach of warranty, within 30 days after the date within the warranty period on which the defect is or should have been discovered by Buyer. Any action based upon breach of this agreement or upon any other claim arising out of this sale (other than an action by Seller for any amount due to Seller from Buyer) must be commenced within thirteen months from the date of tender of delivery by Seller or, for a cause of action based upon an alleged breach of warranty, within thirteen months from the date within the warranty period on which the defect is or should have been discovered by Buyer.

**6. LIMITATION OF LIABILITY.** UPON NOTIFICATION, SELLER WILL, AT ITS OPTION, REPAIR OR REPLACE A DEFECTIVE PRODUCT, OR REFUND THE PURCHASE PRICE. IN NO EVENT SHALL SELLER BE LIABLE TO BUYER FOR ANY SPECIAL, INDIRECT, INCIDENTAL OR CONSEQUENTIAL DAMAGES ARISING OUT OF, OR AS THE RESULT OF, THE SALE, DELIVERY, NON-DELIVERY, SERVICING, USE OR LOSS OF USE OF THE PRODUCTS OR ANY PART THEREOF, OR FOR ANY CHARGES OR EXPENSES OF ANY NATURE INCURRED WITHOUT SELLER’S WRITTEN CONSENT, EVEN IF SELLER HAS BEEN NEGLIGENT, WHETHER IN CONTRACT, TORT OR OTHER LEGAL THEORY. IN NO EVENT SHALL SELLER’S LIABILITY UNDER ANY CLAIM MADE BY BUYER EXCEED THE PURCHASE PRICE OF THE PRODUCTS.

**7. Contingencies.** Seller shall not be liable for any default or delay in performance if caused by circumstances beyond the reasonable control of Seller.

**8. User Responsibility.** The user, through its own analysis and testing, is solely responsible for making the final selection of the system and Product and assuring that all performance, endurance, maintenance, safety and warning requirements of the application are met. The user must analyze all aspects of the application and follow applicable industry standards and Product information. If Seller provides Product or system options, the user is responsible for determining that such data and specifications are suitable and sufficient for all applications and reasonably foreseeable uses of the Products or systems.

**9. Loss to Buyer’s Property.** Any designs, tools, patterns, materials, drawings, confidential information or equipment furnished by Buyer or any other items which become Buyer’s property, may be considered obsolete and may be destroyed by Seller after two consecutive years have elapsed without Buyer placing an order for the items which are manufactured using such property. Seller shall not be responsible for any loss or damage to such property while it is in Seller’s possession or control.

**10. Special Tooling.** A tooling charge may be imposed for any special tooling, including without limitation, dies, fixtures, molds and patterns, acquired to manufacture Products.



Such special tooling shall be and remain Seller's property notwithstanding payment of any charges by Buyer. In no event will Buyer acquire any interest in apparatus belonging to Seller which is utilized in the manufacture of the Products, even if such apparatus has been specially converted or adapted for such manufacture and notwithstanding any charges paid by Buyer. Unless otherwise agreed, Seller shall have the right to alter, discard or otherwise dispose of any special tooling or other property in its sole discretion at any time.

**11. Buyer's Obligation; Rights of Seller.** To secure payment of all sums due or otherwise, Seller shall retain a security interest in the goods delivered and this agreement shall be deemed a Security Agreement under the Uniform Commercial Code. Buyer authorizes Seller as its attorney to execute and file on Buyer's behalf all documents Seller deems necessary to perfect its security interest. Seller shall have a security interest in, and lien upon, any property of Buyer in Seller's possession as security for the payment of any amounts owed to Seller by Buyer.

**12. Improper use and Indemnity.** Buyer shall indemnify, defend, and hold Seller harmless from any claim, liability, damages, lawsuits, and costs (including attorney fees), whether for personal injury, property damage, patent, trademark or copyright infringement or any other claim, brought by or incurred by Buyer, Buyer's employees, or any other person, arising out of: (a) improper selection, improper application or other misuse of Products purchased by Buyer from Seller; (b) any act or omission, negligent or otherwise, of Buyer; (c) Seller's use of patterns, plans, drawings, or specifications furnished by Buyer to manufacture Product; or (d) Buyer's failure to comply with these terms and conditions. Seller shall not indemnify Buyer under any circumstance except as otherwise provided.

**13. Cancellations and Changes.** Orders shall not be subject to cancellation or change by Buyer for any reason, except with Seller's written consent and upon terms that will indemnify, defend and hold Seller harmless against all direct, incidental and consequential loss or damage. Seller may change product features, specifications, designs and availability with notice to Buyer.

**14. Limitation on Assignment.** Buyer may not assign its rights or obligations under this agreement without the prior written consent of Seller.

**15. Entire Agreement.** This agreement contains the entire agreement between the Buyer and Seller and constitutes the final, complete and exclusive expression of the terms of the agreement. All prior or contemporaneous written or oral agreements or negotiations with respect to the subject matter are herein merged.

**16. Waiver and Severability.** Failure to enforce any provision of this agreement will not waive that provision nor will any such failure prejudice Seller's right to enforce that provision in the future. Invalidation of any provision of this agreement by legislation or other rule of law shall not invalidate any other provision herein. The remaining provisions of this agreement will remain in full force and effect.

**17. Termination.** This agreement may be terminated by Seller for any reason and at any time by giving Buyer thirty (30) days written notice of termination. In addition, Seller may

by written notice immediately terminate this agreement for the following: (a) Buyer commits a breach of any provision of this agreement (b) the appointment of a trustee, receiver or custodian for all or any part of Buyer's property (c) the filing of a petition for relief in bankruptcy of the other Party on its own behalf, or by a third party (d) an assignment for the benefit of creditors, or (e) the dissolution or liquidation of the Buyer.

**18. Governing Law.** This agreement and the sale and delivery of all Products hereunder shall be deemed to have taken place in and shall be governed and construed in accordance with the laws of the State of Ohio, as applicable to contracts executed and wholly performed therein and without regard to conflicts of laws principles. Buyer irrevocably agrees and consents to the exclusive jurisdiction and venue of the courts of Cuyahoga County, Ohio with respect to any dispute, controversy or claim arising out of or relating to this agreement. Disputes between the parties shall not be settled by arbitration unless, after a dispute has arisen, both parties expressly agree in writing to arbitrate the dispute.

**19. Indemnity for Infringement of Intellectual Property Rights.** Seller shall have no liability for infringement of any patents, trademarks, copyrights, trade dress, trade secrets or similar rights except as provided in this Section. Seller will defend and indemnify Buyer against allegations of infringement of U.S. patents, U.S. trademarks, copyrights, trade dress and trade secrets ("Intellectual Property Rights"). Seller will defend at its expense and will pay the cost of any settlement or damages awarded in an action brought against Buyer based on an allegation that a Product sold pursuant to this Agreement infringes the Intellectual Property Rights of a third party. Seller's obligation to defend and indemnify Buyer is contingent on Buyer notifying Seller within ten (10) days after Buyer becomes aware of such allegations of infringement, and Seller having sole control over the defense of any allegations or actions including all negotiations for settlement or compromise. If a Product is subject to a claim that it infringes the Intellectual Property Rights of a third party, Seller may, at its sole expense and option, procure for Buyer the right to continue using the Product, replace or modify the Product so as to make it noninfringing, or offer to accept return of the Product and return the purchase price less a reasonable allowance for depreciation. Notwithstanding the foregoing, Seller shall have no liability for claims of infringement based on information provided by Buyer, or directed to Products delivered hereunder for which the designs are specified in whole or part by Buyer, or infringements resulting from the modification, combination or use in a system of any Product sold hereunder. The foregoing provisions of this Section shall constitute Seller's sole and exclusive liability and Buyer's sole and exclusive remedy for infringement of Intellectual Property Rights.

**20. Taxes.** Unless otherwise indicated, all prices and charges are exclusive of excise, sales, use, property, occupational or like taxes which may be imposed by any taxing authority upon the manufacture, sale or delivery of Products.

**21. Equal Opportunity Clause.** For the performance of government contracts and where dollar value of the Products exceed \$10,000, the equal employment opportunity clauses in Executive Order 11246, VEVRAA, and 41 C.F.R. §§ 60-1.4(a), 60-741.5(a), and 60-250.4, are hereby incorporated.





# Parker's Motion & Control Technologies

At Parker, we're guided by a relentless drive to help our customers become more productive and achieve higher levels of profitability by engineering the best systems for their requirements. It means looking at customer applications from many angles to find new ways to create value. Whatever the motion and control technology need, Parker has the experience, breadth of product and global reach to consistently deliver. No company knows more about motion and control technology than Parker. For further info call 1-800-C-Parker.



## AEROSPACE

### Key Markets

- Aircraft engines
- Business & general aviation
- Commercial transports
- Land-based weapons systems
- Military aircraft
- Missiles & launch vehicles
- Regional transports
- Unmanned aerial vehicles

### Key Products

- Flight control systems & components
- Fluid conveyance systems
- Fluid metering delivery & atomization devices
- Fuel systems & components
- Hydraulic systems & components
- Inert nitrogen generating systems
- Pneumatic systems & components
- Wheels & brakes



## CLIMATE CONTROL

### Key Markets

- Agriculture
- Air conditioning
- Food, beverage & dairy
- Life sciences & medical
- Precision cooling
- Processing
- Transportation

### Key Products

- CO<sub>2</sub> controls
- Electronic controllers
- Filter driers
- Hand shut-off valves
- Hose & fittings
- Pressure regulating valves
- Refrigerant distributors
- Safety relief valves
- Solenoid valves
- Thermostatic expansion valves

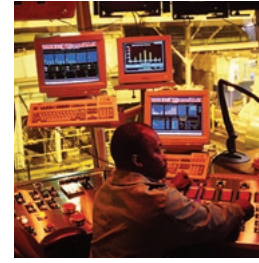

## ELECTROMECHANICAL

### Key Markets

- Aerospace
- Factory automation
- Life science & medical
- Machine tools
- Packaging machinery
- Paper machinery
- Plastics machinery & converting
- Primary metals
- Semiconductor & electronics
- Textile
- Wire & cable

### Key Products

- AC/DC drives & systems
- Electric actuators, gantry robots & slides
- Electrohydraulic actuation systems
- Electromechanical actuation systems
- Human machine interface
- Linear motors
- Stepper motors, servo motors, drives & controls
- Structural extrusions



## FILTRATION

### Key Markets

- Food & beverage
- Industrial machinery
- Life sciences
- Marine
- Mobile equipment
- Oil & gas
- Power generation
- Process
- Transportation

### Key Products

- Analytical gas generators
- Compressed air & gas filters
- Condition monitoring
- Engine air, fuel & oil filtration & systems
- Hydraulic, lubrication & coolant filters
- Process, chemical, water & microfiltration filters
- Nitrogen, hydrogen & zero air generators



## FLUID & GAS HANDLING

### Key Markets

- Aerospace
- Agriculture
- Bulk chemical handling
- Construction machinery
- Food & beverage
- Fuel & gas delivery
- Industrial machinery
- Mobile
- Oil & gas
- Transportation
- Welding

### Key Products

- Brass fittings & valves
- Diagnostic equipment
- Fluid conveyance systems
- Industrial hose
- PTFE & PFA hose, tubing & plastic fittings
- Rubber & thermoplastic hose & couplings
- Tube fittings & adapters
- Quick disconnects



## HYDRAULICS

### Key Markets

- Aerospace
- Aerial lift
- Agriculture
- Construction machinery
- Forestry
- Industrial machinery
- Mining
- Oil & gas
- Power generation & energy
- Truck hydraulics

### Key Products

- Diagnostic equipment
- Hydraulic cylinders & accumulators
- Hydraulic motors & pumps
- Hydraulic systems
- Hydraulic valves & controls
- Power take-offs
- Rubber & thermoplastic hose & couplings
- Tube fittings & adapters
- Quick disconnects

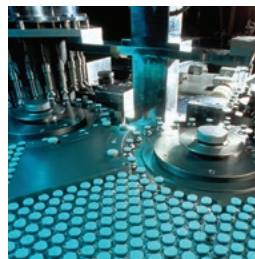

## PNEUMATICS

### Key Markets

- Aerospace
- Conveyor & material handling
- Factory automation
- Life science & medical
- Machine tools
- Packaging machinery
- Transportation & automotive

### Key Products

- Air preparation
- Brass fittings & valves
- Manifolds
- Pneumatic accessories
- Pneumatic actuators & grippers
- Pneumatic valves & controls
- Quick disconnects
- Rotary actuators
- Rubber & thermoplastic hose & couplings
- Structural extrusions
- Thermoplastic tubing & fittings
- Vacuum generators, cups & sensors



## PROCESS CONTROL

### Key Markets

- Chemical & refining
- Food, beverage & dairy
- Medical & dental
- Microelectronics
- Oil & gas
- Power generation

### Key Products

- Analytical sample conditioning products & systems
- Fluoropolymer chemical delivery fittings, valves & pumps
- High purity gas delivery fittings, valves & regulators
- Instrumentation fittings, valves & regulators
- Medium pressure fittings & valves
- Process control manifolds



## SEALING & SHIELDING

### Key Markets

- Aerospace
- Chemical processing
- Consumer
- Energy, oil & gas
- Fluid power
- General industrial
- Information technology
- Life sciences
- Military
- Semiconductor
- Telecommunications
- Transportation

### Key Products

- Dynamic seals
- Elastomeric o-rings
- EMI shielding
- Extruded & precision-cut, fabricated elastomeric seals
- Homogeneous & inserted elastomeric shapes
- High temperature metal seals
- Metal & plastic retained composite seals
- Thermal management



ENGINEERING YOUR SUCCESS.



# Parker Worldwide

## Europe, Middle East, Africa

**AE – United Arab Emirates,**  
Dubai  
Tel: +971 4 8127100  
parker.me@parker.com

**AT – Austria,** Wiener Neustadt  
Tel: +43 (0)2622 23501-0  
parker.austria@parker.com

**AT – Eastern Europe,** Wiener  
Neustadt  
Tel: +43 (0)2622 23501 900  
parker.easteurope@parker.com

**AZ – Azerbaijan,** Baku  
Tel: +994 50 2233 458  
parker.azerbaijan@parker.com

**BE/LU – Belgium,** Nivelles  
Tel: +32 (0)67 280 900  
parker.belgium@parker.com

**BG – Bulgaria,** Sofia  
Tel: +359 2 980 1344  
parker.bulgaria@parker.com

**BY – Belarus,** Minsk  
Tel: +375 17 209 9399  
parker.belarus@parker.com

**CH – Switzerland,** Etoy  
Tel: +41 (0)21 821 87 00  
parker.switzerland@parker.com

**CZ – Czech Republic,** Klecany  
Tel: +420 284 083 111  
parker.czechrepublic@parker.com

**DE – Germany,** Kaarst  
Tel: +49 (0)2131 4016 0  
parker.germany@parker.com

**DK – Denmark,** Ballerup  
Tel: +45 43 56 04 00  
parker.denmark@parker.com

**ES – Spain,** Madrid  
Tel: +34 902 330 001  
parker.spain@parker.com

**FI – Finland,** Vantaa  
Tel: +358 (0)20 753 2500  
parker.finland@parker.com

**FR – France,** Contamine s/Arve  
Tel: +33 (0)4 50 25 80 25  
parker.france@parker.com

**GR – Greece,** Athens  
Tel: +30 210 933 6450  
parker.greece@parker.com

**HU – Hungary,** Budaörs  
Tel: +36 23 885 470  
parker.hungary@parker.com

**IE – Ireland,** Dublin  
Tel: +353 (0)1 466 6370  
parker.ireland@parker.com

**IT – Italy,** Corsico (MI)  
Tel: +39 02 45 19 21  
parker.italy@parker.com

**KZ – Kazakhstan,** Almaty  
Tel: +7 7273 561 000  
parker.easteurope@parker.com

**NL – The Netherlands,** Oldenzaal  
Tel: +31 (0)541 585 000  
parker.nl@parker.com

**NO – Norway,** Asker  
Tel: +47 66 75 34 00  
parker.norway@parker.com

**PL – Poland,** Warsaw  
Tel: +48 (0)22 573 24 00  
parker.poland@parker.com

**PT – Portugal,** Leca da Palmeira  
Tel: +351 22 999 7360  
parker.portugal@parker.com

**RO – Romania,** Bucharest  
Tel: +40 21 252 1382  
parker.romania@parker.com

**RU – Russia,** Moscow  
Tel: +7 495 645-2156  
parker.russia@parker.com

**SE – Sweden,** Spånga  
Tel: +46 (0)8 59 79 50 00  
parker.sweden@parker.com

**SK – Slovakia,** Banská Bystrica  
Tel: +421 484 162 252  
parker.slovakia@parker.com

**SL – Slovenia,** Novo Mesto  
Tel: +386 7 337 6650  
parker.slovenia@parker.com

**TR – Turkey,** Istanbul  
Tel: +90 216 4997081  
parker.turkey@parker.com

**UA – Ukraine,** Kiev  
Tel: +380 44 494 2731  
parker.ukraine@parker.com

**UK – United Kingdom,** Warwick  
Tel: +44 (0)1926 317 878  
parker.uk@parker.com

**ZA – South Africa,** Kempton Park  
Tel: +27 (0)11 961 0700  
parker.southafrica@parker.com

## North America

**CA – Canada,** Milton, Ontario  
Tel: +1 905 693 3000

**US – USA,** Cleveland  
Tel: +1 216 896 3000

## Asia Pacific

**AU – Australia,** Castle Hill  
Tel: +61 (0)2-9634 7777

**CN – China,** Shanghai  
Tel: +86 21 2899 5000

**HK – Hong Kong**  
Tel: +852 2428 8008

**IN – India,** Mumbai  
Tel: +91 22 6513 7081-85

**JP – Japan,** Tokyo  
Tel: +81 (0)3 6408 3901

**KR – South Korea,** Seoul  
Tel: +82 2 559 0400

**MY – Malaysia,** Shah Alam  
Tel: +60 3 7849 0800

**NZ – New Zealand,** Mt Wellington  
Tel: +64 9 574 1744

**SG – Singapore**  
Tel: +65 6887 6300

**TH – Thailand,** Bangkok  
Tel: +662 186 7000-99

**TW – Taiwan,** Taipei  
Tel: +886 2 2298 8987

## South America

**AR – Argentina,** Buenos Aires  
Tel: +54 3327 44 4129

**BR – Brazil,** Sao Jose dos Campos  
Tel: +55 800 727 5374

**CL – Chile,** Santiago  
Tel: +56 2 623 1216

**MX – Mexico,** Toluca  
Tel: +52 72 2275 4200

