



***SensoControl®  
Test Points  
Diagnostic-  
Test equipment  
Industrial Products***



Visual index

**Series 1**

Test point fitting with pin-lock

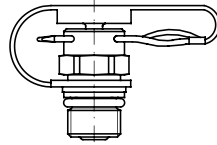

**EMA1**  
p. R4

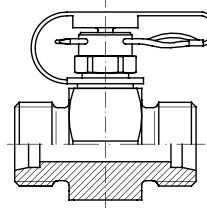

**GMA1**  
p. R5

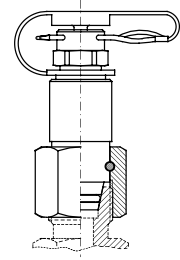

**VKA1**  
p. R6

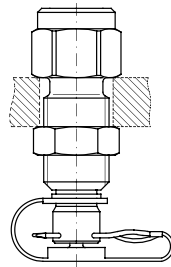

**MAV ... MA1**  
p. R7

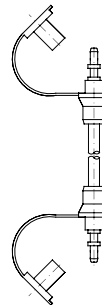

**SMA1**  
p. R7

**Series 3**

Test point with threaded connection  
M 16x2

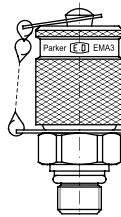

**EMA3**  
p. R8

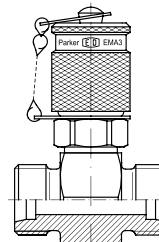

**GMA3**  
p. R9

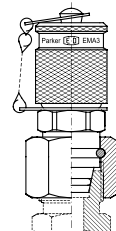

**VKA3**  
p. R10

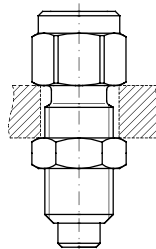

**MAV ... MA3**  
p. R11

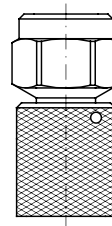

**MAVMD ... MA3**  
p. R11

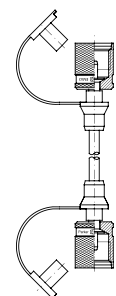

**SMA3**  
p. R11

**SensoControl®**

Product range

Diagnostic/Industrial



p. R12

## EMA1/EMA3-Test Point fitting

- For pressure monitoring and checking on high, low and negative pressure systems.
- For bleeding cylinders and hydraulic systems.
- For taking samples on high, low and negative pressure systems.

### Advantages:

- Leakfree connection before valve is open
- Sturdy, safe constructions for small dimensions
- Easy handling
- Simple connection of measuring, control and switching devices
- Coupling under pressure up to 400 bar is possible with screw couplings
- Nominal pressures up to 630 bar
- Self locking metal guard cap, vibration resistant

### Sealing system of the primary seal:

EMA1 by ball non-return valve.

EMA3 by cone seal with O-ring.

The new EMA3 sealing system guarantees minimum leakage rates.

The screw-on Cap (EMA3), and pin lock (EMA1) types both employ an O-ring seal as secondary sealing with the hose attached.

### Differences between EMA1 and EMA3 types

- a) sealing system (see previous section)
- b) Test hose connection by plug-in coupling in EMA1  
Test hose connection by threaded connection in EMA3
- c) Working pressures (see section advantages)

### Working pressure

- EMA3 types up to 630 bar
- EMA1 types up to 400 bar
- Max. working pressure 630 bar for GMA, VKA and EMA... the recommended working pressure of fitting manufacturer has to be applied
- Joining under pressure up to 400 bar max.
- The allowable nominal pressures of each Test-Point are shown on the product pages.

### Materials and Temperatures:

- Steel, zinc plated, Cr(VI)-free
- Stainless Steel, material 1.4571
- Seals:
- FKM (Temperature range -20 to +200°C)
- EPDM Ethylene Propylene (for Break Fluid) (Temperature range -40 to +150°C)
- Hose:
- Polyamide (Temperature range: -35°C ... 100°C max.)
- Stainless Steel FKM only

### Media:

- Suitable for hydraulic oils and other mineral oil based fluids (Please pay attention to the sealing materials used!)
- For use in conjunction with other liquid media please consult Parker

### Approvals

DVGW for EMA3/8X1OR, EMA3/10X1OR, EMA31/8NPT, EMA31/4NPT

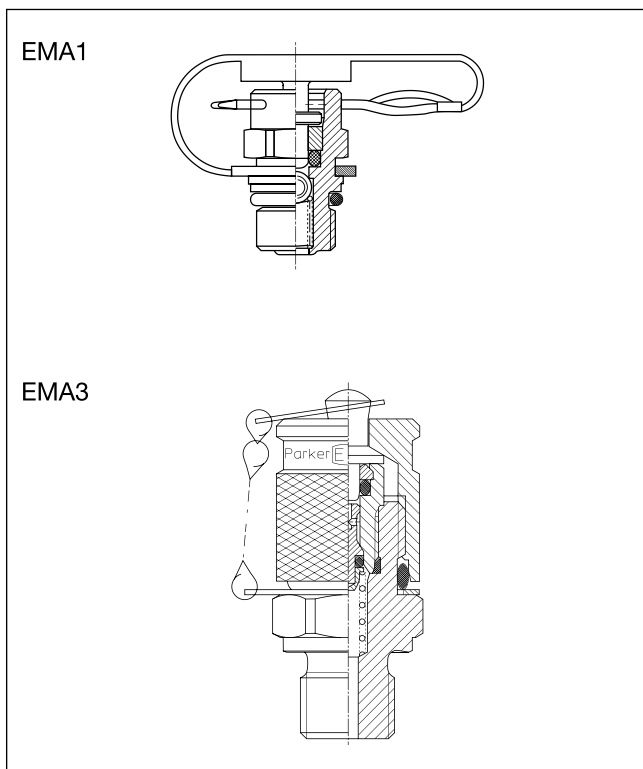

Perbunan = registered trademark of Bayer

**EMA1 Test point fitting with pin-lock**

**Series 1**

Male stud thread: BSP, metric

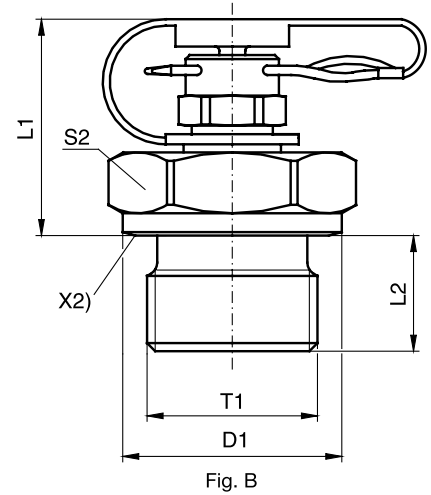
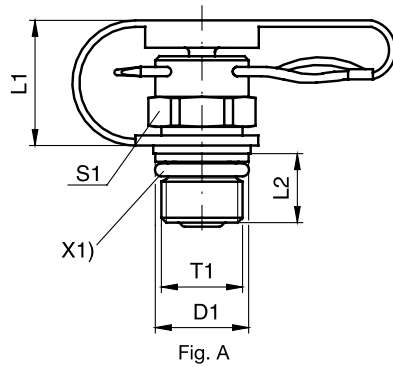

X1) O-ring  
X2) Cutting face

T1	D1	L1	L2	S1	S2	Fig.	Weight g/1 piece	Order code*	PN (bar) <sup>1)</sup> CF	DF**
M 12x1.5	17.0	32.0	12.0		19	B	53	<b>EMA1/12X1.5</b>	400	4
M 14x1.5	19.0	32.0	12.0		19	B	56	<b>EMA1/14X1.5</b>	400	4
M 16x1.5	21.0	25.0	12.0		22	B	47	<b>EMA1/16X1.5</b>	400	4
G 1/8	14.0	32.5	8.0		17	B	41	<b>EMA1/1/8</b>	400	4
G 1/4	18.0	32.0	12.0		19	B	54	<b>EMA1/1/4</b>	400	4
G 3/8	22.0	27.5	12.0		22	B	55	<b>EMA1/3/8</b>	400	4
G 1/2	26.0	27.5	14.0		27	B	78	<b>EMA1/1/2</b>	400	4
M 08x1.0	9.5	17.5	8.4	12		A	16	<b>EMA1/8X1OR</b>	400	4
M 10x1.0	11.5	18.0	8.0	12		A	18	<b>EMA1/10X1OR</b>	400	4
M 10x1.0	14.0	32.5	8.0		17	B	42	<b>EMA1/10X1</b>	400	4

\*\*DF = Design Factor

<sup>1)</sup>Pressure shown = item deliverable

$$\frac{PN \text{ (bar)}}{10} = PN \text{ (MPa)}$$

\*Please add the **suffixes** below according to the material/surface required.

Order code suffixes			
Material	Suffix surface and material	Example	Standard sealing material (no additional suffix needed)
Steel, zinc plated, Cr(VI)-free	CF	EMA1/12X1.5CF	NBR

**GMA1 Straight test point fitting with pin-lock**

**Series 1**

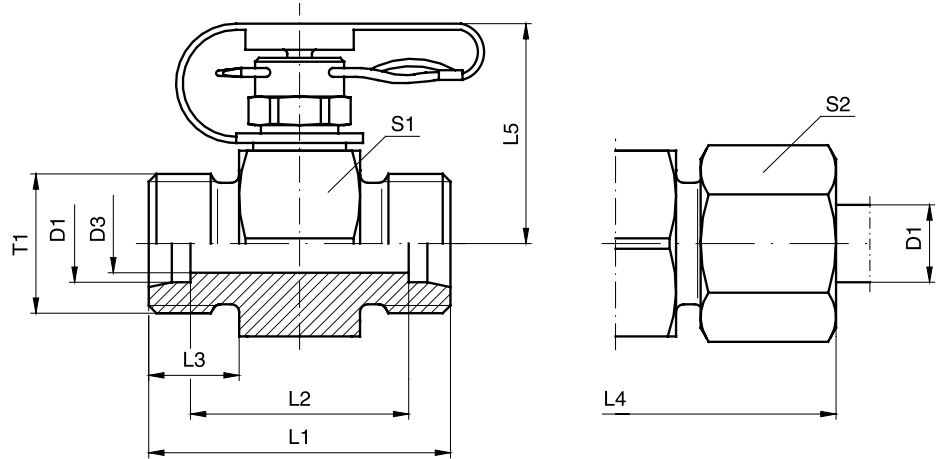

Series	D1	T1	D3	L1	L2	L3	L4	L5	S1	S2	Weight g/1 piece	Order code*	PN (bar) <sup>1)</sup> CF	DF**
L <sup>3)</sup>	06	M 12x1.5	4	35	21	10	51	29.0	24	14	73	<b>GMA1/06LOMD</b>	315	4
	08	M 14x1.5	6	35	21	10	51	29.0	24	17	75	<b>GMA1/08LOMD</b>	315	4
	10	M 16x1.5	7	37	23	11	53	29.0	24	19	80	<b>GMA1/10LOMD</b>	315	4
	12	M 18x1.5	8	37	23	11	53	30.5	24	22	96	<b>GMA1/12LOMD</b>	315	4
	15	M 22x1.5	11	39	25	12	55	32.0	30	27	121	<b>GMA1/15LOMD</b>	315	4
	18	M 26x1.5	14	39	24	12	57	33.0	32	32	139	<b>GMA1/18LOMD</b>	315	4
	22	M 30x2.0	18	43	28	14	61	35.0	36	36	171	<b>GMA1/22LOMD</b>	160	4
S <sup>4)</sup>	06	M 14x1.5	4	39	25	12	55	29.0	24	17	82	<b>GMA1/06SOMD</b>	400	4
	08	M 16x1.5	5	39	25	12	55	29.0	24	19	88	<b>GMA1/08SOMD</b>	400	4
	10	M 18x1.5	7	39	24	12	57	29.0	24	22	90	<b>GMA1/10SOMD</b>	400	4
	12	M 20x1.5	7	39	24	12	57	29.0	24	24	96	<b>GMA1/12SOMD</b>	400	4
	14	M 22x1.5	10	43	27	14	63	30.5	27	27	121	<b>GMA1/14SOMD</b>	400	4
	16	M 24x1.5	11	43	26	14	63	32.0	30	30	138	<b>GMA1/16SOMD</b>	400	4
	20	M 30x2.0	15	47	26	16	69	35.0	36	36	222	<b>GMA1/20SOMD</b>	400	4

\*\*DF = Design Factor

<sup>1)</sup>Pressure shown = item deliverable

<sup>3)</sup>L = light series; <sup>4)</sup>S = heavy series

$$\frac{PN \text{ (bar)}}{10} = PN \text{ (MPa)}$$

Delivery without nut and ring. Information on ordering complete fittings or alternative sealing materials see page I7.



\*Please add the **suffixes** below according to the material/surface required.

Order code suffixes			
Material	Suffix surface and material	Example	Standard sealing material (no additional suffix needed)
Steel, zinc plated, Cr(VI)-free	CF	GMA1/06LOMDCF	NBR



**VKA1 Test point fitting with pin lock for cones** **Series 1**

With 24° cone swivel nut connection

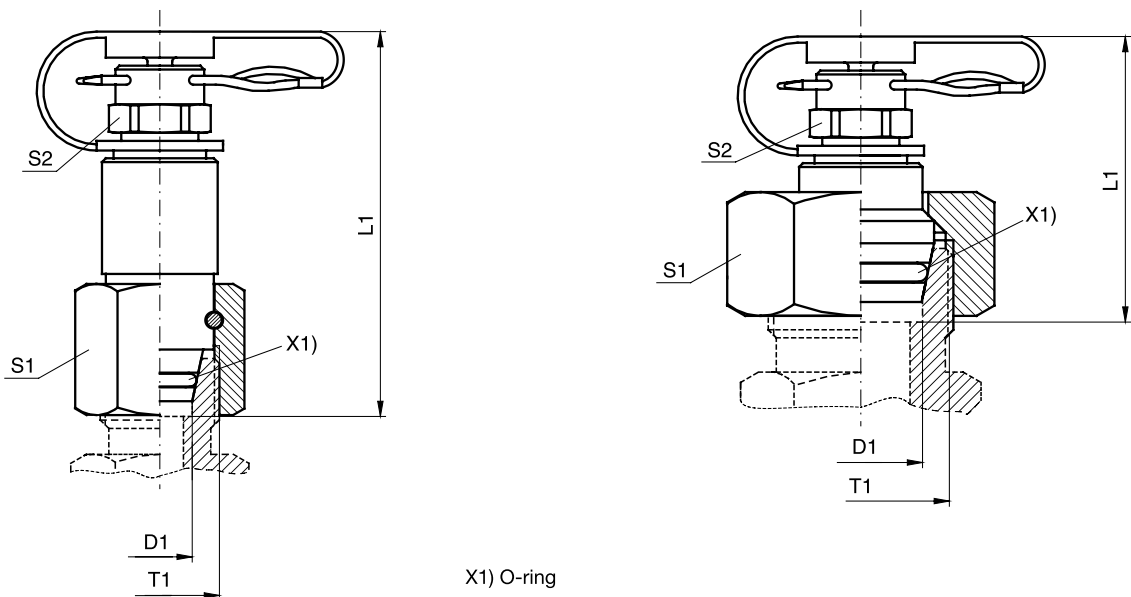

X1) O-ring

Series	D1	T1	L1	S1	S2	Fig.	Weight g/1 piece	Order code*	PN (bar) <sup>1)</sup> CF	DF <sup>2)</sup>
L <sup>3)</sup>	06	M 12x1.5	48	14	12	A	44	<b>VKA1/06L</b>	315	4
	08	M 14x1.5	49	17	12	A	54	<b>VKA1/08L</b>	315	4
	10	M 16x1.5	50	19	12	A	68	<b>VKA1/10L</b>	315	4
	12	M 18x1.5	51	22	12	A	81	<b>VKA1/12L</b>	315	4
	15	M 22x1.5	39	27	12	B	82	<b>VKA1/15L</b>	315	4
	18	M 26x1.5	38	32	12	B	112	<b>VKA1/18L</b>	315	4
S <sup>4)</sup>	06	M 14x1.5	48	17	12	A	51	<b>VKA1/06S</b>	400	4
	08	M 16x1.5	50	19	12	A	62	<b>VKA1/08S</b>	400	4
	10	M 18x1.5	50	22	12	A	78	<b>VKA1/10S</b>	400	4
	12	M 20x1.5	51	24	12	A	100	<b>VKA1/12S</b>	400	4
	14	M 22x1.5	39	27	12	B	88	<b>VKA1/14S</b>	400	4
	16	M 24x1.5	37	30	12	B	105	<b>VKA1/16S</b>	400	4
	20	M 30x2.0	44	36	12	B	174	<b>VKA1/20S</b>	400	4

\*\*DF = Design Factor

<sup>1)</sup>Pressure shown = item deliverable

<sup>3)</sup>L = light series; <sup>4)</sup>S = heavy series

$\frac{PN \text{ (bar)}}{10} = PN \text{ (MPa)}$

\*Please add the **suffixes** below according to the material/surface required.

Order code suffixes			
Material	Suffix surface and material	Example	Standard sealing material (no additional suffix needed)
Steel, zinc plated, Cr(VI)-free	CF	VKA1/06LCF	NBR



**MAV-MA1 Test Point pressure gauge connector with pin-lock**  
**SMA1 Test Point high pressure hose with pin-lock**

**Series 1**

Female thread: BSP  
 Sealing: sealing ring DIN 16258

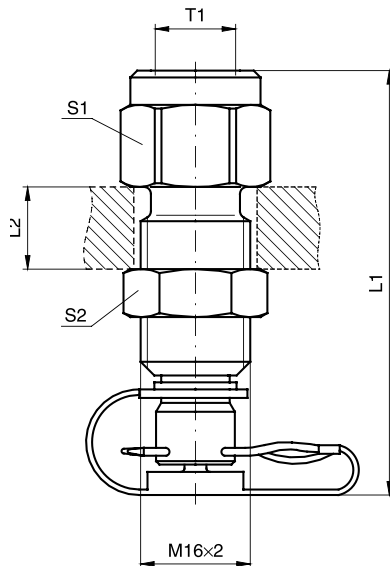

Pressure gauge connector: MAV-MA1

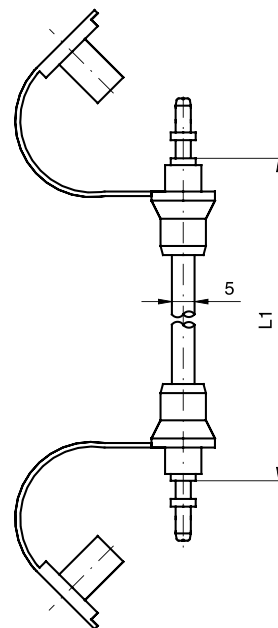

Test hose: SMA1

T1	L1	L2 max.	S1	S2	Weight g/1 piece	Order code*	PN (bar) <sup>1)</sup> CF	DF**
G 1/4	61.5	12	19	19	78	<b>MAV1/4MA1</b>	400	4.0
G 1/2	72.0	12	27	19	135	<b>MAV1/2MA1</b>	400	4.0
	400.0				21	<b>SMA1-400</b>	400	2.5
	630.0				26	<b>SMA1-630</b>	400	2.5
	800.0				26	<b>SMA1-800</b>	400	2.5
	1000.0				31	<b>SMA1-1000</b>	400	2.5
	1500.0				40	<b>SMA1-1500</b>	400	2.5
	2000.0				49	<b>SMA1-2000</b>	400	2.5
	2500.0				58	<b>SMA1-2500</b>	400	2.5
	3200.0				70	<b>SMA1-3200</b>	400	2.5
	4000.0				84	<b>SMA1-4000</b>	400	2.5

\*\*DF = Design Factor

<sup>1)</sup>Pressure shown = item deliverable

$$\frac{PN(\text{bar})}{10} = PN(\text{MPa})$$

\*Please add the **suffixes** below according to the material/surface required.

Order code suffixes			
Material	Suffix surface and material	Example	Standard sealing material (no additional suffix needed)
Steel, zinc plated, Cr(VI)-free	CF	MAV1/4MA1CF	NBR

**Note hoses with small diameter:**

- Min. bending radius  $r = 20$  mm
- Working temperature  $-20$  °C up to  $100$  °C (short time to  $+120$  °C)
- Hoses are to be protected from fire, from sharp-corners and hot objects.

For measuring with liquid pressure media please note:  
 Bleed before connecting tube! By capillary action discharge of the pressure medium is prevented widely.

Temperature factor of pressure rating:

up to 0 °C	122 %
for 30 °C	110 %
for 50 °C	100 %
for 80 °C	86 %
for 100 °C	77 %



EMA3 Test Point with threaded connection M 16×2

Series 3

Male thread: BSP, metric

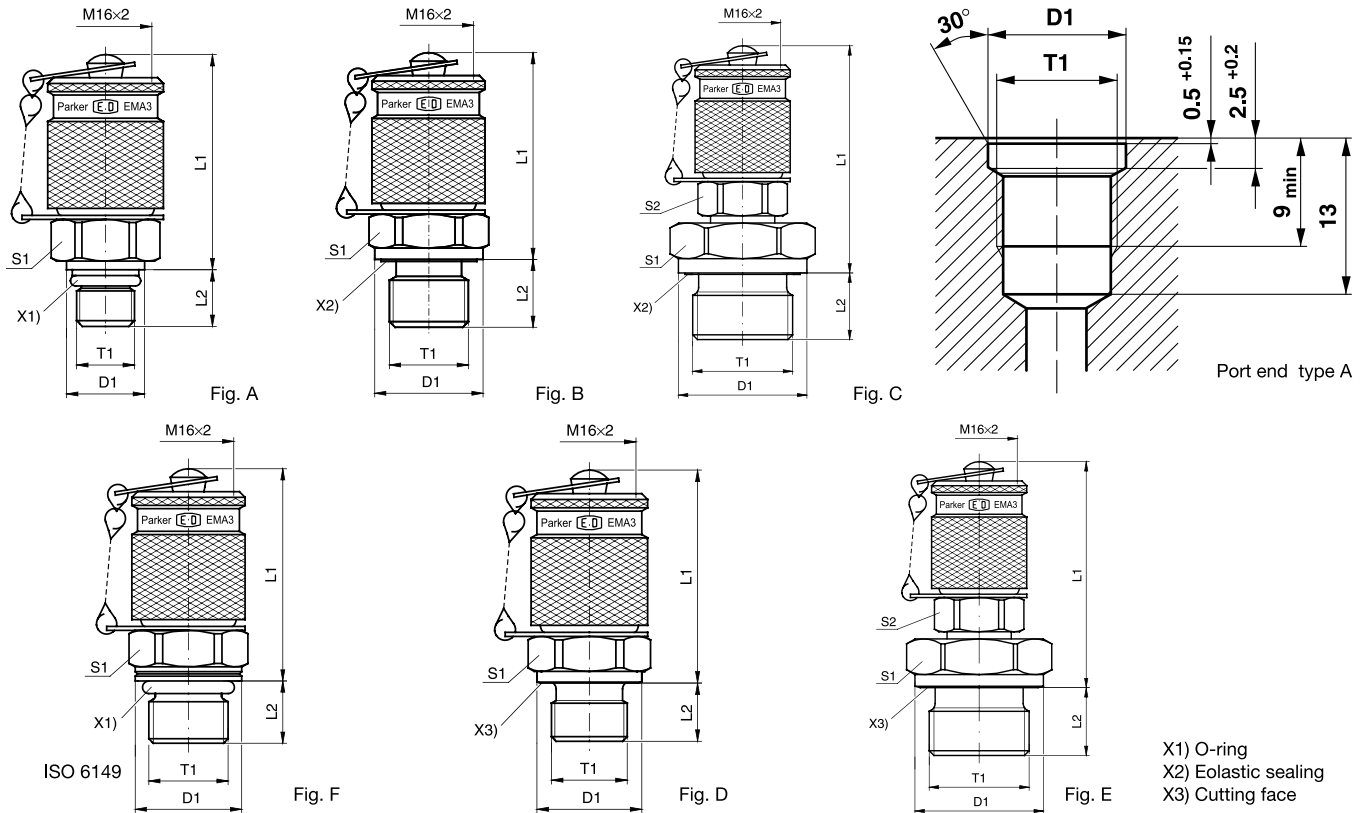

T1	D1	L1	L2	S1	S2	Fig.	Weight g/1 piece	Order code*	PN (bar) <sup>1)</sup>		DF**	
									CF	71	CF	71
M 08×1.0	9.5	38.5	7.5	17		A	66	<b>EMA3/8X1OR</b>	250		4.0	
M 10×1.0	11.5	37.0	7.5	17		A	70	<b>EMA3/10X1OR</b>	630	630	4.0	4
M 14×1.5	18.8	39.5	11.0	19		F	79	<b>EMA3/14X1.5ISO</b>	630	630	4.0	4
M 10×1.0	14.0	40.0	8.0	17		D	67	<b>EMA3/10X1</b>	400		4.0	
M 12×1.5	17.0	38.0	12.0	17		D	74	<b>EMA3/12X1.5</b>	400		4.0	
M 14×1.5	19.0	39.0	12.0	19		D	78	<b>EMA3/14X1.5</b>	400		4.0	
M 16×1.5	21.0	40.0	12.0	22		D	90	<b>EMA3/16X1.5</b>	400		4.0	
G 1/8	14.0	37.5	8.0	17		D	70	<b>EMA3/1/8</b>	400		4.0	
G 1/4	18.0	39.0	12.0	19		D	77	<b>EMA3/1/4</b>	400		4.0	
G 3/8	22.0	40.5	12.0	22		D	91	<b>EMA3/3/8</b>	400		4.0	
G 1/2	26.0	46.0	14.0	27	17	E	137	<b>EMA3/1/2</b>	400		3.4	
G 1/8	14.0	37.5	8.0	17		B	72	<b>EMA3/1/8ED</b>	400	400	4.0	4
G 1/4	19.0	39.0	12.0	19		B	76	<b>EMA3/1/4ED***</b>	630	630	4.0	4
G 3/8	22.0	40.5	12.0	22		B	93	<b>EMA3/3/8ED</b>	630	630	4.0	4
M 10×1.0	14.0	40.0	8.0	17		B	71	<b>EMA3/10X1ED</b>	400	400	4.0	4
M 12×1.5	17.0	38.0	12.0	17		B	72	<b>EMA3/12X1.5ED</b>	630	630	4.0	4
M 14×1.5	19.0	39.0	12.0	19		B	77	<b>EMA3/14X1.5ED</b>	400	400	4.0	4
G 1/2	27.0	46.0	14.0	27	17	C	135	<b>EMA3/1/2ED</b>	400	400	4.0	4

\*\*DF = Design Factor  
\*\*\*in 316L

<sup>1)</sup>Pressure shown = item deliverable

PN (bar)  
10 = PN (MPa)

\*Please add the suffixes below according to the material/surface required.

Order code suffixes			
Material	Suffix surface and material	Example	Standard sealing material (no additional suffix needed)
Steel, zinc plated, Cr(VI)-free	CF	EMA3/10X10ORCF	NBR
Stainless Steel	71	EMA3/10X10OR71	VIT
Stainless Steel	316L	EMA3/1/4ED316L	NBR





**GMA3 Straight Test Point with threaded connection M 16×2**

**Series 3**

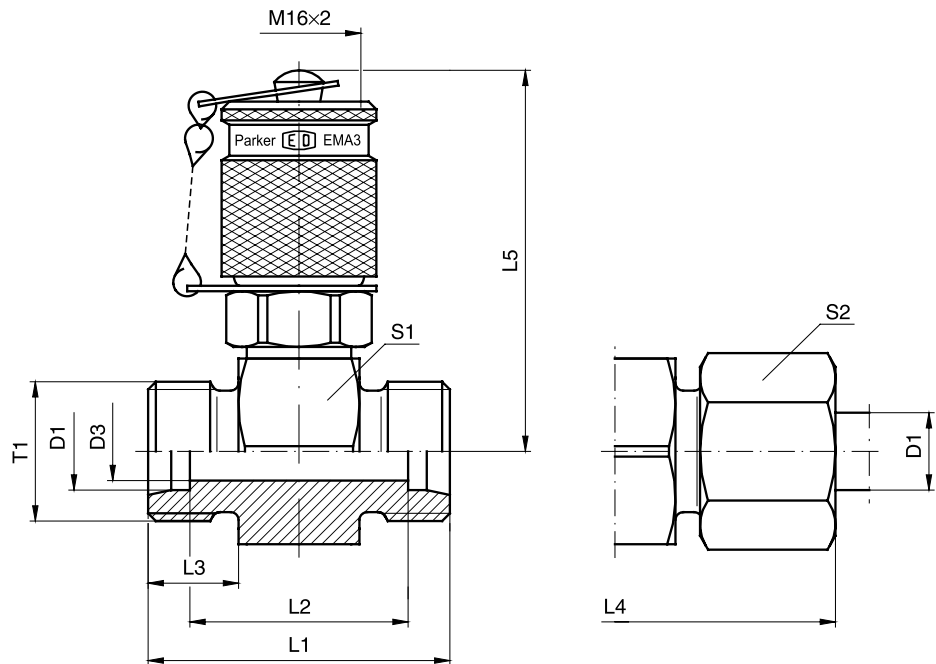

Series	D1	T1	D3	L1	L2	L3	L4	L5	S1	S2	Weight g/1 piece	Order code*	PN (bar) <sup>1)</sup>		DF**	
													CF	71	CF	71
L <sup>3)</sup>	06	M 12×1.5	4	35	21	10	51	49.0	24	14	126	<b>GMA3/06LOMD</b>	315	315	4	4
	08	M 14×1.5	6	35	21	10	51	49.0	24	17	128	<b>GMA3/08LOMD</b>	315	315	4	4
	10	M 16×1.5	7	37	23	11	53	49.0	24	19	132	<b>GMA3/10LOMD</b>	315	315	4	4
	12	M 18×1.5	8	37	23	11	53	50.5	27	22	145	<b>GMA3/12LOMD</b>	315	315	4	4
	15	M 22×1.5	11	39	25	12	55	52.0	30	27	174	<b>GMA3/15LOMD</b>	315	315	4	4
	18	M 26×1.5	14	39	24	12	57	53.0	32	32	192	<b>GMA3/18LOMD</b>	315	315	4	4
	22	M 30×2.0	18	43	28	14	61	55.0	36	36	220	<b>GMA3/22LOMD</b>	160	160	4	4
	28	M 36×2.0	23	43	28	14	61	57.5	41	41	259	<b>GMA3/28LOMD</b>	160	160	4	4
	35	M 45×2.0	30	47	26	16	69	60.0	46	50	363	<b>GMA3/35LOMD</b>	160	160	4	4
	42	M 52×2.0	36	47	25	16	71	64.5	55	60	419	<b>GMA3/42LOMD</b>	160	160	4	4
S <sup>4)</sup>	06	M 14×1.5	4	39	25	12	55	49.0	24	17	137	<b>GMA3/06SOMD</b>	630	630	4	4
	08	M 16×1.5	5	39	25	12	55	49.0	24	19	141	<b>GMA3/08SOMD</b>	630	630	4	4
	10	M 18×1.5	7	39	24	12	57	49.0	24	22	141	<b>GMA3/10SOMD</b>	630	630	4	4
	12	M 20×1.5	7	39	24	12	57	49.0	24	24	150	<b>GMA3/12SOMD</b>	630	630	4	4
	14	M 22×1.5	10	43	27	14	63	50.5	27	27	172	<b>GMA3/14SOMD</b>	630	630	4	4
	16	M 24×1.5	11	43	26	14	63	52.0	30	30	195	<b>GMA3/16SOMD</b>	400	400	4	4
	20	M 30×2.0	15	47	26	16	69	55.0	36	36	254	<b>GMA3/20SOMD</b>	400	400	4	4
	25	M 36×2.0	20	51	27	18	75	57.5	41	46	329	<b>GMA3/25SOMD</b>	400	400	4	4
	30	M 42×2.0	25	55	28	20	81	60.0	46	50	412	<b>GMA3/30SOMD</b>	400	400	4	4
	38	M 52×2.0	32	61	29	22	91	64.5	55	60	616	<b>GMA3/38SOMD</b>	315	315	4	4

\*\*DF = Design Factor

<sup>1)</sup>Pressure shown = item deliverable

<sup>3)</sup>L = light series; <sup>4)</sup>S = heavy series

$$\frac{PN \text{ (bar)}}{10} = PN \text{ (MPa)}$$

Delivery without nut and ring.

Information on ordering complete fittings or alternative sealing materials see page 17.

\*Please add the suffixes below according to the material/surface required.

Order code suffixes			
Material	Suffix surface and material	Example	Standard sealing material (no additional suffix needed)
Steel, zinc plated, Cr(VI)-free	CF	GMA3/06LOMDCF	NBR
Stainless Steel	71	GMA3/06LOMD71	VIT



**VKA3 Test Point for cones with threaded connection M 16×2**

**Series 3**

With 24° cone swivel nut connection

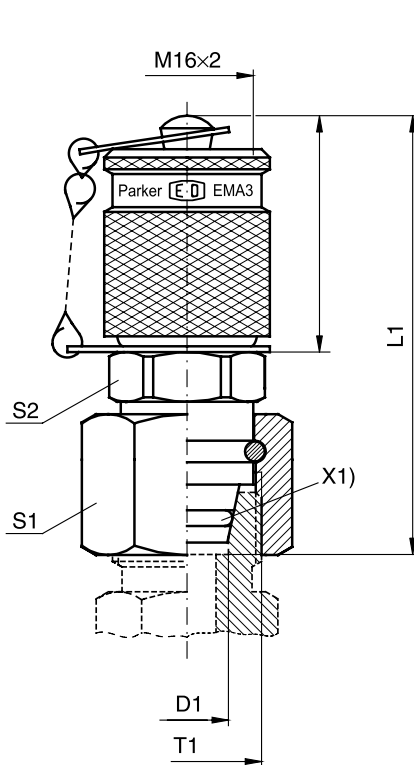

Fig. A

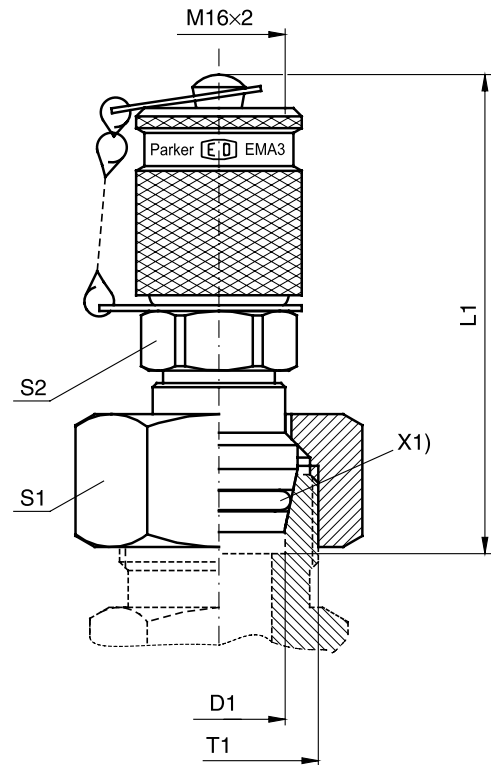

Fig. B

X1) O-ring

Series	D1	T1	L1	S1	S2	Fig.	Weight g/1 piece	Order code*	PN (bar) <sup>1)</sup>		DF**	
									CF	71	CF	71
L <sup>3)</sup>	06	M 12×1.5	55	14	17	A	82	<b>VKA3/06L</b>	315	315	4	4
	08	M 14×1.5	51	17	17	A	82	<b>VKA3/08L</b>	315	315	4	4
	10	M 16×1.5	53	19	17	A	93	<b>VKA3/10L</b>	315	315	4	4
	12	M 18×1.5	53	22	17	A	107	<b>VKA3/12L</b>	315	315	4	4
	15	M 22×1.5	59	27	17	B	133	<b>VKA3/15L</b>	315	315	4	4
	18	M 26×1.5	59	32	17	B	163	<b>VKA3/18L</b>	315	315	4	4
	22	M 30×2.0	60	36	17	B	205	<b>VKA3/22L</b>	160	160	4	4
	28	M 36×2.0	64	41	17	B	269	<b>VKA3/28L</b>	160	160	4	4
	35	M 45×2.0	71	50	17	B	411	<b>VKA3/35L</b>	160	160	4	4
	42	M 52×2.0	72	60	17	B	592	<b>VKA3/42L</b>	160	160	4	4
S <sup>4)</sup>	06	M 14×1.5	50	17	17	A	81	<b>VKA3/06S</b>	630	630	4	4
	08	M 16×1.5	52	19	17	A	88	<b>VKA3/08S</b>	630	630	4	4
	10	M 18×1.5	53	22	17	A	99	<b>VKA3/10S</b>	630	630	4	4
	12	M 20×1.5	54	24	19	A	121	<b>VKA3/12S</b>	630	630	4	4
	14	M 22×1.5	59	27	17	B	136	<b>VKA3/14S</b>	630	630	4	4
	16	M 24×1.5	58	30	17	B	156	<b>VKA3/16S</b>	400	400	4	4
	20	M 30×2.0	65	36	17	B	223	<b>VKA3/20S</b>	400	400	4	4
	25	M 36×2.0	68	46	17	B	367	<b>VKA3/25S</b>	400	400	4	4
	30	M 42×2.0	74	50	17	B	444	<b>VKA3/30S</b>	400	400	4	4
	38	M 52×2.0	81	60	17	B	655	<b>VKA3/38S</b>	315	315	4	4

\*\*DF = Design Factor

<sup>1)</sup> Pressure shown = item deliverable

<sup>3)</sup> L = light series; <sup>4)</sup> S = heavy series

PN (bar)  
10 = PN (MPa)

\*Please add the **suffixes**  
below according to the material/  
surface required.

Order code suffixes			
Material	Suffix surface and material	Example	Standard sealing material (no additional suffix needed)
Steel, zinc plated, Cr(VI)-free	CF	VKA3/06LCF	NBR
Stainless Steel	71	VKA3/06L71	VIT



**MAV...MA3 Test point pressure gauge connector with threaded connection M 16×2**  
**MAVMD...MA3 Test point with threaded connection M 16×2**  
**SMA3 Test point high pressure hose with threaded connection M 16×2 Series 3**

Female thread: BSP  
 Sealing: sealing ring DIN 16258\*

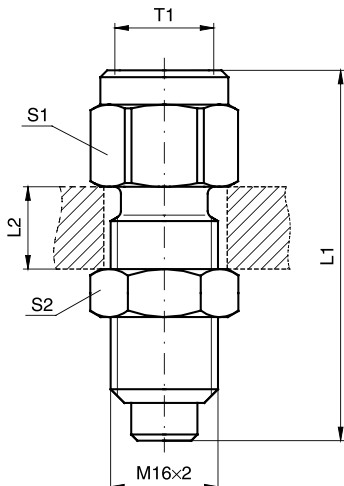

Pressure gauge connector:  
**MAV...MA3**

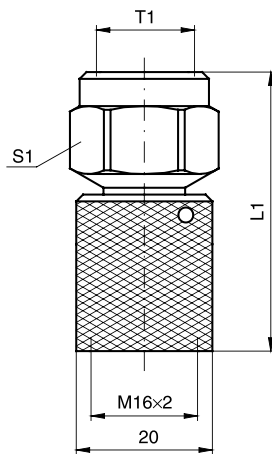

Gauge-Direct-Connector:  
**MAVMD...MA3**

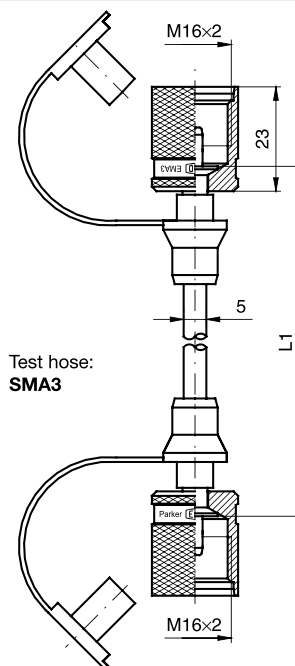

Test hose:  
**SMA3**

T1	L1	L2 max.	S1	S2	Weight g/1 piece	Order code*	PN (bar)1) CF	DF**
G 1/4	54.0	12	19	19	74	<b>MAV1/4MA3</b>	630	4.0
G 1/2	64.0	12	27	19	129	<b>MAV1/2MA3</b>	630	4.0
G 1/4	41.0		19		61	<b>MAVMD1/4MA3</b>	630	4.0
G 1/2	51.5		27		103	<b>MAVMD1/2MA3</b>	630	4.0
	200.0				73	<b>SMA3-200</b>	630	2.5
	300.0				74	<b>SMA3-300</b>	630	2.5
	400.0				74	<b>SMA3-400</b>	630	2.5
	630.0				79	<b>SMA3-630</b>	630	2.5
	800.0				83	<b>SMA3-800</b>	630	2.5
	1000.0				87	<b>SMA3-1000</b>	630	2.5
	1500.0				95	<b>SMA3-1500</b>	630	2.5
	2000.0				105	<b>SMA3-2000</b>	630	2.5
	2500.0				110	<b>SMA3-2500</b>	630	2.5
	3200.0				125	<b>SMA3-3200</b>	630	2.5
	4000.0				137	<b>SMA3-4000</b>	630	2.5

\*\*DF = Design Factor

1) Pressure shown = item deliverable

PN (bar) / 10 = PN (MPa)

\*Please add the **suffixes** below according to the material/ surface required.

Order code suffixes			
Material	Suffix surface and material	Example	Standard sealing material (no additional suffix needed)
Steel, zinc plated, Cr(VI)-free	CF	MAV1/4MA3CF	NBR

\* Sealing rings according to DIN 16258 for steel design of copper, for stainless steel design of stainless steel.

**Note hoses with small diameter:**

- Min. bending radius r = 20 mm
- Working temperature -20 °C up to 100 °C (short time to +120 °C)
- Hoses are to be protected from fire, from sharp-corners and hot objects.

For measuring with liquid pressure media please note:  
 Bleed before connecting tube! By capillary action discharge of the pressure medium is prevented widely.

Temperature factor of pressure rating:

up to 0 °C	122 %
for 30 °C	110 %
for 50 °C	100 %
for 80 °C	86 %
for 100 °C	77 %



### ServiceJunior



The **ServiceJunior** enables the measurement and display of pressures in a single device. Thanks to the four-digit display, the measurement values are displayed more accurately. Pressure peaks are securely recorded with a sampling rate of 10 ms.

The **ServiceJunior** is characterized by its easy use. With its convincing price-performance ratio, the device offers all the advantages of digital pressure measurement. The measurement of MIN and MAX values enables pressure peaks to be recorded.

#### Device features:

- Digital pressure measurement and backlit display
- Accuracy  $\pm 0.1-0.5\%$  FS (FullScale)
- Display with a bar chart (drag indicator) using the peak hold function
- Pressure peak measurement with 10 ms sampling rate
- Easy operation
- Robust and reliable
- Rotating

### Parker Serviceman Plus



The new **Parker Serviceman Plus** is a mobile, extremely robust and easy-to-use measurement instrument for numerous measurement tasks in mobile hydraulics and stationary hydraulic plants.

Thanks to the automatic sensor recognition, you can simply clip in pressure, temperature, flow rate and speed sensors and start measurements immediately. No tedious sensor parameterizing required, the measuring ranges are automatically scaled and the measurement unit is shown in the display.

#### Device features:

- Easy operation
- Robust design with oil-resistant rubber protection
- Plug-&-Play functionality
- Large back-lit display
- New storage concept with a Nano USB stick
- Incl. PC software SensoWin®
- Can be delivered in 2 versions: analog or CAN

## The Parker Service Master *Easy*



The Parker Service Master *Easy* is a multi-channel portable measurement instrument for the simultaneous measurement of important hydraulic units:

It can measure, display, store and process all hydraulic parameters such as pressure, differential pressure, temperature, rotation speed, flow rate and hydraulic performance.

In order to meet the requirements of both modern industry hydraulics and complex mobile hydraulics, different versions are available to the user.

### Device features:

- 3-channel and 4-channel versions
- Easy to use thanks to automatic sensor recognition
- PC connection
- Measuring channels
- Integrated memory
- Trigger storage
- Incl. PC software SensoWin®

## The Parker Service Master *Plus*



In machine, plant and vehicle construction, the implementation possibilities of hydraulics are constantly increasing through the combination of hydraulics and electronics. The Parker Service Master *Plus* meets the demands of this development. It has never been easier to measure, display and analyze complex processes. The tried and tested storage process is particularly targeted at the measurement of MIN and MAX values and, in combination with various display options, offers analysis possibilities for problem solving.

### Device features:

- Portable multi-function measuring instrument
- Measure, monitor and analyze pressure, temperature, volumetric flow rate and rotation speed.
- Measurements and displays from 26 sensors
- Presentation of measurement values as figures, bars, pointer and curves
- Project templates stored and loaded
- Interfaces: CAN, LAN, USB
- Storage of all measurement values for more than 1 billion values.
- Measurement data (automated recording, storage and analysis via LAN and USB with PC software SensoWin®)

Catalogue 4054

Catalogue 4054

### PC software SensoWin®

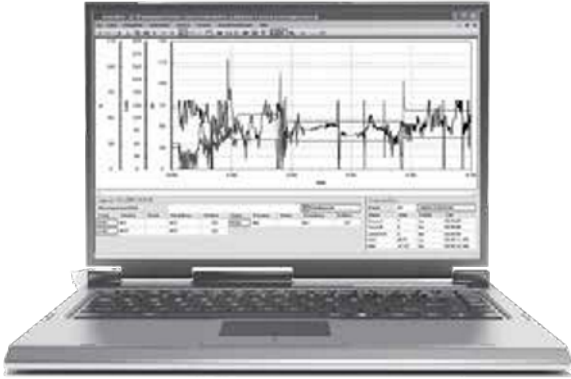

PC software **SensoWin®** is an easy-to-use aid for importing and editing the measurement curves recorded by the **Parker Serviceman Plus**, **The Parker Service Master Easy** or **The Parker Service Master Plus**.

Documentation and certificates are easily and cheaply issued, as PC software **SensoWin®** can serve all possibilities and advantages of Windows.

#### Device features:

- Easy operation
- Compatible with Windows 2000/XP/VISTA/7 (32- und 64-bit)
- Zoom function
- Conjunction of measurement curves
- Tabular view of measurement values
- Calculation of extreme values
- Cursor function
- Transmission of measurement procedures and documentation print-out
- Export function
- Online measurement

### Test-Kit SCJN



Thanks to the **ServiceJunior-Test-Kit**, you can easily check manometers and pressure sensors, configure pressure switches and much more besides.

The Kit consists of a hand pump, with a choice of hydraulic or pneumatic, to produce a definite control pressure, and of a **ServiceJunior** as a reference device. Air, water and oil are used as pressure media.

#### Device features:

- Easy production of control pressures and adjustment of:
  - manometers
  - pressure sensors
  - pressure switches
  - safety valves
- Also suitable for portable use
- Pneumatic version from -0.95 - 60 bar and hydraulic version from 0 - 700 bar
- No additional power supply required
- Comprehensive adaptor set included

**SCMA-FCU-600 Frequency Measurement**



With the **SCMA-FCU-600** frequency signals such as turbines, flowmeters and speed sensors with a frequency output can be connected to our portable measuring instruments. Sinusoidal or squarewave signals from 1 Hz to 5 Hz can be processed with a signal amplitude of 40 mV to 10 V. Configuration through USB and PC software.

● **Power supply for external sensor**

With the **SCMA-FCU-600**, external sensors can be supplied with a voltage of 24 V.

● **Analog and CAN outlet**

The SCMA-FCU-600 can be connected to the analog or CAN input of our measuring instruments, as desired.

**SCMA-VADC-600**



Signals such as 0/4...20 mA or 0...10 V from other sensors e. g. for torque, force or displacement, can be connected to our portable measuring instruments

**Applications:**

- Force/displacement diagram
- Torque-volumetric flow rate characteristic curve

● **Current/voltage measurement**

Electric currents up to 4 ADC and voltage up to 48 VDC can be measured with this module.

**Applications:**

- Current consumption at proportional valve
- Measurement of switching states of motors/pumps



### SCP Pressure Measurement - Analog



Quick response times guarantee a quick identification of disturbing pressure peaks in the hydraulic system. The robust stainless steel construction allows a variety of applications, e. g. in hydraulics, for cooling water or in compressed air systems.

All pressure sensors are delivered with pre-assembled diagnosis adaptors (M16x2). The connection to the hydraulic system is quick and secure. Reduced assembly times.

#### Device features:

- Small size
- Robust stainless steel design
- Response time of 1 ms
- Pressure peaks logged
- Accuracy  $\pm 0.5$  %

### SCP Pressure Measurement - CAN



All the advantages of the analog SCP sensors combined with future-proof CAN bus technology. Simple wiring with the quick plug/screw connection SPEEDCON®. Plug-&-Play functionality with minimum configuration effort.

All pressure sensors are delivered with pre-assembled diagnosis adaptors (M16x2). The connection to the hydraulic system is quick and secure. Reduced assembly times.

#### Device features:

- Small size
- Robust stainless steel design
- Response time of 1 ms
- Pressure peaks logged
- Accuracy  $\pm 0.5$  %
- Quick plug/screw connection SPEEDCON®
- Sensor identification light ring
- Suitable for long cable lengths



## SCPT Pressure/Temperature Measurement - Analog



Quick response times guarantee a quick identification of disturbing pressure peaks in the hydraulic system. The robust stainless steel construction allows a variety of applications, e. g. in hydraulics, for cooling water or in compressed air systems.

All pressure sensors are delivered with pre-assembled diagnosis adaptors (M16X). The connection to the hydraulic system is quick and secure. Reduced assembly times.

### Device features:

- Robust stainless steel design
- Response time of 1 ms
- Pressure peaks logged
- Accuracy  $\pm 0.5\%$

## SCPT Pressure/Temperature Measurement - CAN



All the advantages of the analog SCPT sensors combined with future-proof CAN bus technology. Simple wiring with the quick plug/screw connection SPEEDCON®. Plug-&-Play functionality with minimum configuration effort.

All pressure sensors are delivered with pre-assembled diagnosis adaptors (M16x2). The connection to the hydraulic system is quick and secure. Reduced assembly times.

### Device features:

- Robust stainless steel design
- Response time of 1 ms
- Pressure peaks logged
- Future-proof CAN bus technology
- Simple wiring with SPEEDCON®
- Sensor identification LED
- Suitable for long cable lengths
- Accuracy  $\pm 0.5\%$

R

### SCT Temperature Measurement - Analog



Temperature measurements in hydraulics are useful for searching for faults and for avoiding damage following too high temperatures in critical components such as pumps or proportional valves.

In order to carry out a precise temperature measurement, the temperature is measured directly in the pipe or hose line.

The insertion sensors of the SCT-190 series can also be used to measure temperature in SCFT-xxx-02-02 turbine flowmeters.

#### Device features:

- High pressure-resistant temperature probe
- Temperature measurement up to 1000°C
- Flexible use
- Pressure peaks logged
- Screw-in or bulb sensor

### SCT Temperature Measurement - CAN



Temperature measurements in hydraulics are useful for searching for faults and for avoiding damage following too high temperatures in critical components such as pumps or proportional valves.

In order to carry out a precise temperature measurement, the temperature is measured directly in the tube or hose line.

The insertion sensors of the SCT-190 series can also be used to measure temperature in SCFT-xxx-02-02 turbine flowmeters.

#### Device features:

- High pressure-resistant temperature probe for measuring hydraulics
- Temperature measurement up to 150°C
- Flexible use
- Insertion sensor
- Sensor identification light ring
- Accuracy  $\pm 0.66\%$
- Quick plug/screw connection SPEEDCON®
- Suitable for long cable lengths

SPEEDCON® Registered trademark of the PHÖNIX CONTACT GmbH & Co company. KG

Catalogue 4054

Catalogue 4054

## SCRPM Speed Measurement - Analog



Performance data that depends on the rotation speed, such as the delivery rate of regulated pumps, are ideally transmitted along with the pressure and the flow rate measurement of a hydraulic drive.

Contactless speed measurement (optoelectronic principle) is fast and easy to implement.

The rotation speed is measured, e. g. at a drive shaft, and shown on the measuring instrument. No adjustment needed.

### Device features:

- Also for contactless rotation speed measurement
- Speed measurements up to 10,000 RPM
- With 3-m fixed cable

## SCFT Turbine Flowmeter - Analog



A turbine wheel is driven by the oil flow and thus set in motion. The frequencies produced are processed by a digital electronic device. The influence of disturbing flow effects is thus compensated. With the lower flow resistance  $Q_R$ , the hydraulic circulation operates at low loss.

The turbine flowmeter is equipped with an EMA-3 quick connect coupling to measure the pressure. Oil temperatures can be directly measured from the oil flow in the turbine flowmeter. Thus, all the important measured values are gathered in one location.

### Device features:

- 6 measuring ranges up to 750 l/min
- Easy assembly
- Resistant to high pressure up to 480 bar
- Low flow resistance
- Integrated pressure and temperature measurement points
- Suitable for reverse mode

### SCFTT CAN Turbine Flowmeter



A turbine wheel is driven by the oil flow and thus set in motion. The frequencies produced are processed by a digital electronic device. The influence of disturbing flow effects is thus compensated. With the lower flow resistance  $Q_R$ , the hydraulic circulation operates at low loss.

The turbine flowmeter is equipped with an EMA-3 quick connect coupling to measure the pressure.

Oil temperatures are directly measured from the oil flow in the turbine flowmeter. Thus, all the important measured values are gathered in one location.

#### Device features:

- Turbine flowmeter with integrated temperature sensor in CAN bus technology
- 6 measuring ranges up to 750 l/min
- Easy assembly
- Resistant to high pressure up to 480 bar
- Low flow resistance
- Integrated pressure and temperature measurement points
- Suitable for reverse mode
- Simple wiring with SPEEDCON®
- Suitable for long cable lengths
- Sensor identification LED

### SCLV Hydraulics Tester - Analog and CAN



Hydraulics testers test the functions of motors, pumps, valves, and hydrostatic drives. These easy-to-handle hydraulic testers can help locate faults in a hydraulic system.

Hydraulic testers can be used for a precise measurement of pressure, temperature, and flow rate when performing maintenance work on hydraulic systems and to locate the source of faults in regulated directional control valves and in the placement of valves.

The pressure loading valve with integrated bursting discs allows pressure to build up progressively to test the flow rate over the whole work area.

#### Device features:

- 2 measuring ranges up to 750 l/min
- Resistant to high pressure up to 480 bar
- Integrated overload protection
- Reverse mode (flow direction A-B)
- Also with a CAN bus connection
- CAN version with integrated temperature sensor
- Connections for pressure and temperature sensors possible

## SCQ Flowmeter - Analog



In high pressure hydraulics, a rapid identification of the rate of flow is very important. Thanks to the quick response time of the flowmeter, the dynamic behavior of hydraulic systems can be measured.

The direction indicator is helpful when searching for faults in the hydraulic system.

Quick load changes that cause damage, for example, to valves or pumps, can be identified. Assembly with the connector block allows the combined measurement of p, T, and Q. The IN-LINE adaptor for pipe or hose assembly ensures the quick integration of the flowmeter into the hydraulic system. The robust construction also permits application in extreme conditions, such as a high load change or speeds of pressure increase.

### Device features:

- Spring/piston system
- Flowmeter with direction indicator
- Response time  $\leq 2$  ms
- Compact construction
- Pressure-resistant up to 420 bar
- Wide range of viscosity
- p, T, and Q measurements possible with connector block

## SCVF Volume Counter



The **SCVF** is a volume counter for highly accurate flow measurements in hydraulic installations. A very precisely worked gear pair is driven by the fluid flow.

The **SCVF** works in a wide range of viscosity. Different thicknesses allow a variety of applications.

Thanks to the wide range of viscosity, all pumpable fluids with a certain degree of lubricity can be measured:

- mineral oils
- hydraulic oils
- grease
- brake fluid (EPDM sealing)
- Skydrol (special version)

If you need to gather exact flow measurements from a wide range of viscosity, the **SCVF** volume counter is the ideal solution.

### Device features:

- Measurement principle: volume/gear counter
- 4 measuring ranges up to 300 l/min
- Measurement accuracy  $\pm 0.5$  % FS
- Pressure-resistant up to 400 bar
- Wide range of viscosity
- Quiet
- Exact flow measurement over a wide range of viscosity
- Flexible use of different media

## SCPSDi Pressure Switch



The **SCPSDi** is an electronic pressure switch with:

- Pressure display
- 2 programmable switching outputs
- Optional analog output signal
- IO-link interface
- VDMA menu navigation

The new construction concept and the resulting assembly possibilities combined with multiple connection options are the most important characteristics of the **SCPSDi**.

This unique scope of functions makes the **SCPSDi** ideal for long-term series use in industrial applications.

### Device features:

- IO-Link
- VDMA menu
- ECO Mode
- Rotating >360°
- 180° reversible display
- Analog output V/mA
- Reliable operation thanks to LOCK
- Compact
- Robust
- MPa, bar, PSI
- Metal housing
- Mounting width 35 mm
- Mounting height 78 mm

## Controller Family



Controllers are used in control, management, and monitoring systems in which switch or analog signals or a display is/are necessary.

The controllers can replace:

- mechanical switches
- mechanical displays (manometers, thermometers, gauge-glasses)
- sensors

and combine all the functions of the above-named components in a single device.

### Device features:

- Large display
- Freely adjustable
- Robust metal design
- Compact
- Long term stability
- Reliable
- Resistant to interference

## SCPSD PressureController



The PressureController combines the functions of a pressure switch, a pressure sensor, and a display unit:

- Pressure display (manometer)
- Switching outputs
- Analog signal

Simple operation, compact construction and high reliability are the most important characteristics of the PressureController. The PressureController offers exceptional technical data and optimum pressure management, combined with various assembly options. It is therefore ideal for long-term series use in industrial applications.

Each switching output can be configured individually:

- Normally open/normally closed contact
- On/off switching pressures
- Delay times
- Hysteresis/window function
- Attenuation

These comfortable switch functions enable intelligent configurations which are not possible with mechanical switches. Thus, several switches can be replaced by a single controller.

### Device features:

- Compact
- Robust
- Reliable
- Easy operation
- Long term stability
- Excellent interference resistance
- Metal housing
- High protection class
- Many versions
- Rotating
- Analog output
- Password
- MPa, bar, PSI



Catalogue 4083

## SCTSD TemperatureController



The TemperatureController combines the functions of a temperature switch, a temperature sensor, and a display unit:

- Temperature display (thermometer)
- Switching outputs
- Analog signal

Simple operation, varied functionality, and a modular design are the most important characteristics of the TemperatureController. The TemperatureController offers exceptional technical data and optimum temperature management, combined with various assembly options. It is therefore ideal when the temperature must be safely monitored and clearly displayed.

Each switching output can be configured individually:

- Normally open/normally closed contact
- On/off switching pressures
- Delay times
- Hysteresis/window function
- Time delay

These comfortable switch functions enable intelligent configurations which are not possible with mechanical switches. Thus, several switches can be replaced by a single controller.

### Device features:

- Compact
- Robust
- Reliable
- Metal housing
- Modular design
- Many versions
- Analog output
- Rotating
- Password
- °C, °F



Catalogue 4083



## SCTSD-L Combination Switch



The **SCTSD-L** combination switch was devised around the requirements of hydraulic unit constructions and combines the functions of a fixed mechanical level switch with those of a configurable electronic temperature switch with a display.

### Level

The tank level is measured by a highly dynamic and fully encapsulated magnetic float and switches the bistable dry reed contacts. The M12 pin assignment is compatible with conventional systems. The level contacts are firmly preset according to normal tank sizes. Two standard switching output versions are available.

### Temperature

The temperature is measured via the temperature sensor and assessed by the SCTSD TemperatureController and continually displayed. These comfortable switch functions (e. g. window function) enable intelligent configurations which are not possible with mechanical temperature switches.

### Device features:

- Compact construction
- Temperature display
- Individually configurable temperature switch outputs
- Small switching hysteresis
- Preset
  - for standard oils
  - for cooling
  - for shutdown ( $T_{max}$ )
- Fixed level contacts
- Bistable contacts
- Preset level
  - Warning and shutdown min
  - Shutdown min/max
- Up to 1 m bar length



Catalogue 4083

## SCLTSD LevelTempController



The LevelTempController enables the temperature and the level to be configured and displayed separately on the same platform. When monitoring the tank, this integration of level and temperature functionality opens up many possibilities.

The LevelTempController combines the functions of a level/temperature switch, a level/temperature sensor, and a level/temperature display:

- Level/temperature display
- Switching outputs
- Analog signal

### Level

The position of the float is finely graduated ( $\geq 5$  mm) and continually logged and shown in mm or inches in the display. The continual logging of the level means that there is no risk of individual mechanical contacts 'sticking'. This greatly increases the operational safety of the monitored installation.

### Temperature

The temperature in the medium is continually logged and shown on the display. As with the LevelController, all switching outputs can be configured individually. In addition, all the comfortable switching functions are available, including the window and hysteresis functions, normally open and normally closed contacts, and an analog output for temperature.

### Device features:

- Proven measurement system
- Rotating
- Level display
- mm/inch/% display
- High & low display
- Analog output
- Switching outputs
- One borehole only
- No surge pipe necessary
- Replaces several mechanical switches



Catalogue 4083



## SCLSD LevelController



The LevelController combines the functions of a level switch, a level sensor, and a level display:

- Level display (gauge-glass)
- Switching outputs
- Analog signal

The LevelController is best suited for monitoring tank levels.

A variety of applications can be comfortably implemented or subsequently corrected through the menu-driven configuration of the level switching points. As the switching points no longer need to be given when ordering, the usual variability found in mechanical level switches is reduced.

Each switching output can be configured individually:

- Normally open/normally closed contact
- Higher/lower level switching point
- Delay times
- Hysteresis/window function
- Attenuation

These comfortable switch functions enable intelligent configurations which are not possible with mechanical switches. Thus, several switches can be replaced by a single controller.

### Device features:

- Proven measurement system
- Level display
- mm/inch/% display
- High & low display
- Analog output
- Switching outputs
- No surge pipe necessary
- Replaces several mechanical switches
- Rotating



Catalogue 4083

## SCOTC OilTankController



In addition to the LevelTempController, the OilTankController offers standardized connections for an air filter and a filling coupling.

When monitoring the tank for series use, this integration of level and temperature functionality together with air filter and fill adapter port opens up many possibilities. Only one connecting bore is needed for four functions.

The OilTankController combines the functions of a level/temperature switch, a level/temperature sensor, and a level/temperature display:

- Level/temperature display (Thermometer/gauge-glass)
- Switching outputs
- Analog signal

Each switching output can be configured individually:

A variety of applications can be comfortably implemented or subsequently corrected through the menu-driven configuration of the level switching points. As the switching points no longer need to be given when ordering, the usual variability found in mechanical level switches is reduced.

### Device features:

- Proven measurement system
- Level/temperature display
- mm/inch/% display
- High & low display
- One borehole only
- Continual level measurement
- Connection
  - Filling coupling
  - Air filter
  - Negative pressure
- No surge pipe necessary



Catalogue 4083



## SCP01 Pressure Sensors



The **SCP01** pressure sensor was designed for the requirements of industrial applications and is used for control, management, or monitoring systems. The **SCP01** is characterized by its compact form, high linearity, and excellent interference resistance. Thanks to its speed of response, the **SCP01** is also used for rapid control processes. The compact stainless steel housing is designed for harsh ambient conditions. All parts in contact with the medium are manufactured from stainless steel and, in combination with welded thin-layer measuring cell, ensure high medium compatibility. All electronic parts are encapsulated as protection against vibrations and humidity.

An EDM hole is integrated in order to ensure an exact pressure measurement free from interference. It minimizes air cavitation and thus protects the measuring cell from any pressure blows or pressure peaks that may occur.

Thanks to its long life, high accuracy, high reliability, and robust stainless steel construction, it is the device best suited for sustained series use in hydraulic applications.

### Device features:

- Small construction
- Stainless steel measuring cell
- Stainless steel housing
- Resistant to shock and vibrations
- Wide-ranging media compatibility
- High linearity
- Long term stability
- Medium temperature -40 ... 125 °C
- Up to 1000 bar
- High burst pressure
- 1 ms
- EDM-drilling
- Encapsulated electronic parts

Catalogue 4083

## Pressure sensors SCP02



The **SCP02** was specially designed for use in mobile work machines. For this, the **SCP02** has received e1 approval and is manufactured with the latest manufacturing methods, in accordance with ISO/TS 16949.

Its resistance to shock and vibrations, EMC properties, power supply, and wider temperature range have been designed for this area of application.

Thanks to its speed of response, the **SCP02** can also be used for rapid control processes.

The compact stainless steel housing and the plastic plug enable use in harsh ambient conditions, such as are found in mobile hydraulics.

All parts in contact with the medium are manufactured from stainless steel (1.4548) and, in combination with the welded thin-layer measuring cell, ensure high medium compatibility.

An EDM hole is integrated in order to ensure an exact pressure measurement free from interference. It minimizes air cavitation and thus protects the measuring cell from any pressure blows or pressure peaks that may occur.

### Device features:

- Small construction
- Stainless steel measuring cell
- Stainless steel housing
- Resistant to shock and vibrations
- High degree of protection
- E1 road approval
- Medium temperature -40 ... 150 °C
- Up to 1000 bar
- 1 ms
- Up to 36 V wiring systems



Catalogue 4083

## SCPS01 Pressure Switch



The **SCPS01** electronic pressure switch was conceived for use in series machines.

In order to make assembly more straightforward, the pressure switches can be pre-programmed to client-specific values upon request. Time-consuming adjustments or configuration under pressure are therefore unnecessary. The system manufacturer can configure the pressure switches by software. This excludes the possibility of an unauthorized end user manipulating the switch.

The pressure switches do not contain any mechanical moving parts. All parts in contact with the medium are made out of stainless steel and, in combination with the welded thin-layer measuring cell, ensure high medium compatibility. A cushioning mechanism can be optionally integrated in the medium inlet. The stainless steel housing enables use in extremely harsh ambient conditions.

In order to ensure a wide field of use, the EMC properties and shock and vibration resistance are configured for use in mobile work machines. The e-1 approval even permits the **SCPS01** to be installed in vehicles used on public roads.

Thanks to their robust and compact construction, combined with their long-term stability and attractive price, the **SCPS01** are the alternative to mechanical pressure switches.

### Device features:

- Long life
- No re-adjustment
- Engineered for harsh environments
- Precise switching



Catalogue 4083

## SCP-EX Pressure Sensors



The **SCP-EX** can be configured for Zone 1 and conforms with Directive 94/9/EC. Thanks to the appropriate protective circuits, polarity reversal protection, overvoltage protection, and power dissipation limitation will be activated in the case of a fault. Its wide-reaching industrial application options are guaranteed through high accuracy and a robust and compact construction. Various pressure transducers are available thanks to its compatibility with different mechanical and electrical connections.

For Zone 1, in which explosive atmospheres, such as a mix of inflammable compounds in the form of gas, steam, or haze and air, sometimes occur in normal operation. It is essential to adhere to the relevant national safety regulations when assembling, commissioning, and operating these pressure transducers.

### Device features:

- Measuring ranges 0 ... 1000 bar
- ATEX approval for Zone 1
  - II 2G Ex ia IIC T4
- Output signal 4 ... 20 mA
- High reliability

R

Catalogue 4083

## SCT-150 Temperature Sensors



A compact construction and high pressure resistance characterize the **SCT-150** electronic temperature sensor.

If the temperature needs to be measured under high pressure and a compact construction is necessary, the **SCT** can be used.

Thanks to its pressure resistance up to 630 bar, the **SCT** temperature sensor is suited to the needs of hydraulic applications.

It performs precise and quick temperature measurements.

The temperature sensors in the **SCT** series are compatible with the **SCE** panel measuring instruments. This allows the medium temperature as well as the hydraulic pressure to be measured, controlled, and evaluated.

### Device features:

- Pressure-resistant up to 630 bar
- Compact construction
- Robust steel housing
- Easy assembly
- -25 °C ... +100 °C

## SCE-020 Digital Display Unit



Multiple connections, a flexible display and numerous outlets characterize the **SCE** digital display unit. The **SCE-020** converts analog standard signals (in 0 ... 10 V to 0/4 ... 20 mA ranges) into easily understood measurement values/units.

Thus, the **SCE-020** can easily display any sensor (pressure, temperature, torque, length etc.) desired.

The display can be read from a great distance. In order to present different measuring values, the desired measurement range and the decimal point can be set easily and in a user-friendly way. Additional units are shown on a separate illuminated surface. The power supply can range from 11 to 30 VDC. An adjustable limit value can be monitored through the potential-free switching output. The analog output and the RS232 series interface can forward the signal to a corresponding peripheral device. If different measuring values need to be presented easily and in a flexible manner, the **SCE-020** display unit can be used.

### Device features:

- Easily readable digital display:
  - large
  - bright
- Programmable
- Free choice of unit
- Input:
  - current 0/4 ... 20 mA
  - voltage 0 ... 10 V
  - frequency 0 ... 8 kHz
- Switching output
- Loophrough function:
  - analog output
  - series interface
- Standard housing 96 x 48 mm

Catalogue 4083

Catalogue 4083

## SCK Cable



**SensoControl®** cables are designed according to the requirements of industrial sensors and switches.

M12 cables and M12 plugs are therefore usually

- compact
- screened
- 5-pin

### 5-pin design

The 5-pin cables are suitable for both 4 and 5-pin connections. 5-pin cables are fully compatible with sensor versions with 4-pin plugs.

This means that a (5-pin) cable design can always be used for pressure switches (Controller Family SCxSD & SCOTC) and sensors irrespective of the plug version and the different number of pins.

The SCK-400-xxx-x5 cables are compatible with all components with M12 plug connections.

### Shielding

The screening ensures high interference resistance and operational safety.

- High EMC protection

### Device features:

- One cable for everything
- Compact
- Resistant to interference
- Compatible with:
  - sensors
  - controllers
- M12 plugs
- DIN EN 175301 (connector plugs)
- Different lengths

Catalogue 4083