

Ball Valves

2-Way Series

Pressures to 20,000 psi (1379 bar)

Parker Autoclave Engineers high-pressure ball valves have been designed to provide superior quality for maximum performance within a variety of valve styles, sizes, and process connections. Some of the more unique design innovations include an integral one-piece trunnion mounted style ball and stem that eliminates the shear failure common in two piece designs, re-torqueable seat glands that result in longer seat life, and a low friction stem seal that reduces actuation torque and enhances cycle life.

These ball valves can also be modified to incorporate the use of special materials, seals for high temperature applications, subsea models, and valve actuators.

When it comes to high-pressure applications, these ball valves with the associated high-pressure components, provide the critical performance demanded by the high pressure market.

Ball Valve Features:

- One-piece, trunnion mounted style, stem design eliminates shear failure and reduces the effects of side loading found in two piece designs.
- Re-torqueable seat glands for longer seat life.
- PEEK seats offer excellent resistance to chemicals, heat, and wear/abrasion.
- Full-port flow path minimizes pressure drop.
- 316 cold worked stainless steel construction.
- Low friction pressure assisted graphite filled PTFE stem seal increases cycle life and reduces operating torque.
- Quarter turn from open to close with positive stop.
- Viton o-rings for operation from 0°F (-17.8°C) to 400°F (204°C).
- Optional o-rings available for high-temperature applications.
- Optional wetted materials.
- Wide selection of tube and pipe end fittings available.
- Electric and pneumatic actuator options.



Flow Configuration

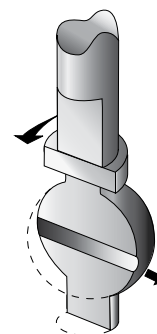

Two-Way
Shut-Off

Applications:

- Laboratories
- Test Stands
- Control Panels
- Chemical Research
- Pilot Plants
- Water Blast Pumping Units
- High volume chemical injection skids.



Autoclave
Engineers 
www.autoclave.com

Ball Valves - 2-Way Series (1/4" Orifice)

Pressures to 20,000 psi (1379 bar) .250" (6.35mm) Orifice

Connection	MAWP @ Room Temperature	Minimum Orifice inches(mm)
W125	15,000 psi (1034 bar)	.094 (2.39)
SW250	15,000 psi (1034 bar)	.128 (3.25)
SW375	15,000 psi (1034 bar)	.250 (6.35)
SW500	10,000 psi (690 bar)	.250 (6.35)
SF250CX20	20,000 psi (1379 bar)	.109 (2.77)
SF375CX20	20,000 psi (1379 bar)	.203 (5.16)
SF562CX20	20,000 psi (1379 bar)	.250 (6.35)
F250C	20,000 psi (1379 bar)	.094 (2.39)
F375C	20,000 psi (1379 bar)	.125 (3.17)
F562C	20,000 psi (1379 bar)	.188 (4.77)
1/8" NPT	15,000 psi (1034 bar)	.250 (6.35)
1/4" NPT	15,000 psi (1034 bar)	.250 (6.35)
3/8" NPT	15,000 psi (1034 bar)	.250 (6.35)
1/2" NPT	15,000 psi (1034 bar)	.250 (6.35)

Valve C_v=1.51

MAWP: Maximum Allowable Working Pressure
C_v listed is for maximum orifice size of .250 inches only.
Consult factory for C_v of valves with reduced orifice sizes.

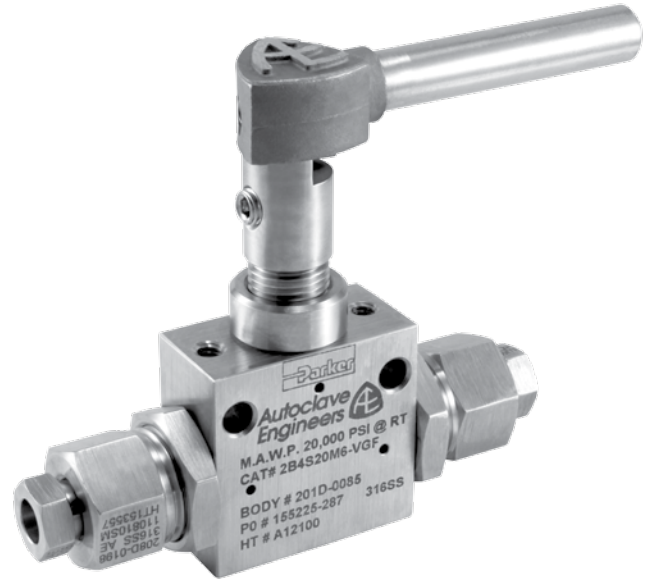

PRESSURE TEMPERATURE RATINGS

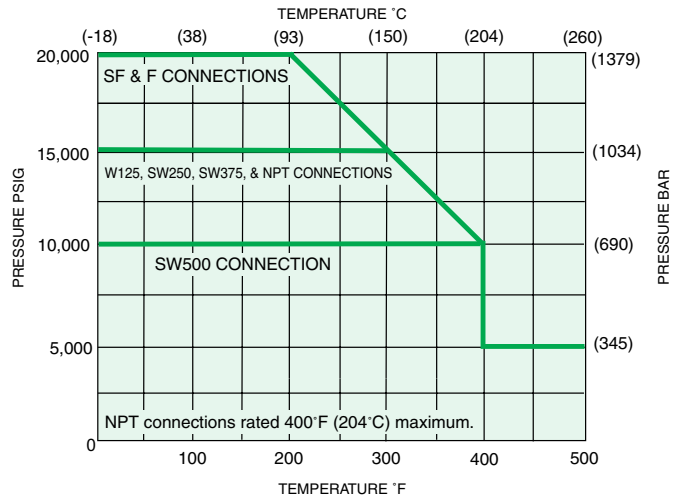

Pressure ratings are determined by the end connections chosen, see chart.

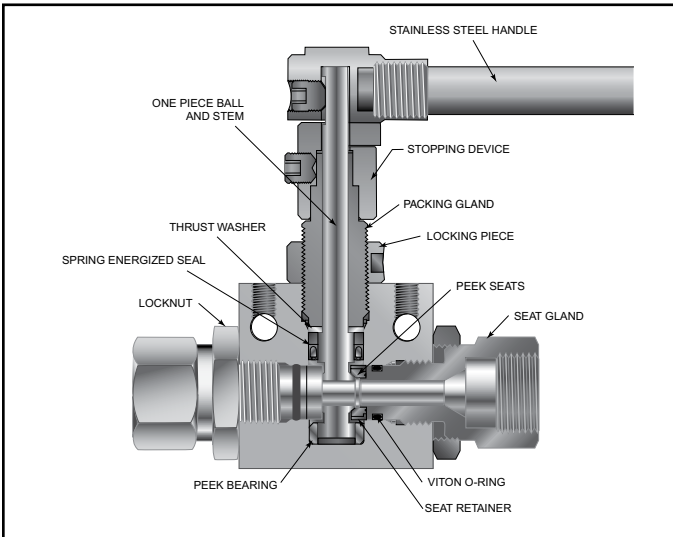

NOTE: Ball valves are not recommended for critical gas applications such as Hydrogen, Helium or other small molecular gases.

Ordering Procedure

For complete information on available end connections and material options, see next page. 2-way ball valves are furnished complete with tube or pipe connections.

Typical catalog number: **2B 4 S 20 M9**

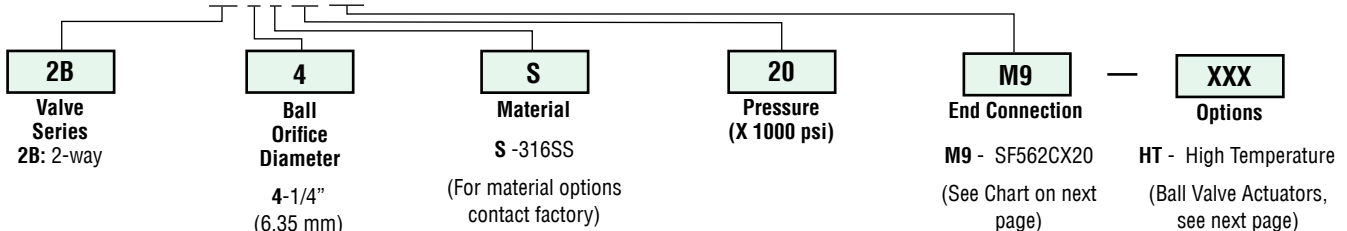

All general terms and conditions of sale, including limitations of our liability, apply to all products and services sold.

End Connection Options

Catalog Number	End Connection Number	Connection	MAWP @ Room Temperature	Seat Gland Hex Inches(mm)
2B4S15L2	L2	W125	15,000 psi (1034 bar)	1 (25.40)
2B4S15L4	L4	SW250	15,000 psi (1034 bar)	1 (25.40)
2B4S15L6	L6	SW375	15,000 psi (1034 bar)	1 (25.40)
2B4S10L8	L8	SW500	10,000 psi (690 bar)	1 (25.40)
2B4S20M4	M4	SF250CX20	20,000 psi (1379 bar)	1 (25.40)
2B4S20M6	M6	SF375CX20	20,000 psi (1379 bar)	1 (25.40)
2B4S20M9	M9	SF562CX20	20,000 psi (1379 bar)	1 (25.40)
2B4S20H4	H4	F250C	20,000 psi (1379 bar)	1 (25.40)
2B4S20H6	H6	F375C	20,000 psi (1379 bar)	1 (25.40)
2B4S20H9	H9	F562C	20,000 psi (1379 bar)	1.38 (35.05)
2B4S15P2	P2	1/8" NPT	15,000 psi (1034 bar)	1 (25.40)
2B4S15P4	P4	1/4" NPT	15,000 psi (1034 bar)	1 (25.40)
2B4S15P6	P6	3/8" NPT	15,000 psi (1034 bar)	1 (25.40)
2B4S15P8	P8	1/2" NPT	15,000 psi (1034 bar)	1.38 (35.05)

MAWP: Maximum Allowable Working Pressure

See ball valve option/details section for end connection details, material, and high temperature options.

Ball Valve Options

Pneumatic Actuator

- AO - Air-to-open/spring to close
- AC - Air-to-close/spring to open
- AOC - Air-to-open-and-close (double action)

Electric Actuator

- EO1 - 120 volt AC 50/60 Hz
- EO2 - 220 volt AC 50/60 Hz
- EO3 - 24 VDC

Actuator Operating Temperature:

- Pneumatic: 0°F to 175°F (-17°C to 79°C)
- Electric: 0°F to 160°F (-17°C to 71°C)

High Temperature Option:

- HT - for media temperature up to 500°F (260°C)

See ball valve actuator section for full description, additional information, and options.

Valve Maintenance

Repair Kits: add "R" to the front of valve catalog first 4 numbers for proper repair kit.
(Example: **R2B4S**)

Consult your Parker Autoclave Engineers representative for pricing on repair kits. Refer to the Operation and Maintenance manual for proper maintenance procedures.

Ball Valves - 2-Way Series (3/8" Orifice)

Pressures to 20,000 psi (1379 bar) .375" (9.52mm) Orifice

Connection	MAWP @ Room Temperature	Minimum Orifice inches(mm)
SW500	10,000 psi (690 bar)	.375 (9.52)
SF375CX20	20,000 psi (1379 bar)	.203 (5.16)
SF562CX20	20,000 psi (1379 bar)	.312 (7.92)
SF750CX20	20,000 psi (1379 bar)	.328 (8.33)
1/4" NPT	15,000 psi (1034 bar)	.375 (9.52)
3/8" NPT	15,000 psi (1034 bar)	.375 (9.52)
1/2" NPT	15,000 psi (1034 bar)	.375 (9.52)

Valve C_v=3.51

MAWP: Maximum Allowable Working Pressure
C_v listed is for maximum orifice size of .375 inches only.
Consult factory for C_v of valves with reduced orifice sizes.

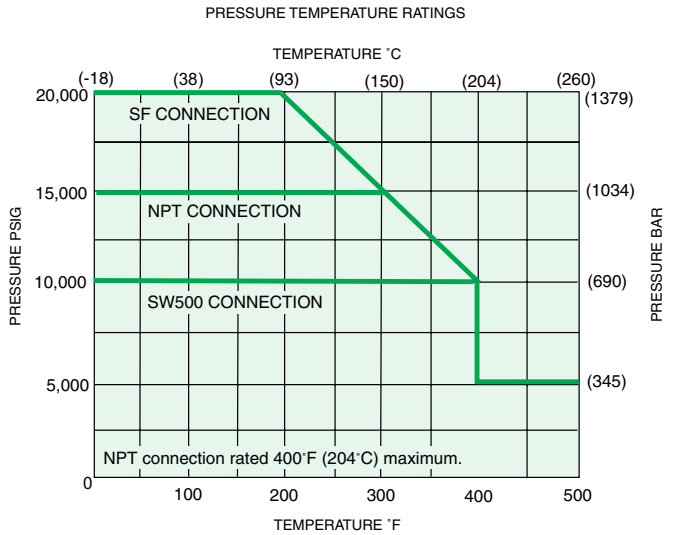
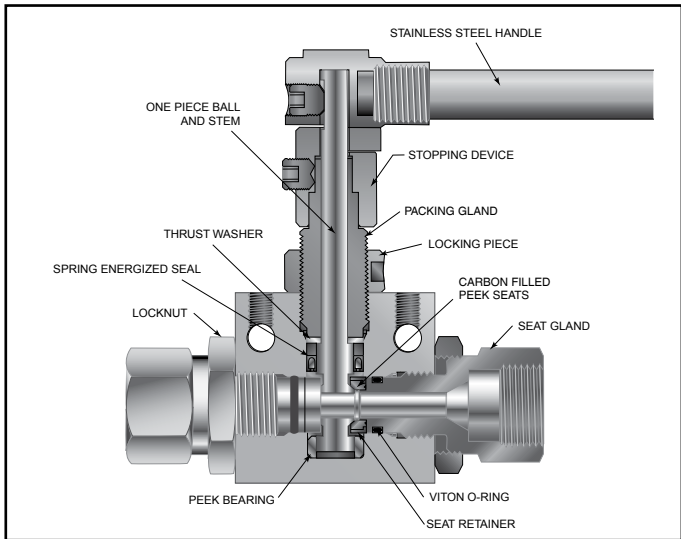
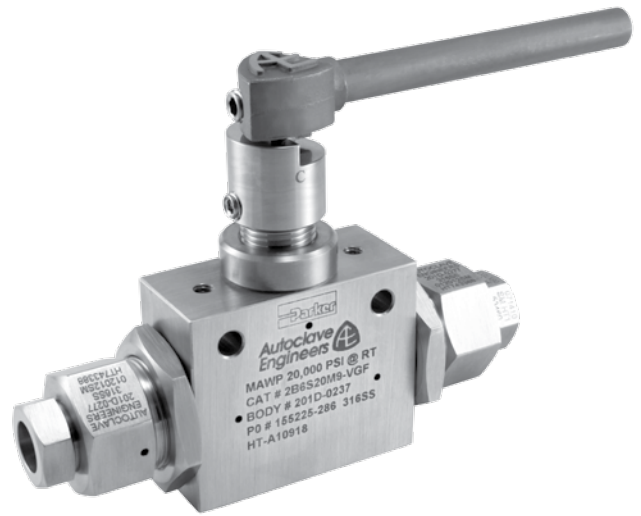

Pressure ratings are determined by the end connections chosen, see chart.

NOTE: Ball valves are not recommended for critical gas applications such as Hydrogen, Helium or other small molecular gases.

Ordering Procedure

For complete information on available end connections and material options, see next page. 2-way ball valves are furnished complete with tube or pipe connections.

Typical catalog number: **2B 6 S 20 M9**

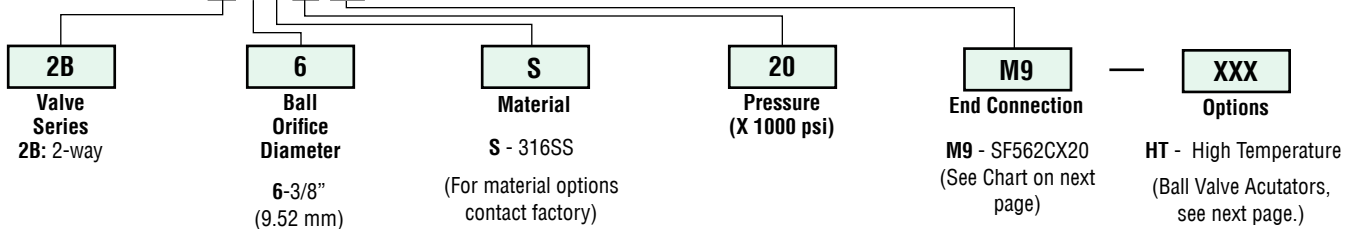

End Connection Options

Catalog Number	End Connection Number	Connection	MAWP @ Room Temperature	Seat Gland Hex Inches(mm)
2B6S10L8	L8	SW500	10,000 psi (690 bar)	1.38 (35.05)
2B6S20M6	M6	SF375CX20	20,000 psi (1379 bar)	1.38 (35.05)
2B6S20M9	M9	SF562CX20	20,000 psi (1379 bar)	1.38 (35.05)
2B6S20M12	M12	SF750CX20	20,000 psi (1379 bar)	1.38 (35.05)
2B6S15P4	P4	1/4" NPT	15,000 psi (1034 bar)	1.38 (35.05)
2B6S15P6	P6	3/8" NPT	15,000 psi (1034 bar)	1.38 (35.05)
2B6S15P8	P8	1/2" NPT	15,000 psi (1034 bar)	1.38 (35.05)

MAWP: Maximum Allowable Working Pressure

See ball valve option/details section for end connection details, material, and high temperature options.

Ball Valve Options

Pneumatic Actuator

- AO - Air-to-open/spring to close
- AC - Air-to-close/spring to open
- AOC - Air-to-open-and-close (double action)

Electric Actuator

- EO1 - 120 volt AC 50/60 Hz
- EO2 - 220 volt AC 50/60 Hz
- EO3 - 24 VDC

Actuator Operating Temperature:

- Pneumatic: 0°F to 175°F (-17°C to 79°C)
- Electric: 0°F to 160°F (-17°C to 71°C)

High Temperature Option:

- HT - for media temperature up to 500°F (260°C)

See ball valve actuator section for full description, additional information, and options.

Valve Maintenance

Repair Kits: add "R" to the front of valve catalog first 4 numbers for proper repair kit.
(Example: **R2B6S**)

Consult your Parker Autoclave Engineers representative for pricing on repair kits. Refer to the Operation and Maintenance manual for proper maintenance procedures.

Ball Valves - 2-Way Series (1/2" Orifice)

Pressures to 15,000 psi (1034 bar) .500" (12.7mm) Orifice

Connection	MAWP @ Room Temperature	Minimum Orifice Inches (mm)
SF750CX20	15,000 psi (1034 bar)	.500 (12.70)
SF1000CX20	15,000 psi (1034 bar)	.500 (12.70)
3/4" NPT	10,000 psi (690 bar)	.500 (12.70)
1" NPT	10,000 psi (690 bar)	.500 (12.70)

Valve C_v=10.20

MAWP: Maximum Allowable Working Pressure

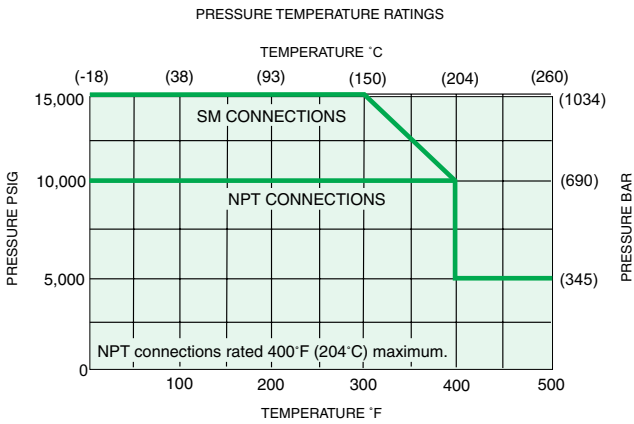
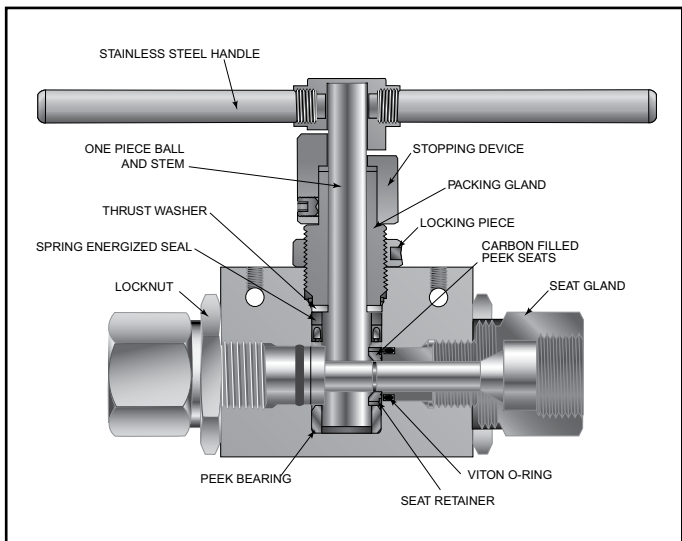
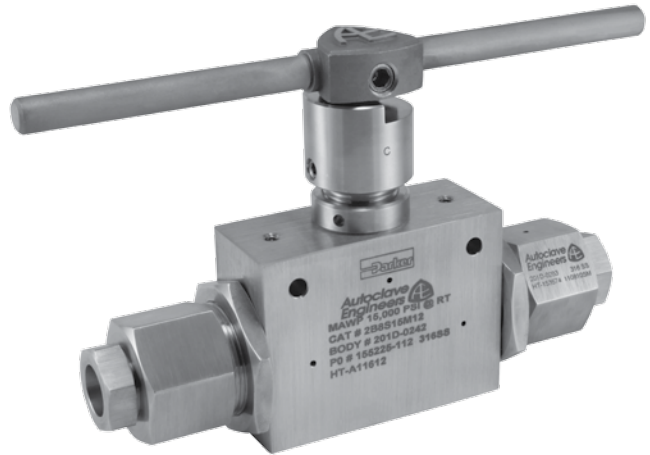

Pressure ratings are determined by the end connections chosen, see chart.

NOTE: Ball valves are not recommended for critical gas applications such as Hydrogen, Helium or other small molecular gases.

Ordering Procedure

For complete information on available end connections and material options, see next page. 2-way ball valves are furnished complete with tube or pipe connections.

Typical catalog number: **2B 8 S 15 M12**

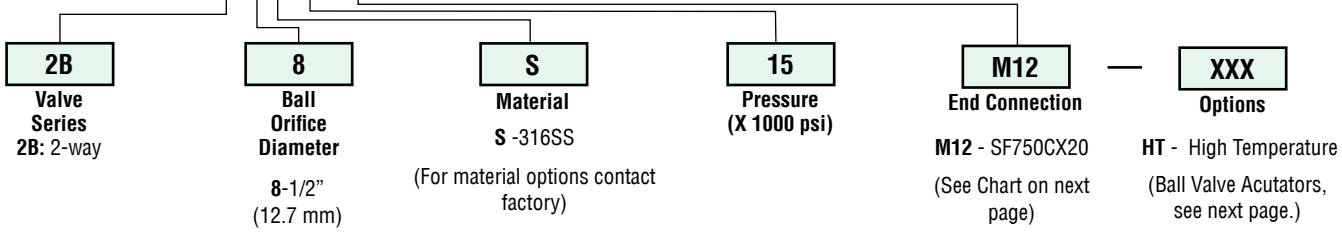

End Connection Options

Catalog Number	End Connection Number	Connection	MAWP @ Room Temperature	Seat Gland Hex Inches(mm)
2B8S15M12	M12	SF750CX20	15,000 psi (1034 bar)	1.75 (44.5)
2B8S15M16	M16	SF1000CX20	15,000 psi (1034 bar)	1.75 (44.5)
2B8S10P12	P12	3/4" NPT	10,000 psi (690 bar)	1.75 (44.5)
2B8S10P16	P16	1" NPT	10,000 psi (690 bar)	1.75 (44.5)

MAWP: Maximum Allowable Working Pressure

See ball valve option/details section for end connection details, material, and high temperature options.

Ball Valve Options

Pneumatic Actuator

- AO - Air-to-open/spring to close
- AC - Air-to-close/spring to open
- AOC - Air-to-open-and-close (double action)

Electric Actuator

- EO1 - 120 volt AC 50/60 Hz
- EO2 - 220 volt AC 50/60 Hz
- EO3 - 24 VDC

Actuator Operating Temperature:

- Pneumatic: 0°F to 175°F (-17°C to 79°C)
- Electric: 0°F to 160°F (-17°C to 71°C)

High Temperature Option:

- HT - for media temperature up to 500°F (260°C)

See ball valve Actuator section for full description, additional information, and options.

Valve Maintenance

Repair Kits: add "R" to the front of valve catalog first 4 numbers for proper repair kit.
(Example: **R2B8S**)

Consult your Parker Autoclave Engineers representative for pricing on repair kits. Refer to the Operation and Maintenance manual for proper maintenance procedures.

Ball Valve Dimensions - inches (mm)

	VALVE MODELS		
	2B4S	2B6S	2B8S
A	4.33 (109.99)	4.97 (126.30)	5.97 (151.64)
B	4.19 (106.49)	5.53 (140.41)	7.73 (196.46)
C	2.00 (50.80)	3.00 (76.20)	4.13 (104.78)
D	3.37 (85.55)	4.99 (126.82)	5.12 (130.04)
E	3.90 (99.02)	5.52 (140.32)	*10.25 (260.35)
F	1.13 (28.58)	1.38 (34.92)	1.76 (44.70)
G	1.50 (38.10)	2.00 (50.80)	3.00 (76.20)
H	0.75 (19.05)	1.00 (25.40)	1.50 (38.10)
J	0.43 (10.92)	0.41 (10.31)	0.50 (12.70)
K	0.28 (7.11)	0.28 (7.11)	0.28 (7.11)
L	1.91 (48.41)	2.50 (63.50)	3.09 (78.58)
Block Thickness	1.00 (25.40)	1.38 (34.92)	1.75 (44.45)

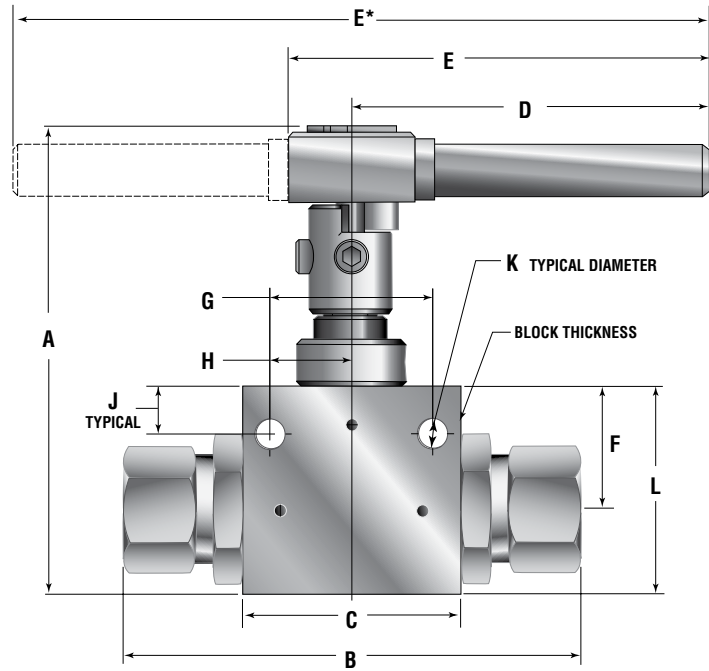

Ball Valve Panel Mounting Dimensions - inches (mm)

	VALVE MODELS		
	2B4S	2B6S	2B8S
A	1.500 (38.10)	2.000 (50.80)	3.000 (76.20)
B	0.750 (19.05)	1.000 (25.40)	1.500 (38.10)
C	1.06 (26.92)	1.50 (38.10)	1.88 (47.63)
D	0.28 (7.11)	0.28 (7.11)	0.28 (7.11)

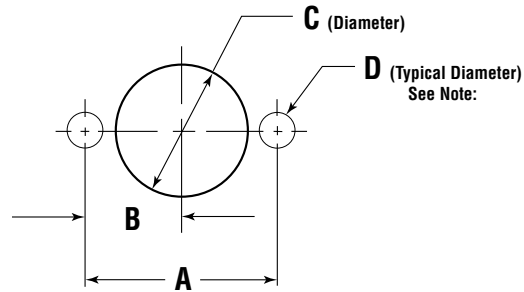

All dimensions are for reference only and are subject to change without notice.

Note: Body mounting 1/4" - 20 thread

Ball Valves - 2-Way Series (3/4" Orifice)

Pressures to 15,000 psi (1034 bar) .750" (19.05mm) Orifice

Connection	MAWP @ Room Temperature	Minimum Orifice Inches (mm)
SF1000CX10	15,000 psi (1034 bar)	.688 (17.48)
1/2" NPT	15,000 psi (1034 bar)	.688 (17.48)
3/4" NPT	10,000 psi (690 bar)	.750 (19.05)
1" NPT	10,000 psi (690 bar)	.750 (19.05)

Valve C_v=21

MAWP: Maximum Allowable Working Pressure

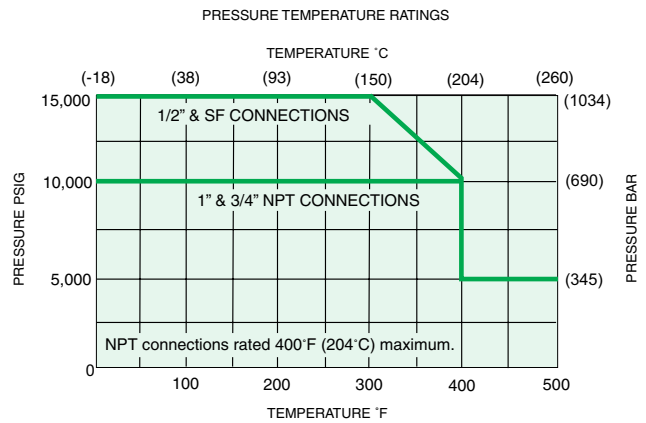
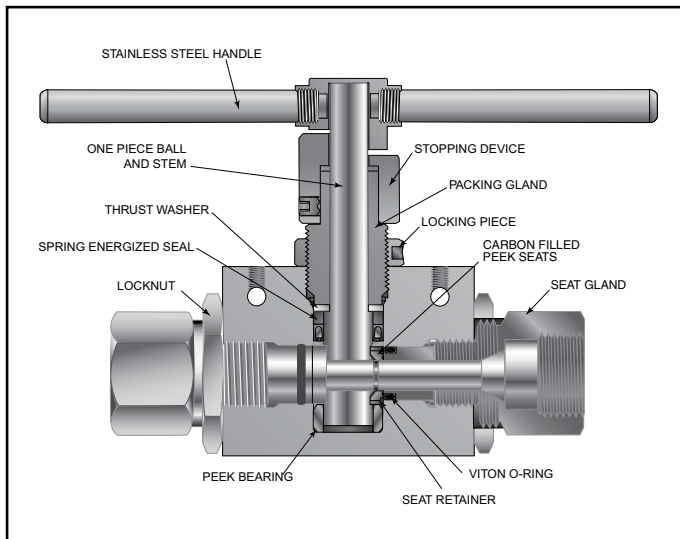
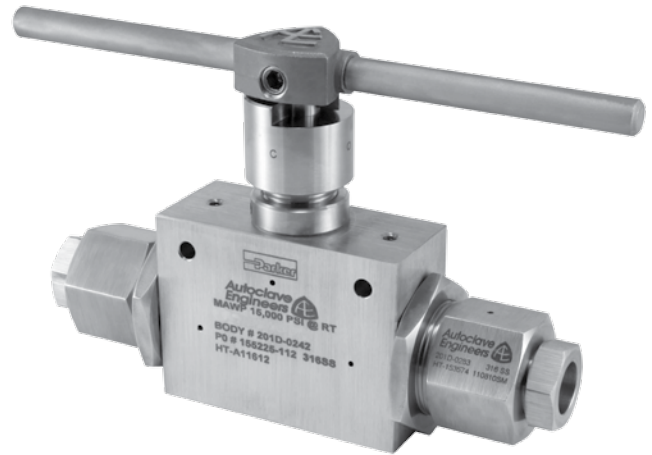

Pressure ratings are determined by the end connections chosen, see chart.

NOTE: Ball valves are not recommended for critical gas applications such as Hydrogen, Helium or other small molecular gases.

Ordering Procedure

For complete information on available end connections and material options, see next page. 2-way ball valves are furnished complete with tube or pipe connections.

Typical catalog number: **2B 12 S 15 M16**

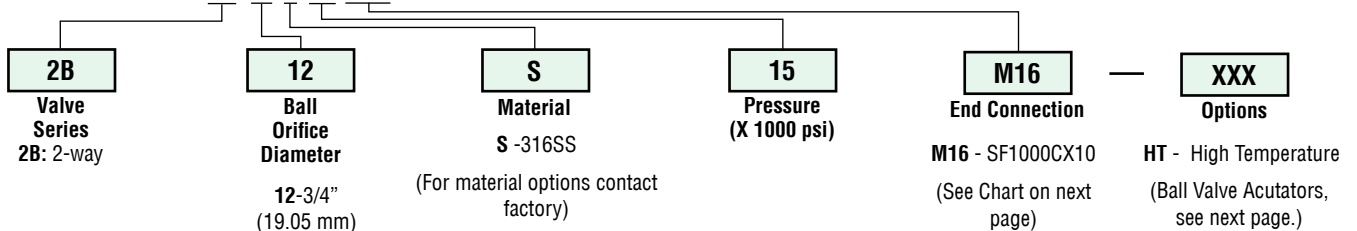

All general terms and conditions of sale, including limitations of our liability, apply to all products and services sold.

End Connection Options

Catalog Number	End Connection Number	Connection	MAWP @ Room Temperature	Seat Gland Hex Inches(mm)
2B12S15M16	M16	SF1000CX10	15,000 psi (1034 bar)	1.88 (47.6)
2B12S15P8	P8	1/2" NPT	15,000 psi (1034 bar)	1.88 (47.6)
2B12S10P12	P12	3/4" NPT	10,000 psi (690 bar)	1.88 (47.6)
2B12S10P16	P16	1" NPT	10,000 psi (690 bar)	1.88 (47.6)

MAWP: Maximum Allowable Working Pressure

See ball valve option/details section for end connection details, material, and high temperature options.

Ball Valve Options

Valve Actuators

Consult Factory

Actuator Operating Temperature:

Pneumatic: 0°F to 175°F (-17°C to 79°C)

Electric: 0°F to 160°F (-17°C to 71°C)

Valve Maintenance

Repair Kits: add "R" to the front of valve catalog first 4 numbers for proper repair kit.
(Example: **R2B12S**)

Consult your Parker Autoclave Engineers representative for pricing on repair kits. Refer to the Operation and Maintenance manual for proper maintenance procedures.

Ball Valve Dimensions - inches (mm)

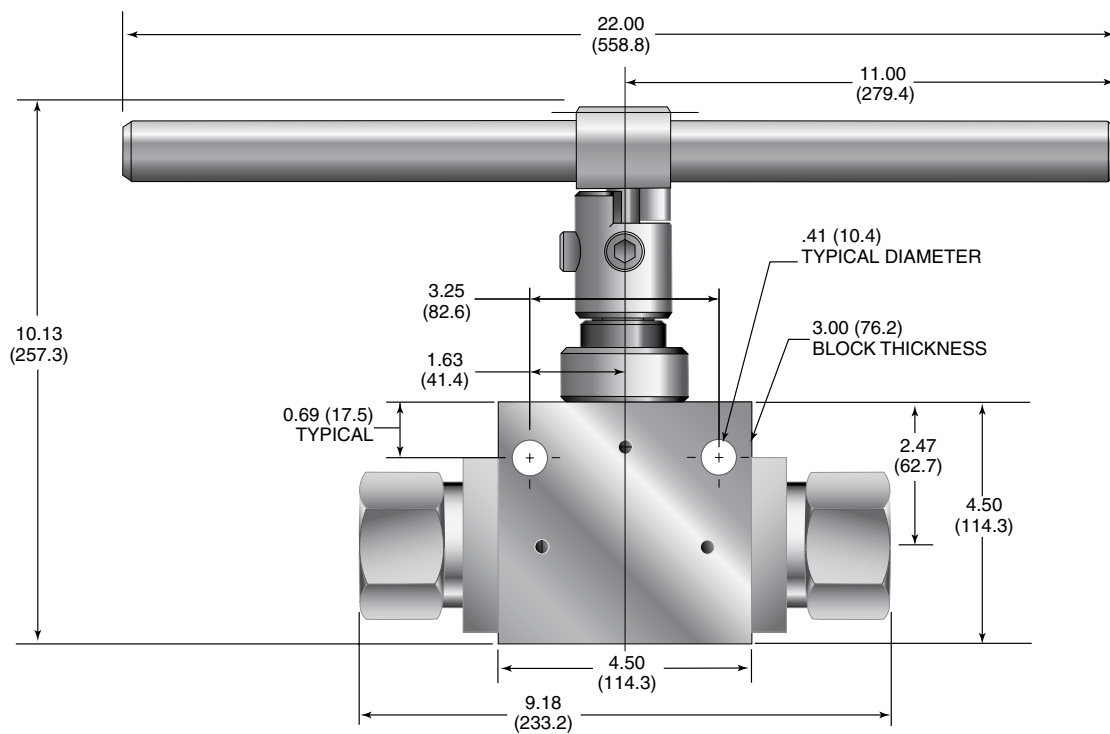

Ball Valve Panel Mounting Dimensions - inches (mm)

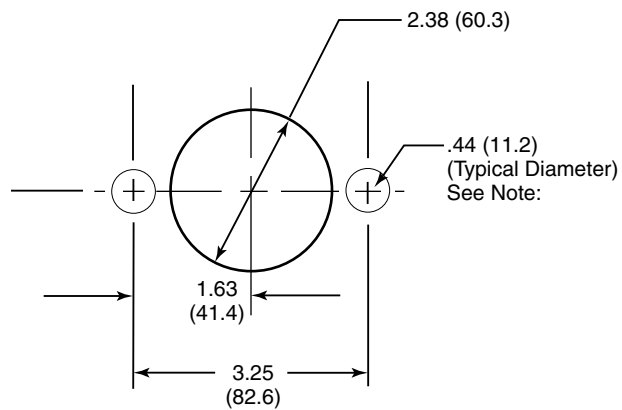

All dimensions are for reference only and are subject to change without notice.
NOTE: Body mounting 3/8"-16 thread

Ball Valves - 2-Way Series (1" Orifice)

Pressures to 10,000 psi (690 bar) 1.000" (25.40mm) Orifice

Connection	MAWP @ Room Temperature	Minimum Orifice Inches (mm)	Valve C _v
SM1500CX10 (Male)	10,000 psi (690 bar)	.938 (23.83)	30
1" SAE (Female)	10,000 psi (690 bar)	1.00 (25.40)	34
1" NPT (Female)	10,000 psi (690 bar)	1.00 (25.40)	34

MAWP: Maximum Allowable Working Pressure

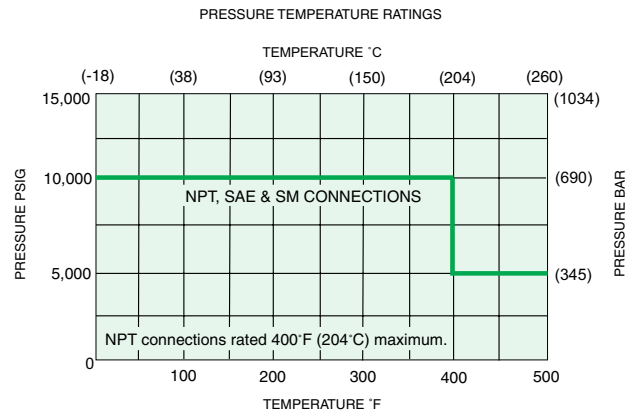
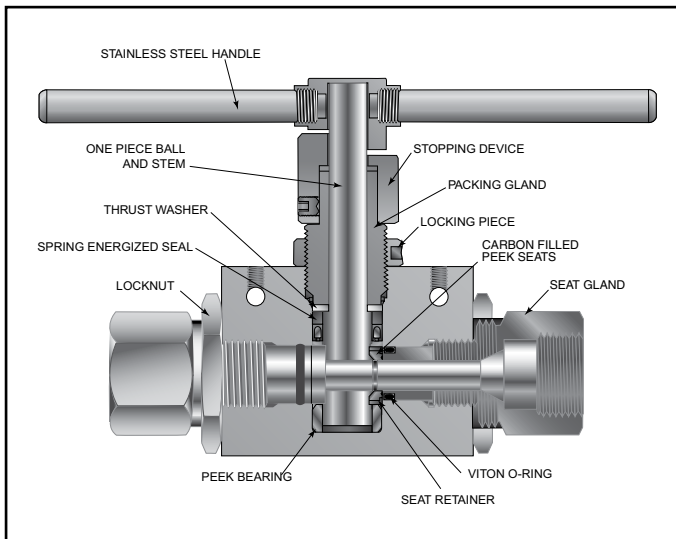
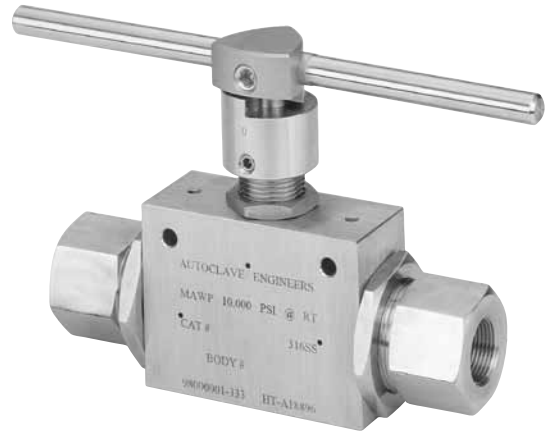

Pressure ratings are determined by the end connections chosen, see chart.

NOTE: Ball valves are not recommended for critical gas applications such as Hydrogen, Helium or other small molecular gases.

Ordering Procedure

For complete information on available end connections and material options, see next page. 2-way ball valves are furnished complete with tube or pipe connections.

Typical catalog number: **2B 16 S 10 MA24**

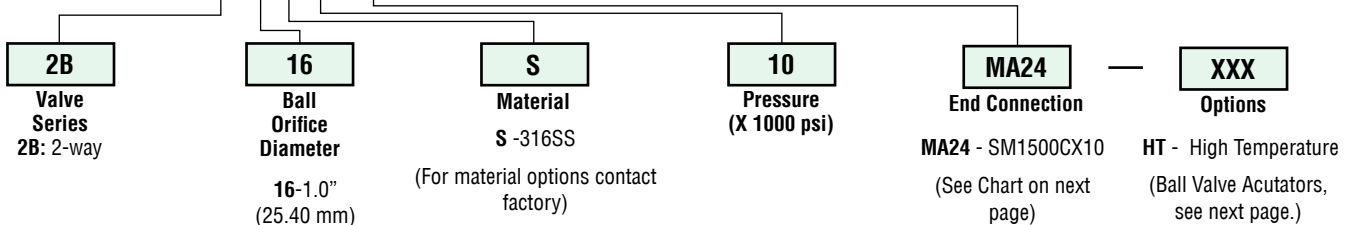

End Connection Options

Catalog Number	End Connection Number	Connection	MAWP @ Room Temperature	Seat Gland Hex Inches(mm)
2B16S10MA24	M24	SM1500CX10 (Male)	10,000 psi (690 bar)	1.88 (47.6) ^{*Square}
2B16S10S16	S16	1" SAE (Female)	10,000 psi (690 bar)	1.88 (47.6)
2B16S10P16	P16	1" NPT (Female)	10,000 psi (690 bar)	1.88 (47.6)

MAWP: Maximum Allowable Working Pressure

See ball valve option/details section for end connection details, material, and high temperature options.

Ball Valve Options

Valve Actuators

Consult Factory

Actuator Operating Temperature:

Pneumatic: 0°F to 175°F (-17°C to 79°C)

Electric: 0°F to 160°F (-17°C to 71°C)

Valve Maintenance

Repair Kits: add “R” to the front of valve catalog first 4 numbers for proper repair kit.
(Example: **R2B16S**)

Consult your Parker Autoclave Engineers representative for pricing on repair kits. Refer to the Operation and Maintenance manual for proper maintenance procedures.

Ball Valve Dimensions - inches (mm)

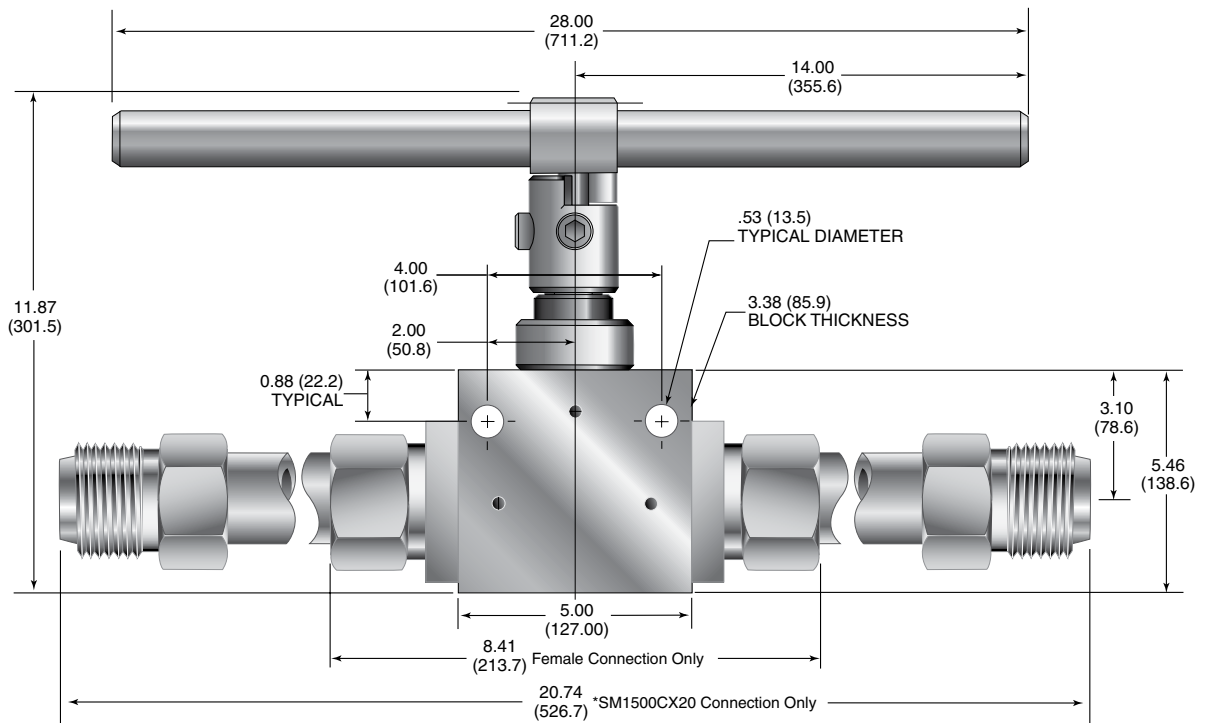

Ball Valve Panel Mounting Dimensions - inches (mm)

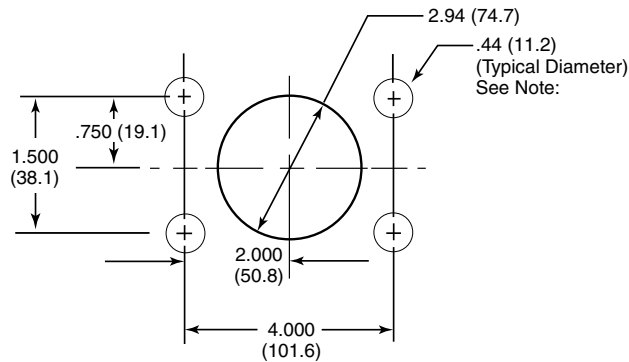

All dimensions are for reference only and are subject to change without notice.
NOTE: Body mounting 3/8"-16 thread

WARNING

FAILURE, IMPROPER SELECTION OR IMPROPER USE OF THE PRODUCTS AND/OR SYSTEMS DESCRIBED HEREIN OR RELATED ITEMS CAN CAUSE DEATH, PERSONAL INJURY AND PROPERTY DAMAGE.

This document and other information from Parker Hannifin Corporation, its subsidiaries and authorized distributors provide product and/or system options for further investigation by users having technical expertise. It is important that you analyze all aspects of your application and review the information concerning the product or system in the current product catalog. Due to the variety of operating conditions and applications for these products or systems, the user, through its own analysis and testing, is solely responsible for making the final selection of the products and systems and assuring that all performance, safety and warning requirements of the application are met. The products described herein, including without limitation, product features, specifications, designs, availability and pricing, are subject to change by Parker Hannifin Corporation and its subsidiaries at any time without notice.

Offer of Sale

The items described in this document are available for sale by Parker Hannifin Corporation, its subsidiaries or its authorized distributors. Any sale contract entered by Parker will be governed by the provisions stated in Parker's standard terms and conditions of sale (copy available upon request).



Instrumentation Products Division
Autoclave Engineers Operation
8325 Hessinger Drive
Erie, Pennsylvania 16509-4679 USA
PH: 814-860-5700 FAX: 814-860-5811
www.autoclave.com

Parker Hannifin Manufacturing Ltd.
Instrumentation Products Division, Europe
Industrial Estate Whitmill
Wexford, Republic of Ireland
PH: 353 53 914 1566
FAX: 353 53 914 1582

Caution! Do not mix or interchange parts or tubing with those of other manufacturers. Doing so is unsafe and will void warranty.

Caution! Parker Autoclave Engineers Valves, Fittings and Tools are not designed to work with common commercial instrument tubing and will only work with tubing built to Parker Autoclave Engineers AES Specifications. Failure to do so will void warranty.

ISO-9001 Certified